

SECTION 14-02 Generator, Integral Voltage Regulator — Internal Fan and Regulator Type

SUBJECT	PAGE	SUBJECT	PAGE
ADJUSTMENTS	14-02-7	REMOVAL AND INSTALLATION	
DESCRIPTION		Generator.....	14-02-2
Charging System	14-02-1	SPECIAL SERVICE TOOLS	14-02-7
Circuit Description.....	14-02-1	SPECIFICATIONS	14-02-7
Generator.....	14-02-1	VEHICLE APPLICATION	14-02-1
DISASSEMBLY AND ASSEMBLY			
Disassembly.....	14-02-4		

VEHICLE APPLICATION

Capri.

DESCRIPTION

Charging System

The electrical charging system is a negative ground system consisting of an integral generator (10300)/voltage regulator (IGR), charge indicator, storage battery and the necessary wiring and cables. Refer to the Electrical and Vacuum Troubleshooting manual for schematics and locations of components and wiring.

Generator

The integral generator / regulator (IGR) is belt-driven from the engine. Field current is supplied from the generator's internally mounted voltage regulator, to the rotating field of the generator through two brushes and two slip rings.

With the ignition key in the RUN position, voltage is applied through the charge indicator 'I' circuit to the voltage regulator. This turns on the regulator and the indicator. When the engine is started, the generator begins to generate alternating (AC) current which is converted to direct (DC) current by the rectifier assembly internal to the generator. This current is then supplied to the vehicles electrical system through the generator B+ connection located on the rear of the generator.

Once the generator begins generating current, a voltage signal is taken from the generator stator and fed back to the regulator warning circuit, turning off the charge indicator.

With the system functioning normally, the generator output current is determined by the voltage of the 'A' circuit (battery sense voltage). The 'A' circuit voltage is compared to a set voltage internal to the regulator, and the regulator controls the generator field current to maintain proper generator output. The set voltage will vary with temperature and is typically higher in the winter than in the summer, allowing for better battery recharge in the winter and reducing the chance of overcharging the battery in the summer.

Circuit Description

B+ Output

The generator output is supplied through the B+ output connection to the battery and electrical system.

'I' Circuit

The 'I' circuit, or ignition circuit, is used to turn on the voltage regulator. This circuit is powered up with the ignition key in the RUN position. This circuit is also used to turn the indicator on if there is a fault in the charging system operation or associated wiring circuits.

DESCRIPTION (Continued)**'A' Circuit**

The 'A' circuit, or battery sense circuit, is used to sense the battery voltage. This voltage is used by the regulator to determine the generator output. This circuit is connected back to the load distribution point and is a protected circuit.

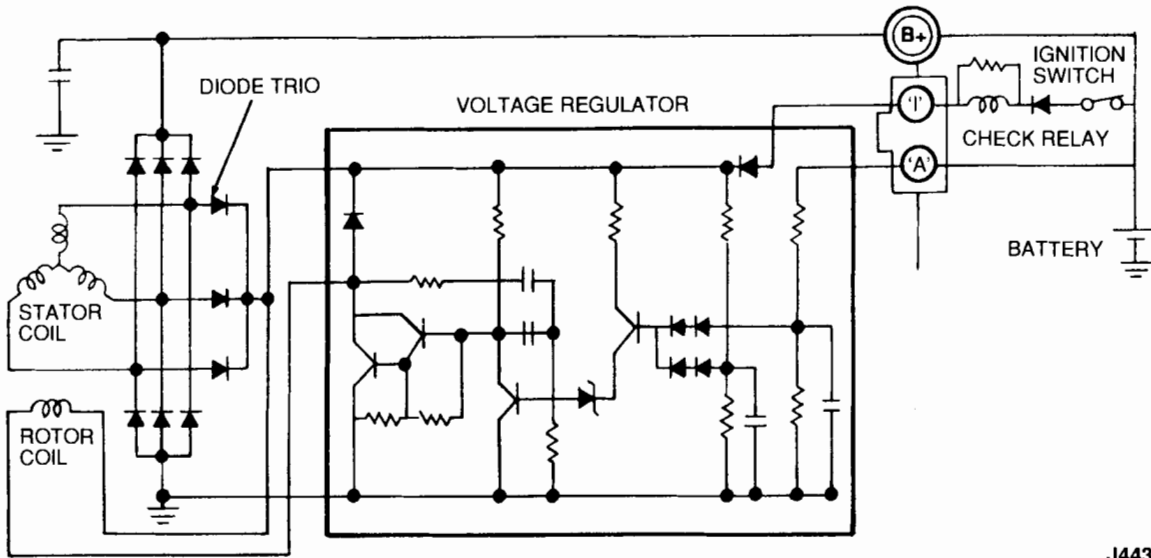

J4432-A

REMOVAL AND INSTALLATION**Generator****Removal and Installation**

1. Disconnect battery negative cable.
2. Remove nut and eyelet connector from 'B' terminal.
3. Disconnect electrical connector.
4. Remove adjustment bolt from top of generator.
5. Remove pivot bolt from bottom of generator and remove generator.
6. To install, reverse Removal procedure. Adjust bolt tension. Refer to Section 03-05.

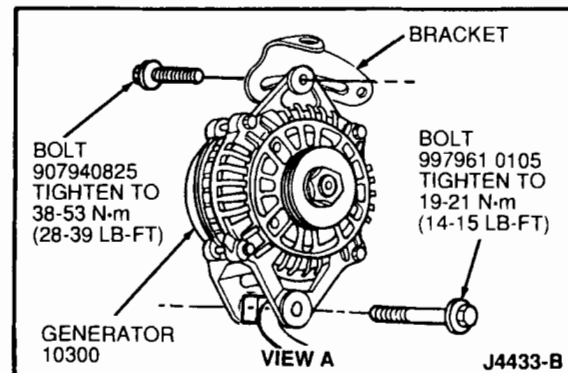
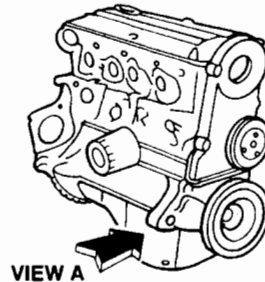

DISASSEMBLY AND ASSEMBLY

NOTE: All of the following Disassembly Steps may not be necessary to perform a particular test or service. Perform only those steps that apply. The following illustration is a disassembled view of the integral generator / regulator assembly.

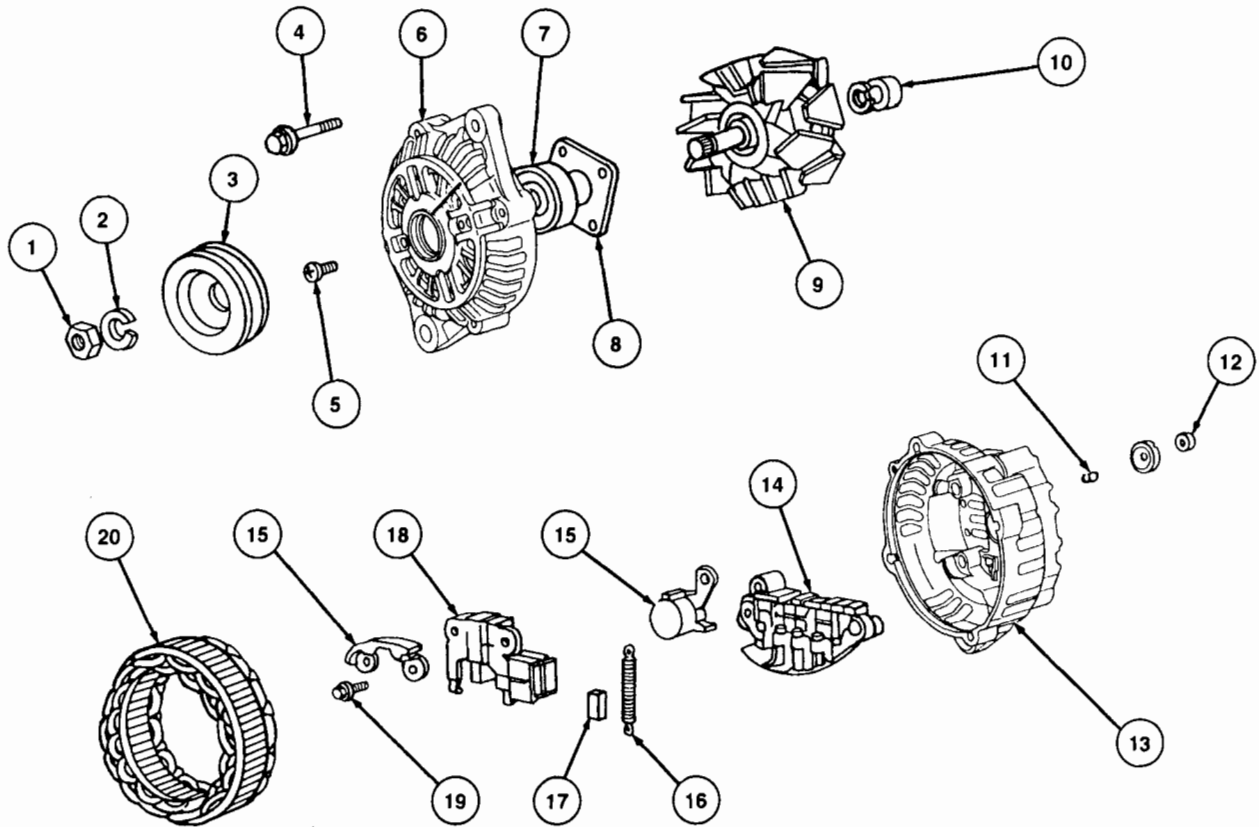

J4435-A

Item	Part Number	Description	Item	Part Number	Description
1	10B304	Nut	11	10B304	Plug
2	10B304	Washer	12	10K330	Nut and Terminal Insulator
3	10344	Pulley	13	10334	Rear Housing
4	10A396	Through Bolt (4 Req'd)	14	10304	Rectifier Assy
5	10A355	Screw (4 Req'd)	15	10316	Shield
6	10333	Front Housing	16	10347	Brush Spring (2 Req'd)
7	10334	Front Bearing	17	10347	Brush (2 Req'd)
8	10A355	Bearing Retainer	18	10316	Regulator
9	10335	Rotor	19	10316	Screw (2 Req'd)
10	10A304	Rear Bearing	20	10336	Stator

DISASSEMBLY AND ASSEMBLY (Continued)**Disassembly**

1. Place a soldering iron (200W class) on rear housing bearing recess for three or four minutes to heat to about 50-60°C (122-144°F).

NOTE: If the rear housing is not heated, the bearing may not be pulled out, because the rear bearing and rear housing fit together very tightly.

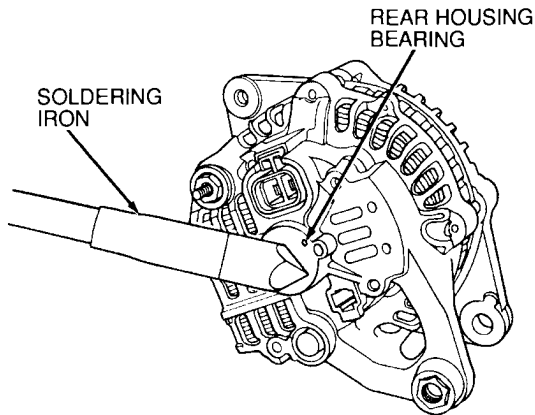

J4436-A

2. Remove four through-bolts, and insert a flat-tip screwdriver between the stator core and front housing and separate them.

NOTE: Be careful not to force screwdriver in too far, because stator may be scratched.

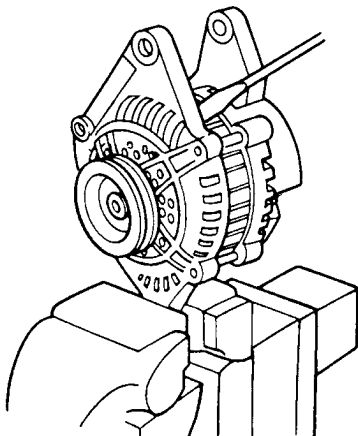

J4437-B

3. Remove locknut, pulley, rotor and front housing.

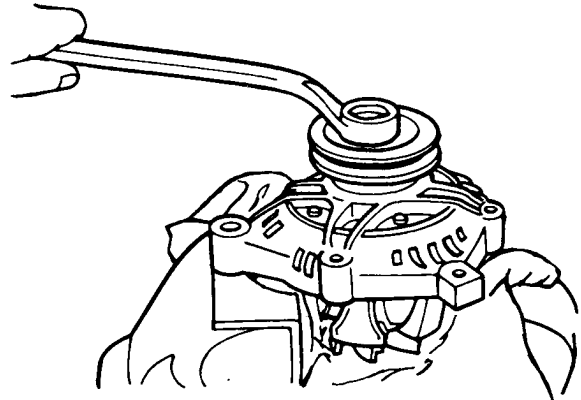

J3345-A

4. Remove the following rear bracket housing and stator parts:

- Nut on 'B' terminal
- Insulation bushing
- Rectifier retaining screws
- Brush holder retaining screw

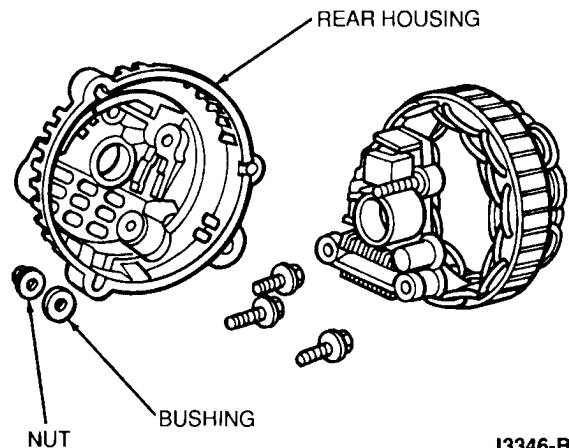

J3346-B

DISASSEMBLY AND ASSEMBLY (Continued)

- 5. Use a soldering iron to remove solder from rectifier and stator lead.
CAUTION: Disconnect quickly. Use the soldering iron no more than about five seconds, because the rectifier may become damaged if it is overheated.

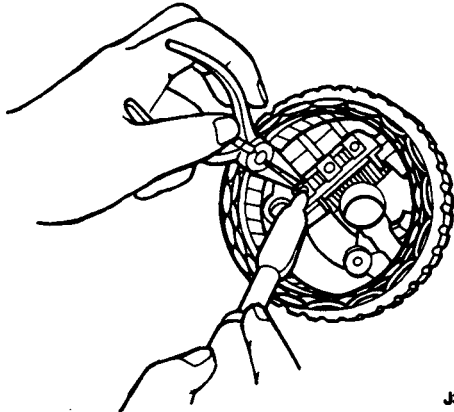

J3347-A

- 6. Use a soldering iron to remove regulator from rectifier.

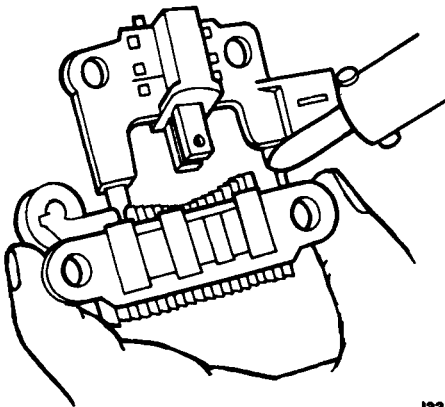

J3348-A

Brush Replacement

- 1. Replace brushes if they are worn at or near wear line as shown.

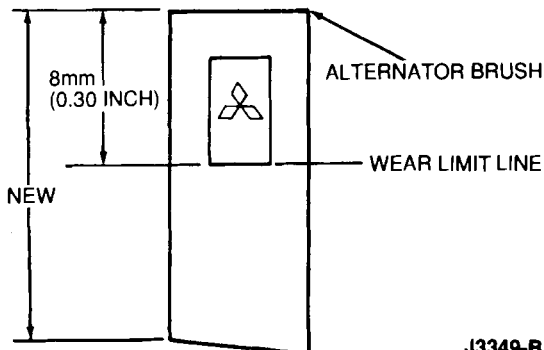

J3349-B

- 2. If it is necessary to replace brushes, remove solder from brush pigtails at points shown. Remove brushes.

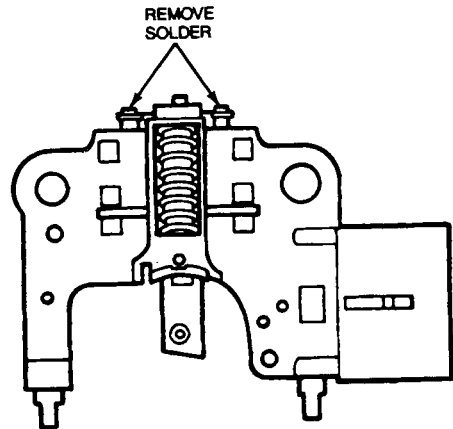

J3350-A

- 3. When soldering brush, solder pigtail so that wear limit line of brush projects 2 or 3mm (0.08-0.12 inch) out from end of brush holder.

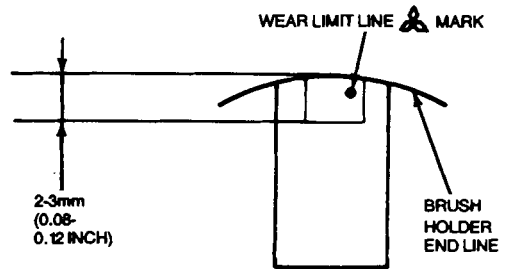

J3351-A

- 4. Brush springs may be checked by using a spring pressure gauge to push brush into brush holder until tip of brush projects 2mm (0.080 inch). Read force at this time. Replace spring if the force is less than 2.0N (200g or 7.1 oz). For a new brush the force should be 3 to 4.4N (310-450g or 10.9-15.9 oz).

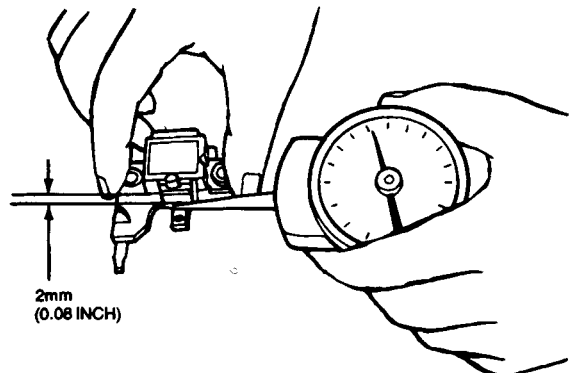

J3352-A

DISASSEMBLY AND ASSEMBLY (Continued)**Bearing Replacement**

1. Check front bearing for abnormal noise, looseness, binding or insufficient lubrication. Replace bearing if there is any concern.

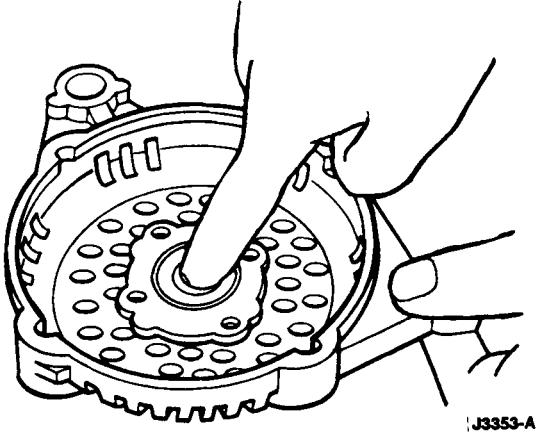

2. To replace generator front bearing, use a socket or driver which fits outer race of generator front bearing, and carefully press a new bearing into generator front housing using a press or vise.

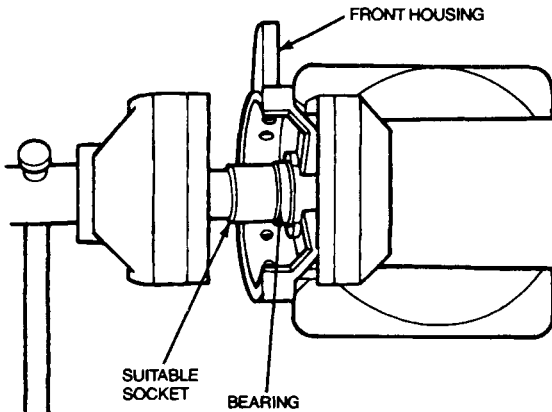

3. Check for rear bearing abnormal noise, looseness, binding, or insufficient lubrication. Replace bearing if there is any concern.
4. To replace the generator rear bearing, first remove the old bearing from the rotor using two-jaw Bearing Puller D80L-1002-L or equivalent as shown.

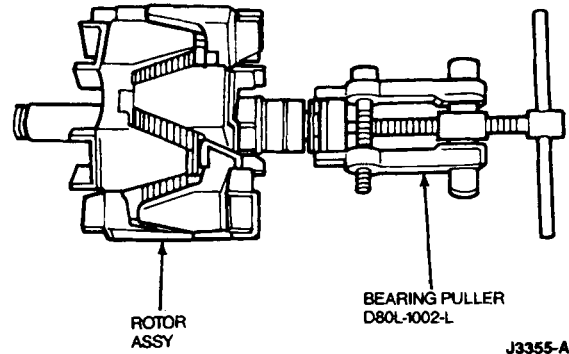

5. Check the bearings for abnormal noise, looseness or insufficient lubrication. Replace as necessary.

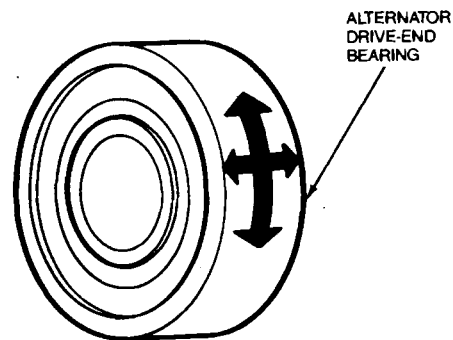
**Cleaning and Inspection**

CAUTION: When rebuilding an integral generator, use only high-temperature bearings. Use of standard parts will result in generator failure.

1. Wipe the stator, rotor and front bearing with a clean cloth. Do not clean these parts with solvent.
2. Rotate the front bearing on the drive end of the rotor shaft. Check for any scraping noise, looseness or roughness. Look for excessive lubricant leakage. If any of these conditions exist, replace the bearing.
3. Inspect the rotor shaft rear bearing surface for roughness or severe chatter marks. Replace the rotor assembly if the shaft is not smooth.
4. Place the rear bearing on the end of the rotor shaft and rotate the bearing. Make the same check for noise, looseness and roughness as was made for the front bearing. Inspect the rollers and cage for damage. Replace the rear bearing if these conditions exist or if the lubricant is lost or contaminated.
5. Check all wire leads on both the rotor and stator assemblies for loose or broken connections. Check the windings for burned insulation. Replace parts that show signs of burned insulation.

DISASSEMBLY AND ASSEMBLY (Continued)

6. Check the pulley and fan for excessive looseness on the rotor shaft and for cracks or other damage. Replace any pulley or fan that is loose, cracked or bent out of shape.
7. Check both the front and rear housings for cracks, particularly in the webbed areas at the mounting ear. Replace a damaged or cracked housing.
8. Replace the brushes if they are at or are worn shorter than the wear limit line, 8mm (0.30 inch).

Assembly

Assembly is in the reverse order of disassembly. There is no lubrication required.

1. Before assembly, push the brush into the brush holder and pass a wire (2 mm, 40-50mm (0.08 inch, 1.6-2.0 inch)) through the hole shown to secure the brush in position.

NOTE: Be sure to pull the wire out after the assembly is completed.

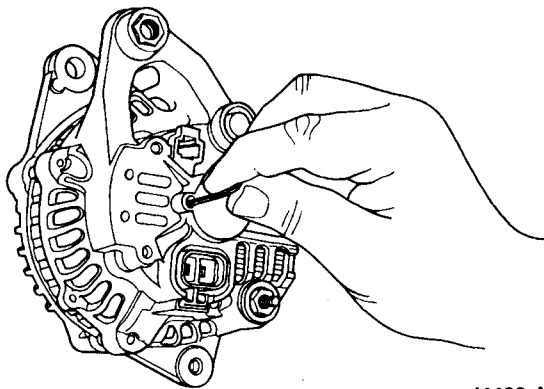

J4438-A

2. When the rear bearing is pressed into the rear bracket, heat the bracket before pressing it in.

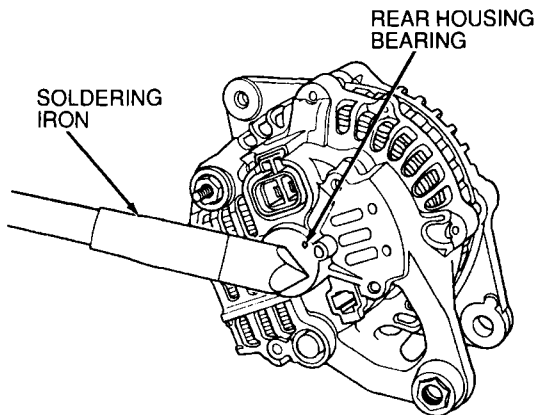

J4436-A

3. After assembly is completed, rotate the pulley manually and check that the rotor turns easily.
NOTE: Tighten pulley nut to 49-88 N·m (36-65 lb-ft).

ADJUSTMENTS

Refer to Section 03-05 for belt tension adjustment.

SPECIFICATIONS

TORQUE SPECIFICATIONS

Description	N·m	Lb·Ft
Ball Joint Clamp Bolt	43-54	32-40
Generator Fan Nut	49-88	36-65
Generator Through Bolts	3.8-5.5	33-49 Lb-In
Rectifier Retaining Screws	1.0-2.5	9-22 Lb-In
Voltage Regulator Retaining Screws	2.2-2.8	19-25 Lb-In
B+ Terminal to Rectifier Nut	8.0-11.0	70-97 Lb-In
B+ Terminal Adapter Nut	7.5-8.5	66-75 Lb-In
Wiring to B+ Terminal Nut	6.0-8.0	53-71 Lb-In
Radio Suppressor Screw	2.9-4.1	25-36 Lb-In
Bearing Plate Retainer Screws	2.1-3.0	18-27 Lb-In

SPECIAL SERVICE TOOLS

Tool Number	Description
D80L-1002-L	Bearing Puller