

# SECTION 03-07 Engine Ignition

SUBJECT	PAGE	SUBJECT	PAGE
DESCRIPTION .....	03-07-1	REMOVAL AND INSTALLATION (Cont'd.)	
DIAGNOSIS AND TESTING .....	03-07-2	Distributor Cap and Rotor .....	03-07-2
DISASSEMBLY AND ASSEMBLY		Ignition Coil .....	03-07-3
Distributor .....	03-07-4	Secondary Ignition Wires .....	03-07-2
Naturally Aspirated Vehicles .....	03-07-4	Spark Plugs .....	03-07-3
Turbocharged Vehicles .....	03-07-6	SPECIAL SERVICE TOOLS .....	03-07-8
OPERATION .....	03-07-1	SPECIFICATIONS .....	03-07-8
REMOVAL AND INSTALLATION		VEHICLE APPLICATION .....	03-07-1
Distributor .....	03-07-2		

## VEHICLE APPLICATION

Capri.

## DESCRIPTION

The ignition system consists of a distributor assembly, ignition coil, four spark plugs and high tension leads. The timing of the spark varies to suit engine speed and load conditions.

The distributor is mounted on the rear face of the cylinder head and is driven off the end of the camshaft. The ignition advance is mechanically controlled, according to engine speed, by weights inside the distributor body. Advance is also controlled, according to engine load, by vacuum control.

On naturally aspirated vehicles, ignition timing is modified by the powertrain control module (PCM) 12A650. Based on inputs from the barometric pressure sensor (BARO), at altitudes of 1000 m (3,280 ft) or higher, the PCM will signal the ignition module to advance ignition timing. Refer to Section 03-04A for information on the PCM.

The ignition coil is entirely moulded in resin, and is mounted to the air cleaner housing.

Motorcraft AGSP32C (naturally aspirated vehicles) or AGS32C (turbocharged vehicles) or equivalent spark plugs are used. A gasket is used to seal the spark plug against the cylinder head.

The high tension leads are of the carbon impregnated suppression type. All four plug leads vary in their overall length and are numbered for ease of identification. The number one cylinder is considered to be the front cylinder on the RH side of the vehicle.

On turbocharged vehicles, a knock sensor is mounted on the engine block; when knocking occurs a voltage is generated and a signal is sent to the knock control unit. The knock control unit determines if the signal from the knock sensor is caused by knocking or another source.

If it is a knocking signal, the spark is retarded according to the intensity of the knock, to a maximum of 15 degrees.

## OPERATION

Ignition timing must be variable due to the wide variation in engine speed and load under normal operating conditions. When accelerating or climbing hills, the engine load can be high and the amount of spark advance required is not necessarily as much as it would be on level ground at an equivalent engine speed. Ignition spark advance is achieved by two separate systems: mechanical advance weights and a vacuum diaphragm unit.

The mechanical advance mechanism consists of two weights pivoted so that they move outward from the distributor shaft as the engine speed increases. As the weights move outward, they turn the breaker plate in relation to the lower distributor shaft, thus advancing the ignition timing. Each weight is restrained by two springs of different tension, giving a progressive advance action. The amount the weights move outward is in direct proportion to the distributor shaft speed.

## DIAGNOSIS AND TESTING

For diagnosis and testing procedures, refer to Section 8B in the Powertrain Control/Emissions Diagnosis Manual<sup>1</sup>.

## REMOVAL AND INSTALLATION

### Distributor

#### Removal

1. Disconnect negative battery cable.
2. Disconnect vacuum hose from vacuum control unit.
3. Disconnect electrical connectors.
4. Disconnect coil wire from distributor cap.
5. Remove two retaining screws from distributor cap, and position out of the way.
6. Scribe distributor housing and cylinder head so that distributor may be installed in its original position. Note location of rotor.  
NOTE: Distributor can only be installed one way.
7. Remove two distributor hold-down bolts and remove distributor.
8. Inspect O-ring, replace if damaged or worn.

#### Installation

NOTE: If the crankshaft is turned while the distributor is removed, the rotor position noted during removal can no longer be used to correctly time the distributor to the camshaft. The drive tang of the distributor is off-set so as to allow only one installation position. Insert distributor and rotate rotor until drive tang falls into slot of camshaft.

1. Set rotor to position noted during removal. Lubricate O-ring seal with engine oil.
2. Install distributor on rear of cylinder head and align scribe marks.
3. Install two distributor hold-down bolts.
4. Install distributor cap and tighten two retaining screws.
5. Connect coil wire to distributor cap.
6. Connect electrical connectors.
7. Connect vacuum hoses to vacuum control unit.
8. Connect negative battery cable.
9. Start engine, check and adjust ignition timing as necessary. Refer to Powertrain Control/Emissions Diagnosis Manual<sup>1</sup>.

### Distributor Cap and Rotor

#### Removal

1. Mark spark plug wires to ensure proper sequence during installation.
2. Remove spark plug wires from distributor cap.
3. Remove two retaining screws and remove distributor cap.
4. Remove rotor from distributor upper shaft.

#### Cleaning and Inspection

- Wash the distributor cap with soap and water and dry with compressed air.
- Inspect the cap for cracks, broken carbon button, carbon tracking, dirt or corrosion on the terminals. Replace the cap if it is damaged.
- Wipe rotor with a clean soft cloth.
- Inspect rotor and replace if cracks, carbon tracking or burns are found.

#### Installation

1. Position rotor onto upper shaft and push in securely. Make sure flat on upper shaft is aligned with flat on rotor.
2. Position cap onto distributor and ensure locating tabs are aligned.
3. Tighten two retaining screws on distributor cap.
4. Install spark plug wires in proper locations on cap noted during removal.

### Secondary Ignition Wires

#### Removal

1. Mark wires in relation to distributor cap terminals and cylinder number to ensure proper sequence during installation.
2. Disconnect wires from distributor cap and coil, by grasping boot by hand and remove with a twisting and pulling motion. Do not pull on wire.
3. If necessary, remove throttle body inlet tube.

<sup>1</sup> Can be purchased as a separate item.

**REMOVAL AND INSTALLATION (Continued)**

4. Use Spark Plug Wire Removal Tool T74P-6666-A or equivalent. Grasp and twist boot back and forth on spark plug insulator to free boot from spark plug. Use special tool to pull boot from plug. Do not pull on wire directly, or it may separate from connector inside boot.

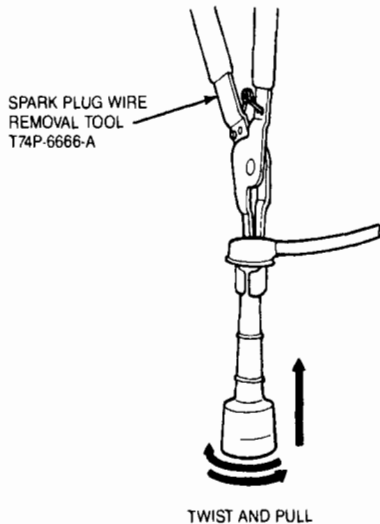

B4447-A

5. Note routing of wires and remove from braces.

**Installation**

1. Install correct wires onto spark plugs as noted during removal.
2. Install correct wire ends into distributor cap and coil as noted during removal.
3. Route wires as noted during removal and secure in braces.
4. If removed, install throttle body inlet tube.

**Spark Plugs****Removal**

1. Remove spark plug leads from spark plugs as outlined.
2. Use compressed air to blow away any dirt from around spark plugs to prevent it from entering through spark plug hole.

**Installation**

1. Gap spark plugs to 1.0-1.1mm.

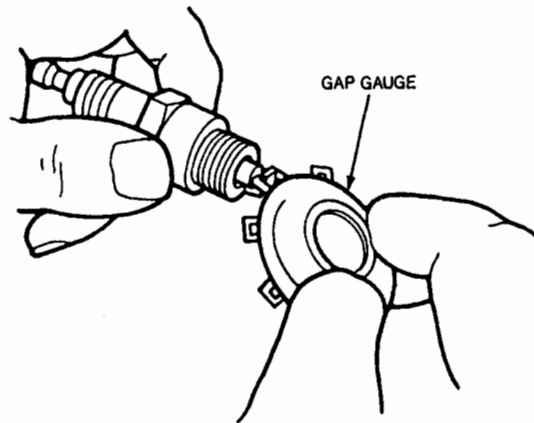

B4448-A

2. Install spark plugs into cylinder head and tighten to 14-23 N·m (11-16 lb-ft).
3. Install spark plug leads to proper spark plug as noted during removal.

**Ignition Coil****Removal**

1. Disconnect negative battery cable.
2. Disconnect primary wire connector from coil.
3. Disconnect secondary wire from coil.
4. Remove two bolts retaining coil.
5. Remove ignition coil from air cleaner housing.

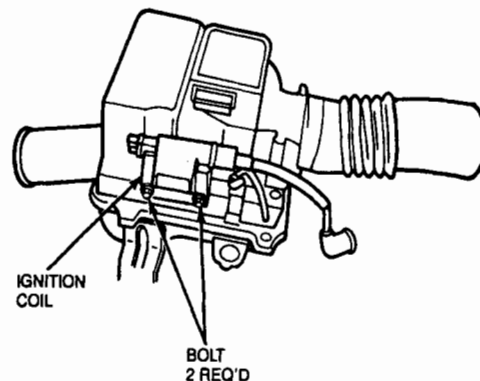

B4449-A

**Installation**

1. Position ignition coil onto air cleaner housing.
2. Install two bolts retaining coil.
3. Connect secondary wire to coil tower.

**REMOVAL AND INSTALLATION (Continued)**

4. Connect primary wire connector to coil.
5. Connect negative battery cable.

**DISASSEMBLY AND ASSEMBLY****Distributor****Naturally Aspirated Vehicles****Disassembly**

1. Loosen two screws retaining distributor cap and remove distributor cap.
2. Remove pick-up unit and radio noise suppressor.
3. Note location of connectors and disconnect connectors from igniter.
4. Remove two igniter retaining screws.
5. Using 2-Jaw Puller D80L-1002-L or equivalent, pull armature and pin from upper shaft.

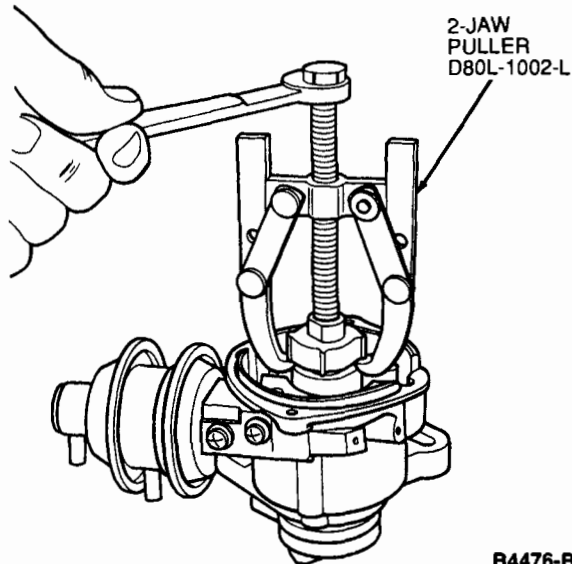

6. Remove igniter assembly.
7. Remove two retaining screws from mounting plate and remove mounting plate.
8. Remove retaining clip and two screws retaining vacuum control unit and remove control unit.
9. Remove two screws retaining breaker plate assembly.
10. Remove breaker plate assembly.
11. Remove snap ring retaining advance plate and remove advance plate and spacer.
12. Mark the upper shaft and an advance weight pin with paint.  
**NOTE:** Marking location of upper shaft is necessary to ensure that upper shaft is installed properly during assembly.
13. Remove retaining screw from inside upper shaft and remove upper shaft.
14. Mark position of lower shaft to drive collar with paint and drive out roll pin with a suitable punch.
15. Remove two retaining screws from bearing plate and remove lower shaft.
16. Remove retaining clips and springs from advance weights and remove advance weights.
17. If necessary, press off bearing from lower shaft.

**DISASSEMBLY AND ASSEMBLY (Continued)**

18. If necessary, remove oil seal from housing.

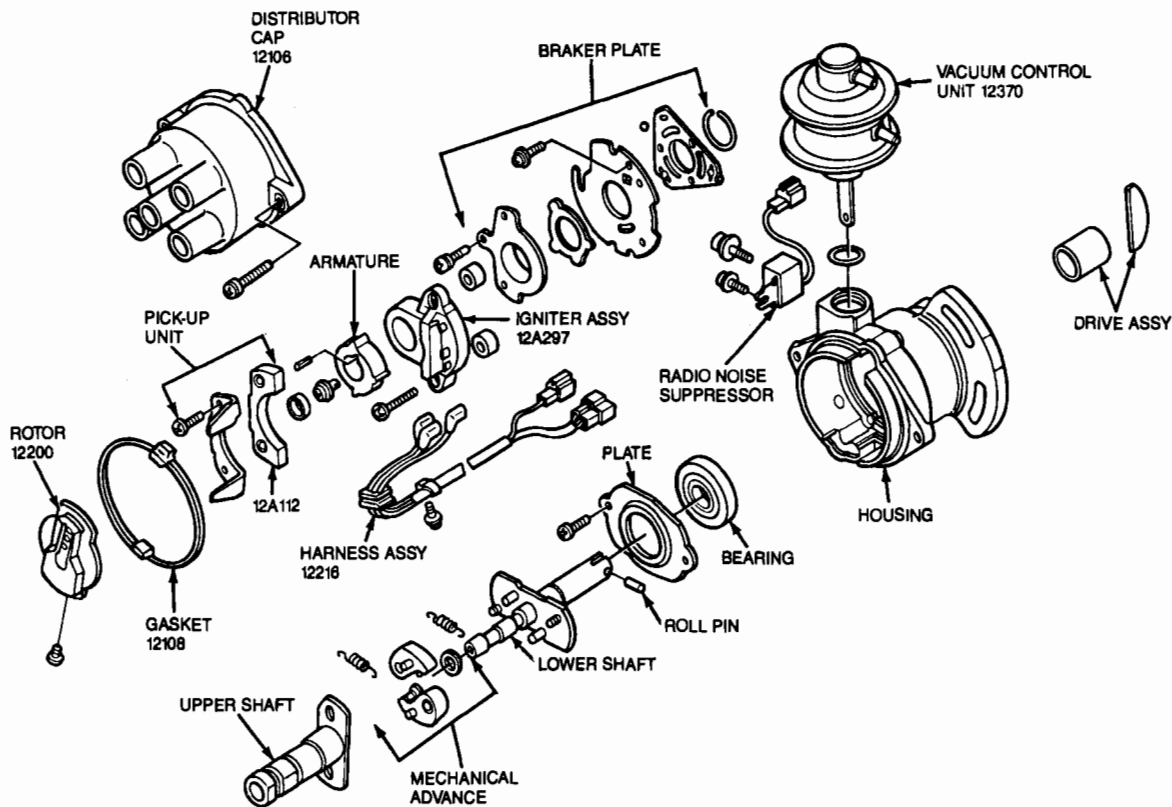

B4450-A

**Cleaning and Inspection**

- Wipe all parts with a clean cloth.
- Inspect O-rings and replace if damaged or worn.
- Inspect distributor base for damage.
- Inspect lower shaft for looseness or binding.
- Lubricate all pivoting and sliding surfaces with Motor Oil ESF-M2C70-A or equivalent.
- Apply a thin, even film of Silicone Dielectric Compound D7AZ-19A331-A or equivalent to the igniter mounting face.

**Assembly**

1. If removed, install oil seal in housing.
2. If removed, press bearing on lower shaft.
3. Install advance weights, retaining clips and springs.
4. Install lower shaft into housing and install two retaining screws into bearing plate.
5. Install drive collar onto lower shaft, align paint marks and drive in roll pin.  
NOTE: Roll pin must be driven in until flush with collar outer surface.
6. Install upper shaft and align paint marks.
7. Install retaining screw in upper shaft.
8. Install spacer, advance plate and snap ring.
9. Install breaker plate and secure with two retaining screws.
10. Position vacuum control unit. Make sure actuating arm is installed on stud of breaker plate.
11. Install two screws retaining vacuum control unit and install actuating arm retaining clip.
12. Position mounting plate and secure with two retaining screws.
13. Position igniter assembly and secure with two retaining screws.

**DISASSEMBLY AND ASSEMBLY (Continued)**

14. Using a socket and the palm of your hand, press armature and pin onto upper shaft until it bottoms against shoulder of upper shaft.

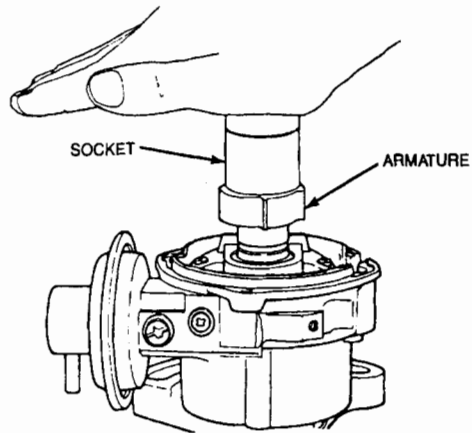

B4443-A

15. Connect igniter leads in positions noted during Disassembly.  
 16. Install pick-up unit and radio noise suppressor.  
 17. Install dust cover, gasket and distributor rotor.  
 18. Install distributor cap and secure with two retaining screws.

**Turbocharged Vehicles****Disassembly**

1. Loosen two screws retaining distributor cap and remove distributor cap.
2. Remove distributor rotor.
3. Remove dust cover.
4. Remove screws retaining signal rotor and remove signal rotor.
5. Disconnect connector on pick-up assembly.
6. Remove two screws retaining pick-up assembly and remove pick-up assembly.
7. Remove two screws retaining mounting plate and remove mounting plate.

8. Remove snap ring retaining armature and pin.
9. Pull armature and pin from upper shaft using 2-Jaw Puller D80L-1002-L or equivalent.

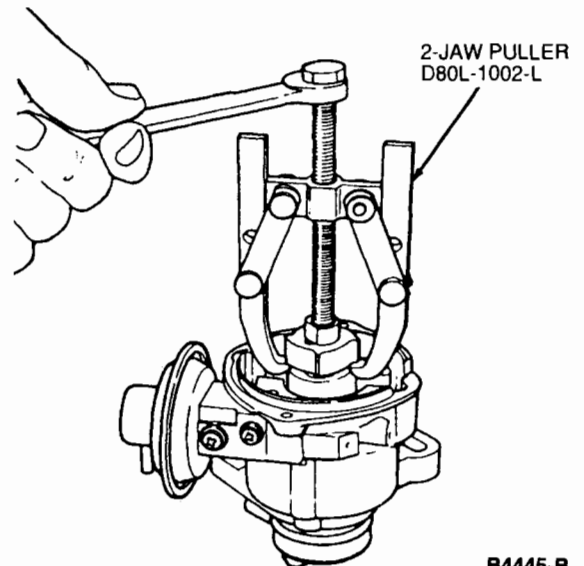

B4445-B

10. Disconnect connectors on igniter, remove two retaining screws and remove igniter.
11. Remove two screws retaining spacer plate and remove spacer plate.
12. If necessary, remove screw retaining harness assembly to housing and remove harness.
13. Remove retaining clip from actuating arm and two retaining screws from vacuum control unit.
14. Remove vacuum control unit.
15. Remove breaker plate.
16. Remove snap ring and remove advance plate.
17. Remove upper shaft.
18. Remove two advance springs and remove advance weights.
19. Drive roll pin, retaining drive assembly through lower shaft and remove drive assembly.
20. Remove lower shaft.

**DISASSEMBLY AND ASSEMBLY (Continued)**

21. If necessary, remove oil seal.

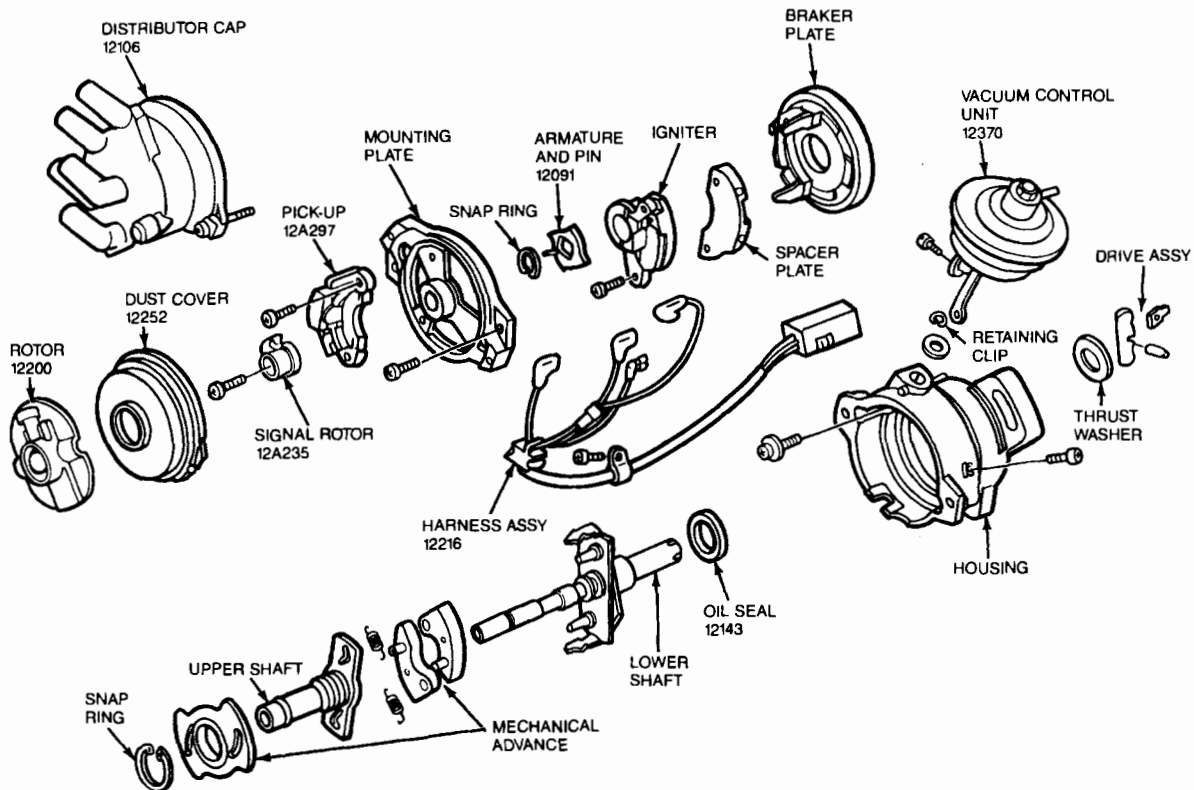

B4444-A

**Cleaning and Inspection**

- Wipe all parts with a clean cloth.
- Inspect O-rings and replace if damaged or worn.
- Inspect distributor base for damage.
- Inspect lower shaft for looseness or binding.
- Lubricate all pivoting and sliding surfaces Motor Oil with ESF-M2C70-A or equivalent.
- Apply a thin, even film of Silicone Dielectric Compound D7AZ-19A331-A, or equivalent to the igniter mounting face.

**Assembly**

1. If removed, install oil seal.
2. Install lower shaft into housing.
3. Position drive assembly onto lower shaft, align holes and install roll pin.
4. Install advance weights and springs.
5. Install upper shaft.
6. Install advance plate and snap ring.
7. Install breaker plate.
8. Position vacuum control unit. Make sure actuating arm is installed on stud of breaker plate.
9. Install two screws retaining vacuum control unit and install actuating arm retaining clip.
10. If removed, position harness to housing and secure with retaining screws.
11. Position spacer plate and install two retaining screws.
12. Position igniter, install two retaining screws and connect wiring connectors.

**DISASSEMBLY AND ASSEMBLY (Continued)**

13. Using a socket and the palm of your hand, press armature and pin onto upper shaft until it bottoms against shoulder of upper shaft.

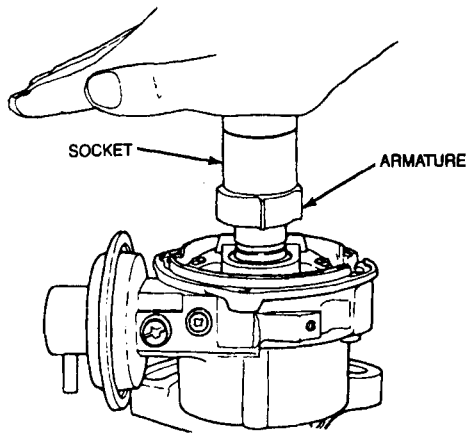

B4443-A

14. Install snap ring retaining armature and pin.  
 15. Install mounting plate with two retaining screws.  
 16. Install pick-up assembly with two retaining screws.  
 17. Connect wiring connector on pick-up assembly.  
 18. Position signal rotor onto upper shaft and secure with retaining screw.

19. Install dust cover.  
 20. Install rotor.  
 21. Install distributor cap and tighten two retaining screws

**SPECIFICATIONS****GENERAL SPECIFICATIONS**

Description	Specification
Spark Plug Type	AGSP-32C
Plug Gap	1.0-1.1mm (.039-.043 inch)
Firing Order	1-3-4-2
Ignition Timing	
— Naturally Aspirated	2° BTDC
— Turbocharged	12° BTDC

**TORQUE SPECIFICATIONS**

Description	N·m	Lb·Ft
Spark Plugs	14-23	11-16

**SPECIAL SERVICE TOOLS**

Tool Number	Description
D80L-1002-L	2-Jaw Puller
T74P-6666-A	Spark Plug Wire Remover