

# SECTION 03-01 Engine, 1.6L

SUBJECT	PAGE	SUBJECT	PAGE
DESCRIPTION .....	03-01-1	REMOVAL AND INSTALLATION (Cont'd.)	
DISASSEMBLY AND ASSEMBLY		Valve Stem Seals .....	03-01-18
Assembly .....	03-01-32	Water Pump .....	03-01-16
Flywheel, Pilot Bearing .....	03-01-33	SERVICE PROCEDURES	
Oil Pump .....	03-01-32	Camshaft .....	03-01-43
Cylinder Head .....	03-01-29	Connecting Rod .....	03-01-37
Engine .....	03-01-22	Crankshaft .....	03-01-37
Subassemblies .....	03-01-31	Crankshaft and Connecting Rod	
Piston and Connecting Rod .....	03-01-31	Bearings .....	03-01-38
REMOVAL AND INSTALLATION		Crankshaft End Play .....	03-01-39
Camshaft .....	03-01-13	Crankshaft Oil Clearance .....	03-01-39
Camshaft Seal .....	03-01-16	Cylinder Block .....	03-01-33
Core Plugs .....	03-01-22	Cylinder Block Flatness .....	03-01-34
Crankshaft Oil Seal, Front .....	03-01-21	Cylinder Bores .....	03-01-35
Crankshaft Oil Seal, Rear .....	03-01-21	Cylinder Head .....	03-01-40
Crankshaft, Main Bearings and Connecting		Cylinder Head Flatness .....	03-01-41
Rod Bearings .....	03-01-15	Valve and Valve Guide .....	03-01-41
Cylinder Head .....	03-01-9	Valve Seat .....	03-01-42
Engine Assembly .....	03-01-2	Valve Spring .....	03-01-43
Exhaust Manifold .....	03-01-17	Oil Jet .....	03-01-40
Intake Manifold .....	03-01-16	Oil Pump .....	03-01-39
Oil Pan .....	03-01-18	Pistons, Piston Rings and Piston Pins .....	03-01-36
Oil Pump .....	03-01-20	Service Limit Specifications .....	03-01-33
Piston and Connecting Rod Assembly .....	03-01-20	SPECIAL SERVICE TOOLS .....	03-01-48
Thermostat .....	03-01-18	SPECIFICATIONS .....	03-01-46
Throttle Body .....	03-01-18	VEHICLE APPLICATION .....	03-01-1
Timing Belt .....	03-01-11		

## VEHICLE APPLICATION

Capri.

## DESCRIPTION

The 1.6L naturally aspirated and 1.6L Turbocharged / Intercooled engines are double overhead cam (DOHC), four valves per cylinder, four cylinder engines. The cylinder head is aluminum and incorporates directly operating bucket-type hydraulic lash adjusters (HLA).

The camshafts are driven by a single, toothed belt. One camshaft operates the intake valves, one operates the exhaust valves. The timing belt is automatically adjusted by a spring tensioned pulley.

The intake manifold is aluminum and has a coolant passage for better driveability during cold weather operation.

The ignition system is an electronic, high output type using a vacuum advance distributor. The distributor is driven directly off the intake camshaft.

The multiport fuel injection (MFI) system is electronic. A volume air flow (VAF) (12B529) meter senses intake air flow rate and temperature. An electric fuel pump, mounted inside the fuel tank delivers fuel at a constant rate to the fuel pressure regulator. The pressure regulator returns excess fuel to the fuel tank while keeping the four fuel injectors supplied with sufficient fuel through the fuel rail assembly.

Injector "on time" is controlled by the powertrain control module (PCM) (12A650), based on information supplied by the VAF, engine coolant temperature (ECT) (12A648) sensor, and throttle position (TP) (9P989) sensor.

**DESCRIPTION (Continued)**

The lubrication system is a high pressure-type supplied by the oil pump. The oil pump is driven directly by the crankshaft. On turbocharged engines, oil spray nozzles are mounted in the cylinder block. The nozzles spray oil up into the inside of the pistons to aid in cooling and prevent detonation.

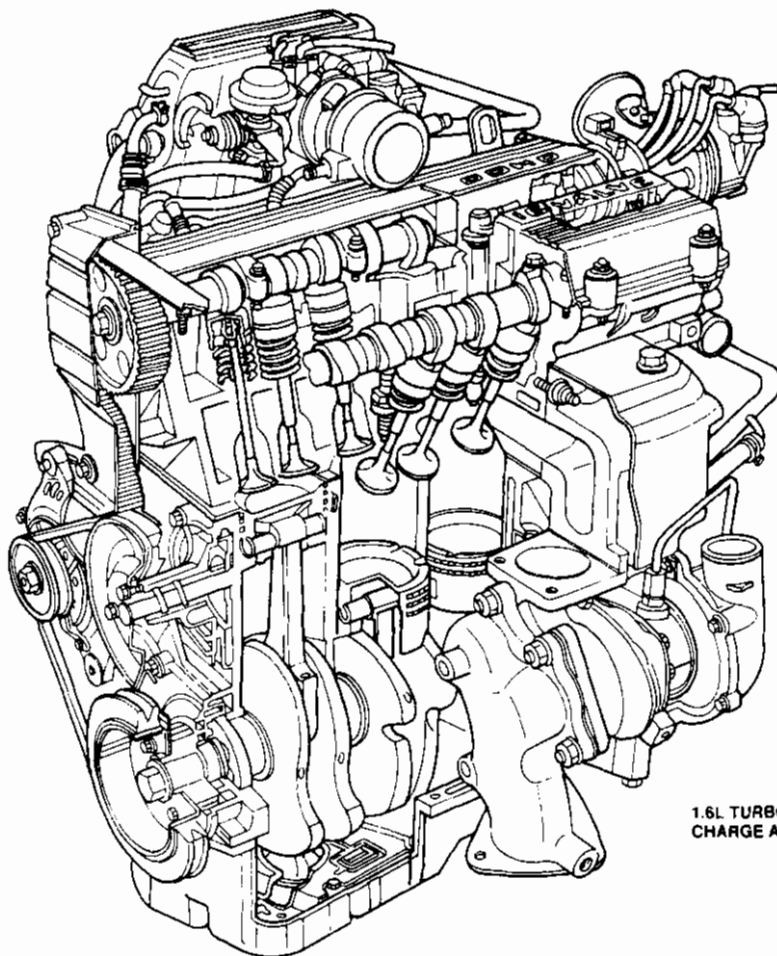

1.6L TURBOCHARGED/  
CHARGE AIR COOLED ENGINE

A13501-B

**REMOVAL AND INSTALLATION****Engine Assembly****Removal**

1. Relieve fuel pressure by disconnecting electrical connector at fuel pump-sending unit assembly located under rear seat cushion. If necessary, refer to Section 01-10 for rear seat cushion removal.

2. Start the engine and allow it to run until it stalls. The fuel pressure is now relieved.
3. Discharge the air conditioning system, if equipped. Refer to Section 12-00.

## REMOVAL AND INSTALLATION (Continued)

4. Disconnect and remove battery, battery tray and battery tray support bracket.

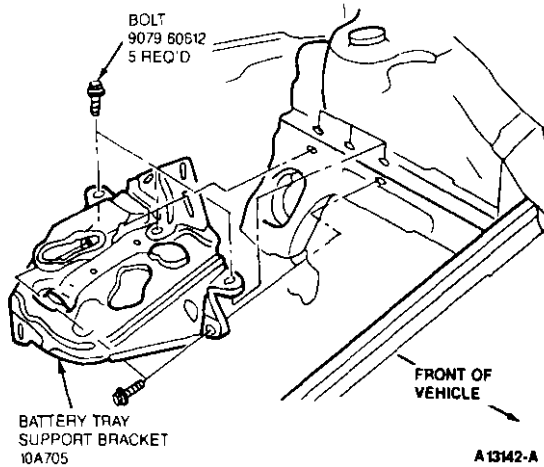

5. Release wiring harness retaining straps from battery support tray.
6. Disconnect windshield washer supply hose between washer fluid reservoir and hood.
7. Mark hood hinge locations and remove hood.
8. Disconnect intake air tube and wiring to ignition coil and volume air flow meter.
9. Remove air cleaner / volume air flow meter assembly. Refer to Section 03-12.
10. Remove air cleaner assembly support brackets. Refer to Section 03-12.
11. Disconnect charge air cooler hoses from turbocharger, if equipped.
12. Drain engine coolant and remove radiator. Refer to Section 03-03.
13. Disconnect accelerator cable and remove retaining bracket from cylinder head cover. Position cable aside. Refer to Section 10-02.

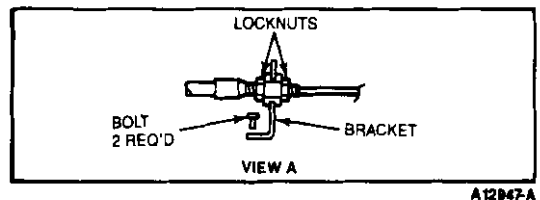
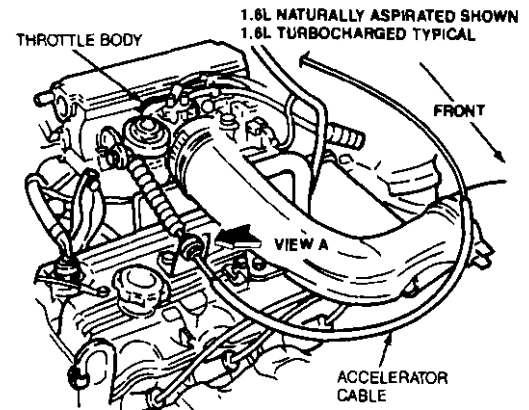

14. Disconnect speedometer cable at cable connection located under hood. Refer to Section 13-01.
15. Disconnect and plug fuel lines at fuel filter and pressure regulator.
16. Disconnect power brake booster manifold vacuum hose from manifold.
17. Disconnect heater hoses at heater core tubes.

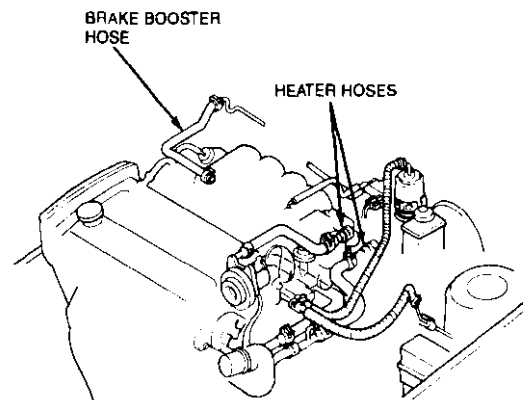

A1348-A

## REMOVAL AND INSTALLATION (Continued)

18. Label and remove vacuum hoses located at throttle body (TB) (9E926).

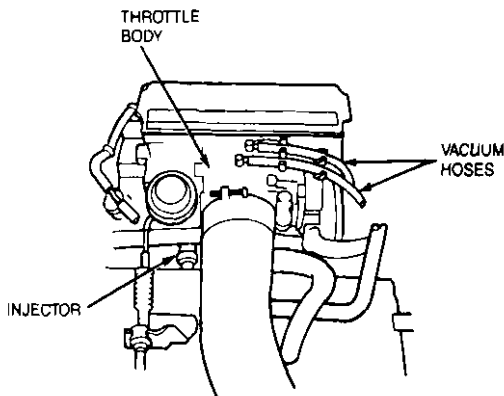

1.6L TURBOCHARGED SHOWN  
1.6L NATURALLY ASPIRATED TYPICAL

A12927-A

19. For manual transaxle turbocharged vehicles, disconnect clutch cable and remove support bracket and cable from transmission. Refer to Section 07-03B. On naturally aspirated vehicles, disconnect clutch slave cylinder hydraulic line. Refer to Section 07-03A.

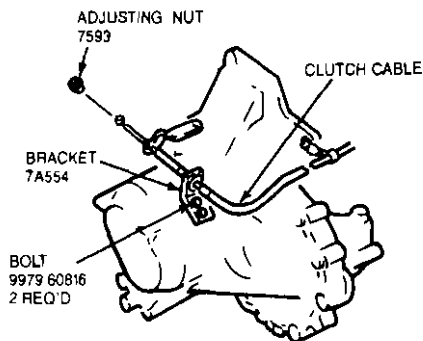

A12948-A

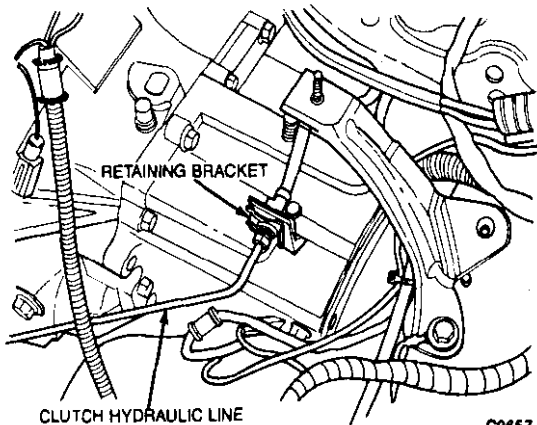

C0657-A

20. For automatic transaxle, remove transaxle cooler lines.

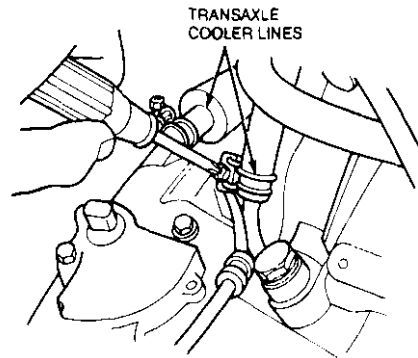

A1343-A

21. Disconnect starter wiring at starter. Remove harness from locating strap on bracket.
22. Disconnect generator (GEN) (10300) wiring.
23. Disconnect wiring from engine coolant temperature (ECT) (12A648) sensors located on rear of engine block.
24. Remove ground connection at bracket on thermostat cover.
25. Disconnect oxygen sensor (O2S) (9F472) wire, main wiring harness connector, throttle position (TP) sensor connector (turbocharged vehicles only), knock sensor (KS) (12A699) connector, distributor wiring and transaxle wiring.
26. Disconnect ground wire and strap at front of engine. Re-install lifting eye.
27. Remove engine oil dipstick and dipstick retaining clip.
28. Remove power steering pump from bracket. Refer to Section 11-02.
29. Remove power steering pump mounting bracket.
30. Position power steering pump aside (hoses attached).
31. Remove upper air conditioning compressor retaining bolts, if equipped.
32. Raise vehicle on hoist. Refer to Section 00-02.
33. Drain engine oil.
34. On vehicles with air conditioning, remove lower air conditioning compressor mounting bolts and position compressor out of the way.
- CAUTION: Do not let compressor hang by the hoses. Tie up with mechanic's wire.**
35. Remove front wheel and tire assemblies. Refer to Section 04-04.
36. Remove front ball joint to steering knuckle retaining bolts. Refer to Section 11-02.
37. Remove splash guards.

**REMOVAL AND INSTALLATION (Continued)**

- 38. Drain transmission oil and remove halfshafts from differential. Refer to Section 05-04.
- 39. Remove front exhaust pipe bracket located on lower side of engine.
- 40. Disconnect front exhaust pipe from exhaust manifold, or turbocharger, if so equipped.
- 41. Remove frame support bar-to-engine support bolt. Loosen right control arm bolt and pivot support bar downward.
- 42. Disengage rubber exhaust hangers located directly behind catalytic converter.
- 43. Allow exhaust system to hang down six inches and support with mechanic's wire.
- 44. Unbolt transaxle shift linkage and stabilizer bar at transaxle.

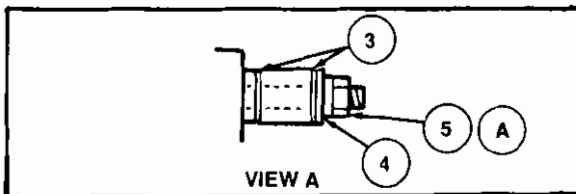
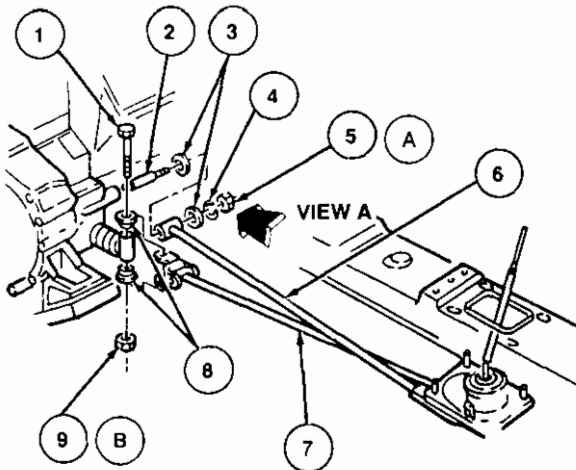

A12946-B

Item	Part Number	Description
1	7353	Bolt (1 Req'd)
2	7378	Stud
3	9995-21030	Flat Washers
4	9997-11000	Spring Washer
5A	9992-11000	Nut (1 Req'd)
6	7L257	Shifter Stabilizer
7	7B140	Shift Linkage
8	7335	Bushings
9B	9990-60800	Nut
A		Tighten to 31-46 N-m (23-34 Lb-Ft)
B		Tighten to 16-22 N-m (12-16 Lb-Ft)

- 45. Remove nuts from front and rear engine mounts.

## REMOVAL AND INSTALLATION (Continued)

46. Lower vehicle.

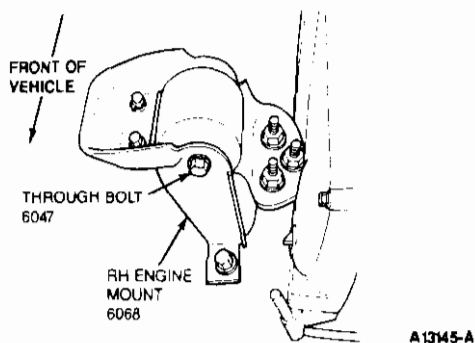
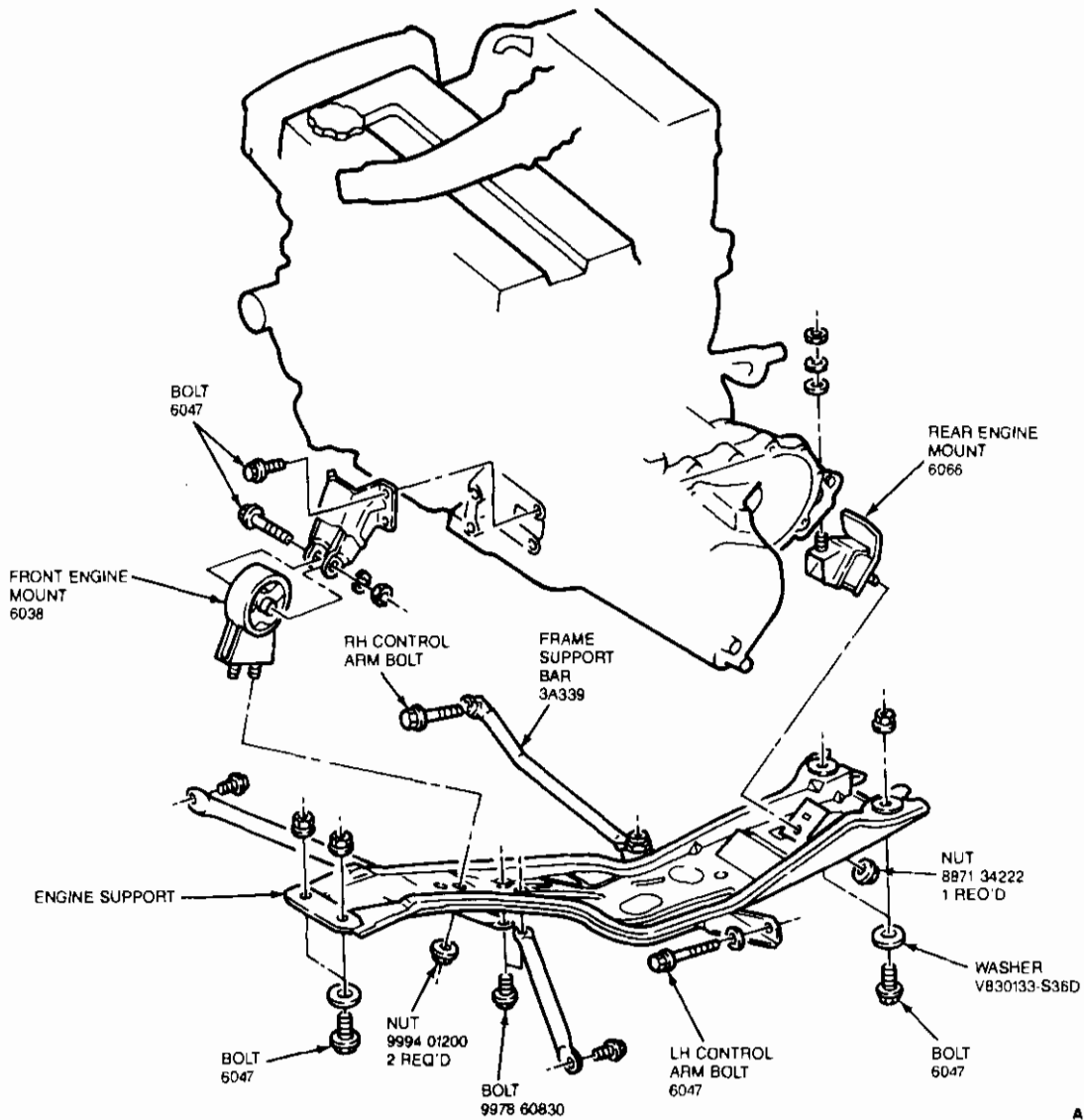

47. Position Rotunda Portable Crane 077-00043 or equivalent. Attach chains onto lift eyes located on sides of cylinder head.
48. Support engine with crane and remove RH engine mount through-bolt.
49. Raise engine off of mounts and slightly pivot engine/transaxle assembly.
50. Disconnect oil pressure sender and route starter/alternator wiring harness from engine.
51. Carefully lift engine/transaxle assembly, turn assembly while raising to clear the brake master cylinder, shift linkage universal joint, radiator support and air conditioning lines, if so equipped.

**REMOVAL AND INSTALLATION (Continued)**

52. Remove intake manifold support bracket.
53. Remove gusset plate(s), if equipped.
54. Remove starter.
55. Remove transaxle to engine retaining bolts. Identify bolts to ensure they are installed in their correct locations for installation.
56. Separate transaxle from engine.
57. On manual transaxles, remove pressure plate, clutch disc, and flywheel.
58. On automatic transaxles, remove flywheel.
59. Install engine on engine stand.

**Installation**

1. Remove engine from stand.
2. Install end plate. Tighten retaining screw to 8-11 N·m (7 1-97 lb-in).
3. For manual transaxle, install the following:
  - a. Install flywheel. Apply Threadlock and Sealer EOAZ-19554-AA (ESE-M4G204-A) or equivalent to flywheel bolts. Tighten retaining bolts to 96-103 N·m (7 1-76 lb-ft).
  - b. Position clutch disc using Clutch Aligner T74P-7 137-K or equivalent.
  - c. Install pressure plate. Tighten retaining bolts to 18-26 N·m (14-19 lb-ft).
4. For automatic transaxle, install flywheel. Tighten retaining bolts to 96-103 N·m (7 1-76 lb-ft).
5. Install intermediate axle shaft and bearing, if equipped. Tighten bearing mount retaining bolts to 37-52 N·m (28-38 lb-ft).
6. For manual transaxle, install as follows:
  - a. Position transaxle to engine and install retaining bolts.
  - b. Tighten bolts "A" to 89-117 N·m (66-86 lb-ft).
  - c. Tighten bolts "B" to 37-52 N·m (29-38 lb-ft).
7. For automatic transaxle, install as follows:
  - a. Position transaxle to engine and install retaining bolts.
  - b. Tighten bolts "A" to 55-80 N·m (41-59 lb-ft).
  - c. Align torque converter and flywheel. Install retaining bolts, tighten to 34-49 N·m (25-36 lb-ft).
  - d. Install cover plate. Tighten retaining bolts "B", to 7-10 N·m (62-88 lb-in).
  - e. Install gusset plate(s), if removed. Tighten retaining bolts on engine to 37-52 N·m (28-38 lb-ft). Tighten bolts to transaxle to 55-80 N·m (41-59 lb-ft).

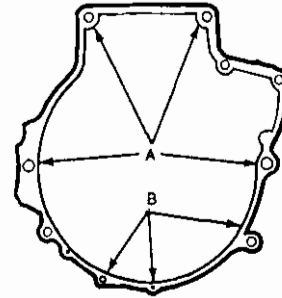

A13147-A

8. Install starter. Tighten retaining bolts to 31-46 N·m (23-34 lb-ft).
9. Install intake manifold support bracket. Loosely install all bolts first. Tighten upper bolts to 31-46 N·m (23-34 lb-ft). Tighten lower bolts to 31-46 N·m (23-34 lb-ft).
10. Install starter bracket to manifold support bolt. Tighten to 19-25 N·m (14-18 lb-ft).

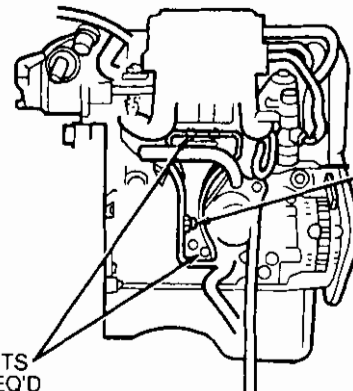

BOLT  
1 REQ'D  
TIGHTEN TO  
19-25 N·m  
(14-18 LB-FT)

BOLTS  
4 REQ'D  
TIGHTEN UPPER BOLTS THEN  
LOWER BOLTS TO 31-46 N·m (23-34 LB-FT)

A13148-B

11. On turbocharged engines, install turbocharger inlet tube.
12. Using Rotunda Portable Crane 077-00043 or equivalent, lower engine and transmission assembly into vehicle. Before engine contacts engine mounts, route starter, alternator and oil pressure sender wiring and connect oil pressure sender.
13. Lower engine until front mount seats on crossmember. Install through bolt on RH engine mount. Do not tighten.
14. Remove lifting crane.
15. Raise vehicle with a hoist. Refer to Section 00-02.

## REMOVAL AND INSTALLATION (Continued)

16. Align rear engine mount to crossmember and install retaining nuts to front and rear engine mounts. Tighten front mount nuts to 64-89 N·m (48-65 lb-ft). Tighten rear mount nut to 32-47 N·m (24-34 lb-ft).

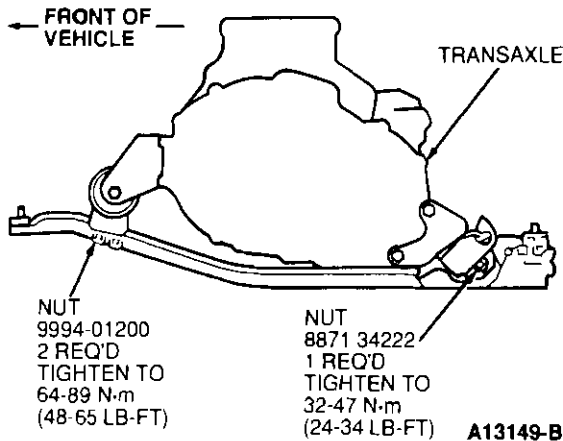

17. On manual transaxles, connect shift coupling and stabilizer. Tighten linkage retaining nut to 16-22 N·m (12-16 lb-ft). Tighten stabilizer to 31-46 N·m (23-34 lb-ft).
18. On automatic transaxles, connect shift linkage and oil cooler lines. Tighten linkage retaining bolt to 8-11 N·m (7.1-9.7 lb-in). Tighten shift cable pivot nut to 44-64 N·m (33-47 lb-ft). Tighten oil cooler hose clamps.
19. Connect front exhaust pipe to manifold (or turbocharger).
20. Install exhaust pipe to support bracket. Tighten retaining bolts to 43-61 N·m (32-45 lb-ft).
21. Tighten manifold (or turbocharger) nuts to 39-57 N·m (29-42 lb-ft).
22. Attach rubber exhaust hangers.
23. Position cross brace. Tighten retaining nut and bolt to 35-50 N·m (26-36 lb-ft). Tighten right A-arm front bolt to 97-117 N·m (72-86 lb-ft).
24. Install drive axles to transaxle.
25. Install ball joint retaining bolts. Tighten to 43-54 N·m (32-40 lb-ft).
26. Mount A/C compressor to engine, if required. Tighten lower retaining bolts to 39-54 N·m (29-40 lb-ft).
27. Install splash guards.
28. Install tire and wheel assemblies. Tighten wheel lug nuts to 90-120 N·m (67-88 lb-ft).
29. Lower vehicle. Install upper A/C compressor retaining bolts, if required. Tighten to 39-54 N·m (29-40 lb-ft).
30. Tighten RH engine mount through bolt to 45-65 N·m (34-47 lb-ft).
31. Connect generator wiring.

32. Position power steering pump bracket on stud. Lower power steering into engine compartment.
33. Install power steering pump bracket retaining bolts and nut. Tighten to 47-66 N·m (35-48 lb-ft).
34. Install power steering pump and belt. Tighten adjustment nut to 37-52 N·m (28-38 lb-ft). Tighten pivot bolt to 31-46 N·m (23-34 lb-ft).
35. Install engine oil dipstick and dipstick retaining clip.
36. Install ground strap and ground wire to cylinder head.
37. Install clutch cable, if manual transaxle / turbocharged. Connect clutch hydraulic line if manual transaxle / naturally aspirated. Refer to Section 08-02.
38. Connect transmission electrical connectors.
39. Connect engine electrical connectors.
40. Connect fuel lines to fuel filter and pressure regulator.
41. Install intake air tube to throttle body.
42. Install charge air cooler hoses, if turbocharged.
43. Install air cleaner assembly brackets. Refer to Section 03-12.
44. Install air cleaner assembly, with VAF attached. Refer to Section 03-12.
45. Install intake air tube.
46. Connect ignition coil and VAF connectors.
47. Connect coolant crankcase and idle air control (IAC) (9F7 15) hoses. Install vacuum hoses in correct locations as noted in disassembly.
48. Connect accelerator cable. Install retaining bracket. Refer to Section 10-02.
49. Install power brake booster hose.
50. Remove speedometer cable from transaxle. Fill transaxle to specification. Refer to Section 07-01, 07-03A or 07-03B.
51. Install speedometer cable. Connect speedometer cable connector.
52. Fill engine oil to specification. Refer to Section 00-03.
53. Install radiator / fan assembly. Tighten bracket retaining bolts to 8-11 N·m (7.1-9.7 lb-in). Connect coolant hoses and fan electrical connector.
54. Fill coolant to specification. Refer to Section 03-03.
55. Install hood. Tighten retaining bolts to 20-28 N·m (15-20 lb-ft). Connect washer hose.
56. Install battery tray support. Install battery tray, battery and battery hold down. Connect battery terminals. Refer to Section 14-01.
57. Evacuate and recharge air conditioning system, if required. Refer to Section 12-00.
58. Start engine. Check for proper operation.
59. Road test vehicle. Check clutch and transaxle for proper operation.



### REMOVAL AND INSTALLATION (Continued)

#### Cylinder Head

##### Removal

1. Release fuel pressure. Refer to Section 10-01.
2. Drain cooling system. Refer to Section 03-03.
3. Disconnect negative battery terminal.
4. Remove intake air tube from throttle body. Disconnect air bypass hoses.
5. Remove spark plug wires and retainers.
6. Remove intake air tube from air cleaner assembly.
7. Disconnect coolant hose from thermostat cover. Disconnect vacuum hoses and coolant hoses from throttle body and intake manifold.
8. Disconnect throttle cable and remove retaining brackets and cable. Refer to Section 10-02.
9. Disconnect fuel lines at fuel filter and pressure regulator. Refer to Section 10-01.
10. Disconnect main harness connector.
11. Disconnect oxygen sensor connector and remove ground connection retaining screw at bracket.
12. Disconnect charge air cooler tubes from turbocharger, if equipped.
13. Remove ground wire and strap retaining bolts at front sides of cylinder head.
14. Remove timing belt covers, and timing belt as outlined.
15. On turbocharged vehicles, remove exhaust manifold and turbocharger as an assembly. Refer to Section 03-04B.
16. On naturally aspirated engines, disconnect front exhaust pipe from exhaust manifold.
17. Remove intake manifold support upper retaining bolts.
18. Remove cylinder head cover.
19. Remove cylinder head and intake manifold as an assembly.
20. Separate intake manifold from cylinder head, if required.
21. Remove exhaust manifold, if required (naturally aspirated engines).

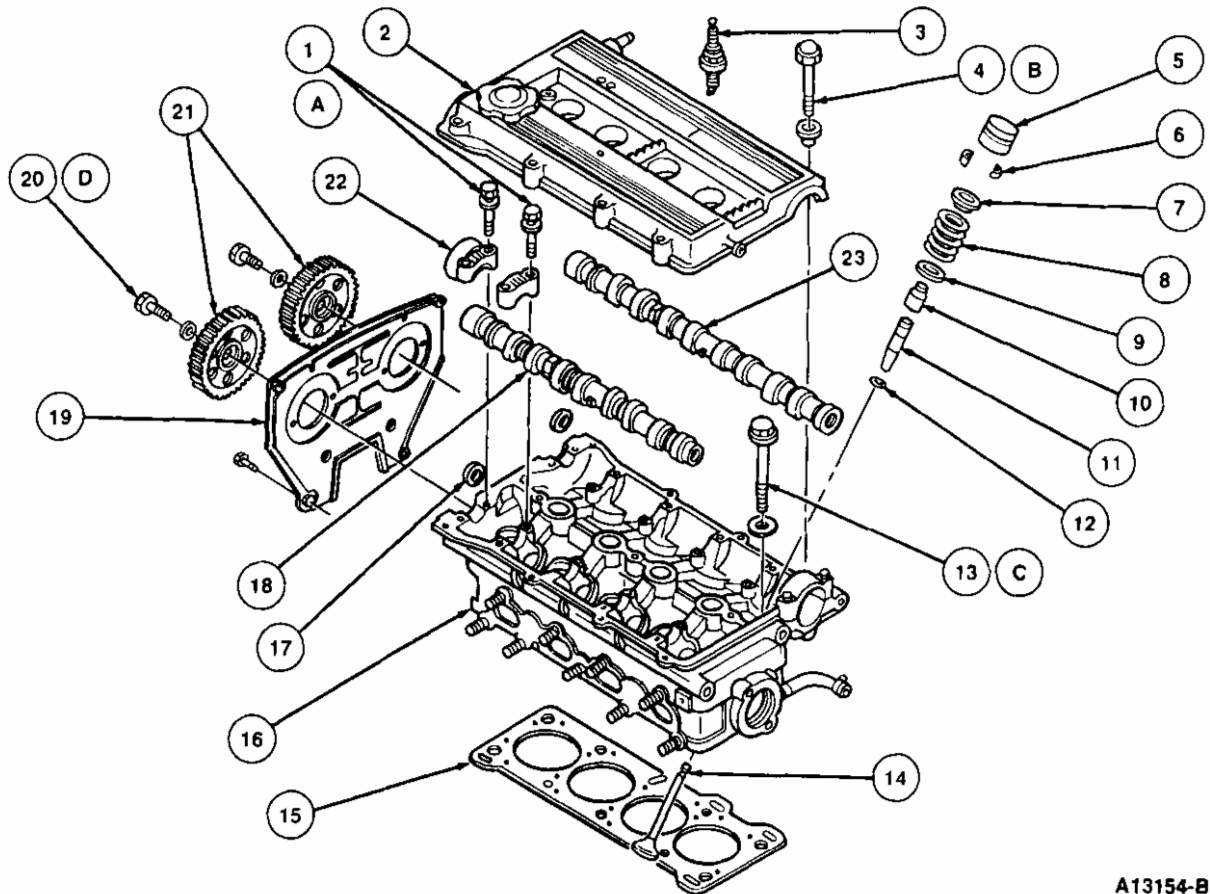

A13154-B

## REMOVAL AND INSTALLATION (Continued)

Item	Part Number	Description	Item	Part Number	Description
1A	6L293	Bolt (20 Req'd)	15	6251	Cylinder Head Gasket
2	6582	Cylinder Head Cover	16	6049	Cylinder Head
3	—	Spark Plug	17	6026	Camshaft Seal (2 Req'd)
4B	6A548	Bolt (8 Req'd)	18	6250	Exhaust Camshaft
5	6C501	HLA	19	6019	Seal Plate
6	6518	Valve Keepers	20D	6279	Bolt (2 Req'd)
7	6514	Valve Spring Retainer	21	6256	Camshaft Pulley
8	6513	Valve Spring	22	—	Bearing Caps (10 Req'd)
9	—	Spring Seat	23	6250	Intake Camshaft
10	6571	Valve Stem Seal	A		Tighten to 11-14 N·m (9-10 Lb-Ft)
11	—	Valve Guide	B		Tighten to 8-11 N·m (7-9 Lb-In)
12	—	Circlip	C		Tighten to 76-81 N·m (56-59 Lb-Ft)
13C	—	Bolt (10 Req'd)	D		Tighten to 49-61 N·m (37-45 Lb-Ft)
14	6507	Valve			

## Installation

1. Install exhaust manifold with new gaskets. Ensure use of two piece gasket. Heavy gasket installs first. Tighten retaining nuts to 39-57 N·m (29-42 lb-ft).
2. Install intake manifold to cylinder head, if removed. Use new gasket.  
NOTE: Ensure coolant passage openings in gasket align with manifold and cylinder head.
3. Tighten retaining nuts and bolts to 19-25 N·m (14-18 lb-ft).

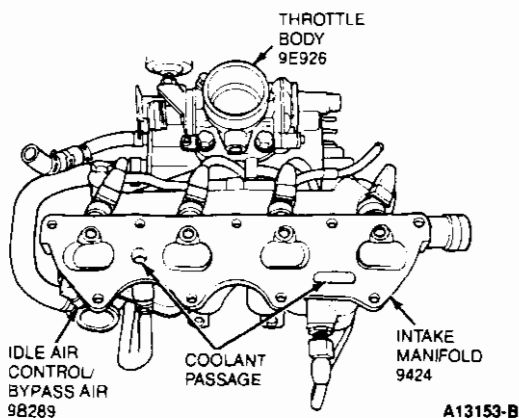

4. Clean head gasket surfaces on cylinder head and cylinder block. Position new head gasket on block.
5. Carefully set cylinder head on block.
6. Tighten cylinder head retaining bolts in sequence shown. First to 20-34 N·m (15-25 lb-ft), then to 76-81 N·m (56-59 lb-ft).

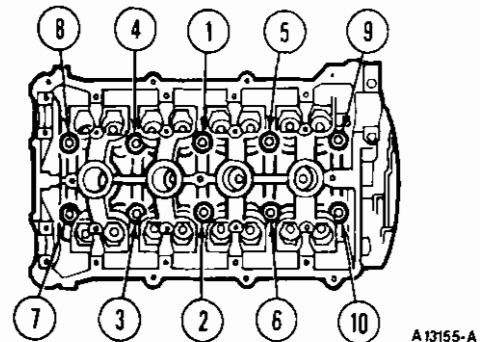

7. Install intake manifold support upper retaining bolts. Tighten to 31-46 N·m (22-39 lb-ft).
8. Install timing belt and covers, as outlined.
9. Install cylinder head cover. Tighten retaining bolts to 8-11 N·m (7-9 lb-in).
10. Connect front exhaust pipe to exhaust manifold, on naturally aspirated engine. Tighten retaining nuts to 31-46 N·m (23-33 lb-ft).
11. Install exhaust manifold and turbocharger assembly (on turbocharged engines). Refer to Section 03-04B.
12. Install ground wire and strap to cylinder head with retaining bolts.
13. Connect charge air cooler hoses, if equipped.
14. Connect oxygen sensor connector and install ground wires to bracket on cylinder head with retaining screw.
15. Connect main engine harness connector.
16. Connect fuel lines to fuel filter and pressure regulator.
17. Install throttle cable and retaining brackets. Refer to Section 10-02.

**REMOVAL AND INSTALLATION (Continued)**

- |   |  |
|---|--|
| <ul style="list-style-type: none"> <li>18. Install coolant hoses and vacuum lines to intake manifold and throttle body.</li> <li>19. Install coolant hose to thermostat cover.</li> <li>20. Install intake air tube to air cleaner.</li> <li>21. Install spark plug wires and retainers.</li> </ul> | <ul style="list-style-type: none"> <li>22. Install intake air tube to throttle body. Connect idle air control hoses.</li> <li>23. Fill cooling system. Refer to Section 03-03.</li> <li>24. Connect negative battery terminal.</li> <li>25. Start engine. Check for proper operation.</li> </ul> |
|---|--|

**Timing Belt****Removal**

- |   |   |
|---|---|
| <ul style="list-style-type: none"> <li>1. Raise vehicle on hoist. Refer to Section 00-02.</li> <li>2. Remove right front tire and wheel assembly. Remove RH splash guard.</li> <li>3. Lower vehicle.</li> <li>4. Remove spark plugs. Set engine timing to TDC on No. 1 cylinder.</li> <li>5. Remove generator and power steering belts. Refer to Section 03-05.</li> <li>6. Remove oil dipstick.</li> </ul> | <ul style="list-style-type: none"> <li>7. Remove water pump pulley.</li> <li>8. Remove crankshaft pulley, damper and baffle plate.</li> <li>9. Remove upper timing belt cover.</li> <li>10. Remove center and lower timing belt covers.</li> <li>11. Remove timing belt tension spring.</li> <li>12. Loosen timing belt tension pulley.</li> <li>13. Support engine with floor jack and remove RH engine mount as outlined.</li> </ul> <p>NOTE: Mark timing belt rotation direction before removal.</p> <ul style="list-style-type: none"> <li>14. Remove timing belt.</li> </ul> |
|---|---|

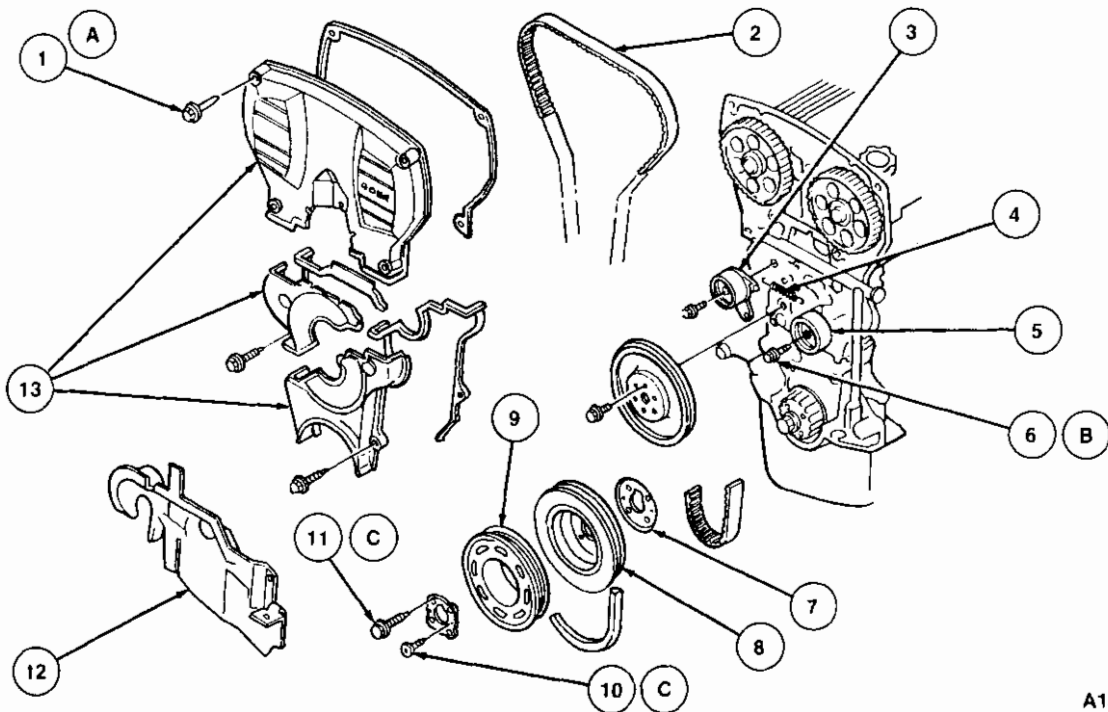

A13513-B

Item	Part Number	Description	Item	Part Number	Description
1A	9979 60635	Bolt (8 Req'd)	9	6A312	Crankshaft Pulley
2	6268	Timing Belt	10C	—	Screw (2 Req'd)
3	6K254	Tension Pulley	11C	6A345	Bolt (4 Req'd)
4	6L273	Tension Spring	12	—	Splash Guard
5	6M250	Idler Pulley	13	6019	Timing Belt Covers

(Continued)

## REMOVAL AND INSTALLATION (Continued)

Item	Part Number	Description	Item	Part Number	Description
6B	6K282	Bolt (2 Req'd)	A		Tighten to 8-11 N·m (7.1-9.7 Lb·In)
7	6306	Baffle Plate	B		Tighten to 37-52 N·m (28-38 Lb·Ft)
8	6312	Crankshaft Damper	C		Tighten to 12-17 N·m (10-12 Lb·Ft)

**Inspection****Timing Belt Tension Spring**

When servicing the timing belt, check the free length of the timing belt tension spring. Replace if out of specification.

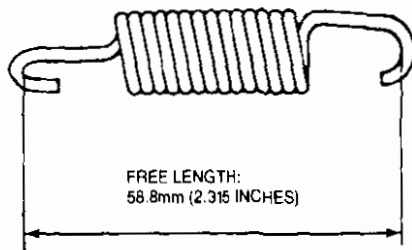

A13510-A

**Timing Belt**

**CAUTION: Never twist, turn inside out, or bend timing belt. Keep belt away from grease and oil.**

Replace the timing belt if affected by grease or oil. Check the timing belt for wear, tears, peeling, cracks or hardening. Replace the belt, if required.

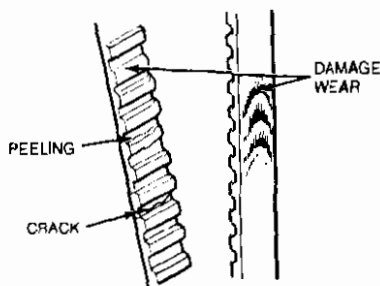

A14291-A

**Tensioner and Idler Pulleys**

**CAUTION: Do not clean tensioner or idler pulleys with solvents. Wipe them clean only.**

Spin pulleys by hand and check for smooth rotation or abnormal noise. Replace, if required.

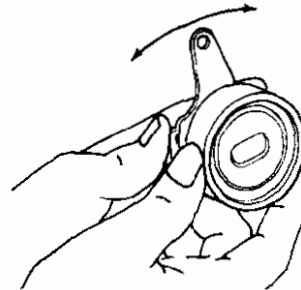

A14292-A

**Timing Belt Pulleys**

**CAUTION: Do not clean pulleys with solvents. Wipe them clean only.**

Inspect pulleys for wear, deformation, or damage. Replace, if required.

**Installation**

1. Ensure timing marks are properly positioned on camshafts and crankshaft as shown. The intake camshaft should have the letter "I" aligned with the arrow on the belt cover. The exhaust camshaft should have the letter "E" aligned with the arrow on the belt cover.

**REMOVAL AND INSTALLATION (Continued)**

2. The crankshaft key should align with the arrow as shown.

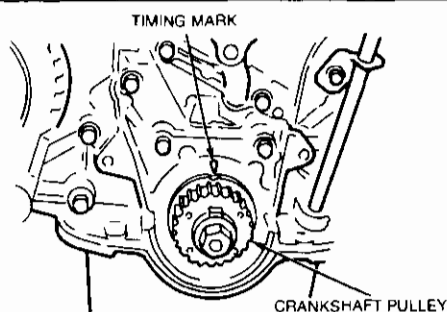
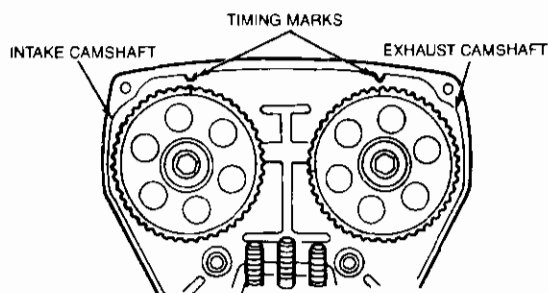

A13182-A

3. Tighten tension pulley with tension spring fully extended.
4. Install timing belt. Keep tension on the opposite side of the tensioner as tight as possible. Ensure rotation mark on belt is correct.
5. Turn crankshaft two full turns. Check alignment marks. If any mark is not aligned, remove timing belt and reset timing.
6. Loosen tension pulley retaining bolt to allow tension spring to tighten belt.
7. Tighten tension pulley retaining bolt to 37-52 N·m (28-38 lb-ft). Rotate engine two full turns. Ensure timing marks are aligned.
8. Measure timing belt tension between camshaft pulleys. Belt deflection should be 8.5-11.5 mm (0.34-0.45 inch). If incorrect, loosen tension pulley and repeat procedure. If proper tension cannot be achieved, replace tension spring.

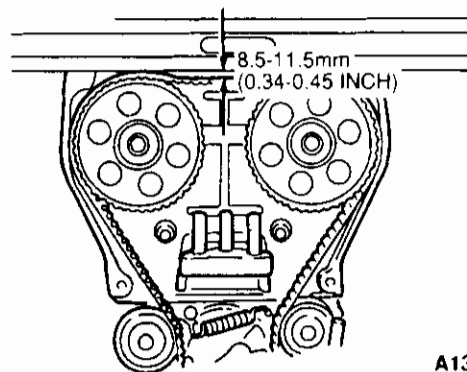

A13184-B

9. Install lower, center and upper timing belt covers. Tighten retaining bolts to 8-11 N·m (7-97 lb-in).
10. Install RH engine mount and lower engine. Tighten retaining nuts to 60-85 N·m (45-62 lb-ft).
11. Install crankshaft pulley, damper and baffle. Tighten baffle and damper retaining screws to 12-17 N·m (10-12 lb-ft). Tighten pulley retaining bolts to 12-17 N·m (10-12 lb-ft).
12. Install water pump pulley. Tighten retaining bolts to 8-11 N·m (71-97 lb-in).
13. Install generator and power steering belts. Refer to Section 03-05.
14. Install oil dipstick.
15. Raise vehicle.
16. Install splash guard and right front wheel and tire assembly. Tighten wheel lug nuts to 90-120 N·m (67-88 lb-ft).
17. Lower vehicle. Install spark plugs. Start engine. Check for proper operation.

**Camshaft****Removal**

1. Disconnect battery ground terminal.
2. Disconnect idle air control hoses and remove intake air tube.
3. Disconnect throttle cable and remove retaining brackets.
4. Remove cylinder head cover.
5. Remove timing belt, as outlined.

## REMOVAL AND INSTALLATION (Continued)

6. Remove camshaft pulley(s). Hold camshaft with wrench to remove pulley retaining bolt.

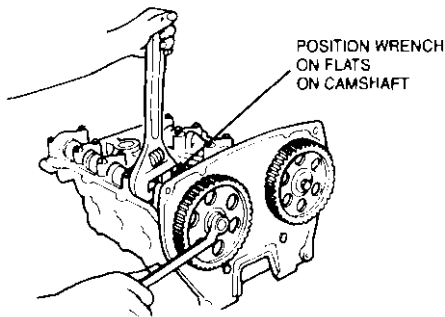

A13156-A

7. Remove seal plate.  
8. Remove camshaft seal using Locknut Pin Remover T78P-3504-N or equivalent.

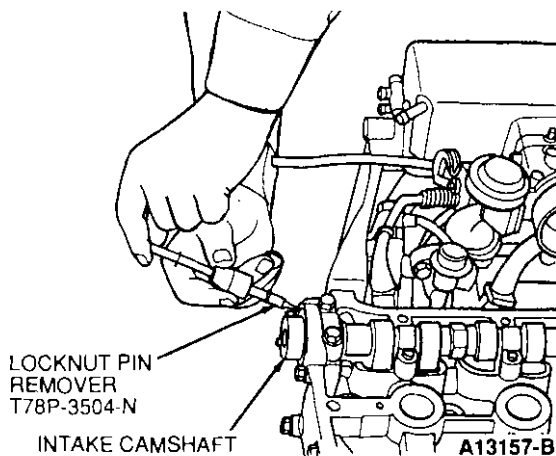

A13157-B

9. Remove distributor, if removing intake camshaft.  
10. Note numerical and directional markings on camshaft bearing caps for installation. Remove bearing cap retaining bolts alternately and gradually so as not to overstress camshaft.  
11. Remove camshaft.

NOTE: For camshaft service, refer to Service Procedures as outlined.

**Installation**

1. Lubricate camshaft bearings with clean engine oil. Position camshaft in cylinder head. Ensure all tappets are in place. Install intake camshaft with the "I" straight up and exhaust camshaft with the "E" straight up.  
2. Install bearing cap according to numbers and arrows. (Arrows to front of engine.) Tighten retaining bolts in sequence shown to 11-14 N-m (9-10 lb-ft).

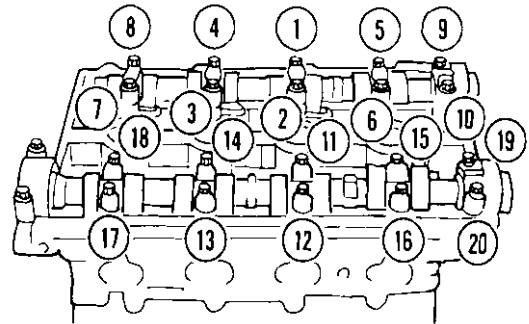

SEQUENCE SHOWN IS FOR INSTALLATION OF BOTH CAMSHAFTS. FOLLOW 1-10 SEQUENCE IF ONLY ONE CAMSHAFT IS BEING INSTALLED.

A13158-A

3. Install distributor, if removed.  
4. Install camshaft seal using Cam Seal Protector T90P-6256-AH and Cam Seal Replacer T90P-6256-BH or equivalent.

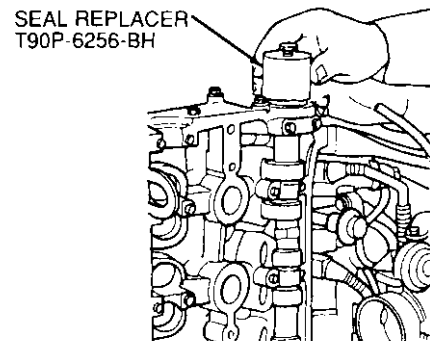
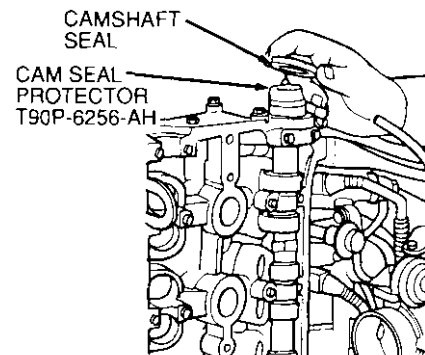

A13159-B

5. Install seal plate. Tighten retaining screws to 8-11 N-m (7-10 lb-ft).  
6. Install camshaft pulley. Tighten retaining bolt to 49-61 N-m (37-45 lb-ft).  
7. Install timing belt, as outlined.  
8. Install cylinder head cover. Tighten retaining bolts to 8-11 N-m (7-10 lb-ft).  
9. Install throttle cable and retaining brackets.  
10. Install intake air tube and connect idle air control hoses.  
11. Connect battery ground terminal.

**REMOVAL AND INSTALLATION (Continued)**

12. Start engine. Check for proper operation.

**Crankshaft, Main Bearings and Connecting Rod Bearings**

**Removal**

1. Remove timing belt, as outlined.
2. Remove transaxle. Refer to Section 07-01, 07-03A or 07-03B.
3. Remove oil pan, as outlined.
4. Remove oil pump, as outlined.
5. Remove flywheel and clutch, if required.
6. Remove rear crankshaft seal mounting flange.

7. Remove connecting rod bearing caps. Note numerical and directional position for proper assembly.
8. Loosen main bearing cap retaining bolts.
9. With an assistant remove main bearing caps and crankshaft. Note position of bearing caps for proper assembly.
10. Remove bearing inserts from connecting rods and rod caps, if required.
11. Remove main bearing inserts and thrust bearings, if required.

NOTE: For crankshaft service, refer to Service Procedures as outlined.

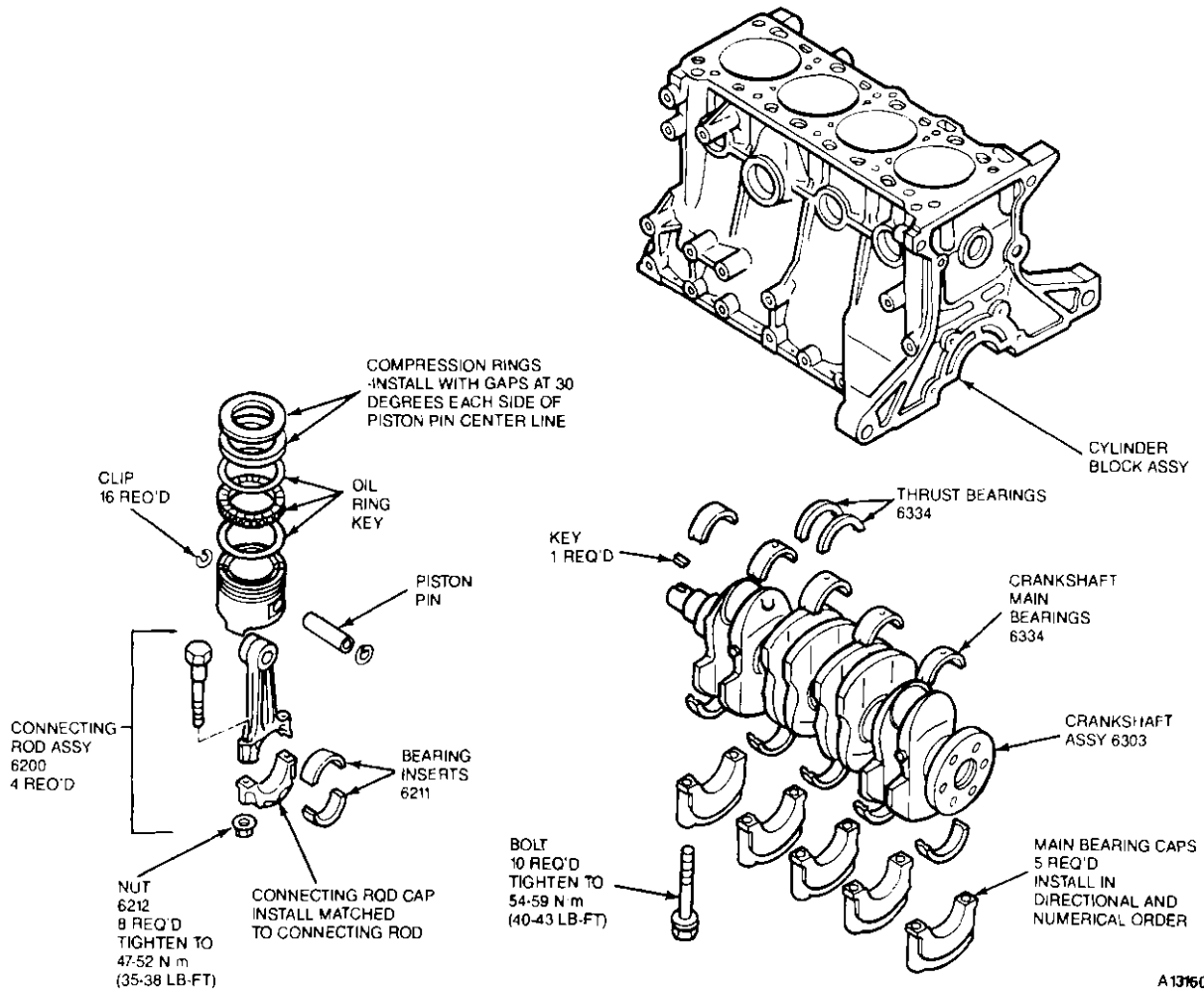

A13160-A

**REMOVAL AND INSTALLATION (Continued)****Installation**

1. Install upper connecting rod bearing inserts, if removed.
2. Install upper main bearing inserts, if removed.
3. Install lower main bearing inserts into main bearing caps.
4. With an assistant, install crankshaft using No. 2 bearing and cap.
5. Install thrust bearings.
6. Install remaining main bearings. Tighten retaining bolts to 54-59 N·m (40-43 lb-ft).
7. Install lower connecting rod bearing inserts, if removed. Install rod bearing caps. Tighten retaining nuts to 47-52 N·m (35-38 lb-ft).
8. Install rear crankshaft seal mounting flange. Tighten retaining bolts to 8-11 N·m (7.1-9.7 lb-in).
9. Install flywheel and clutch, if removed. Apply Threadlock and Sealer E0AZ-19554-AA (ESE-M4G204-A) (Type II) or equivalent to flywheel retaining bolts. Tighten bolts to 96-103 N·m (71-76 lb-ft).
10. Install oil pump, as outlined.
11. Install oil pan, as outlined.
12. Install transaxle. Refer to Section 07-01, 07-03A or 07-03B.
13. Install timing belt, as outlined.
14. Start engine. Check for leaks and proper operation.

**Intake Manifold****Removal**

1. Disconnect negative battery terminal.
2. Relieve fuel system pressure. Refer to Section 03-04A.
3. Drain cooling system. Refer to Section 03-03.
4. Disconnect charge air cooler hose and / or air intake tube. Disconnect idle air control hoses.
5. Disconnect main engine harness electrical connection and TP sensor connector.
6. Disconnect vacuum hoses from throttle body.
7. Disconnect fuel lines from fuel filter and pressure regulator.
8. Disconnect throttle cable.
9. Disconnect hoses from idle air control / bypass air valve.
10. Remove idle air control / bypass air valve retaining nut and bolt.
11. Remove intake manifold retaining bolts and nuts from support bracket and cylinder head.
12. Remove intake manifold and throttle body assembly.

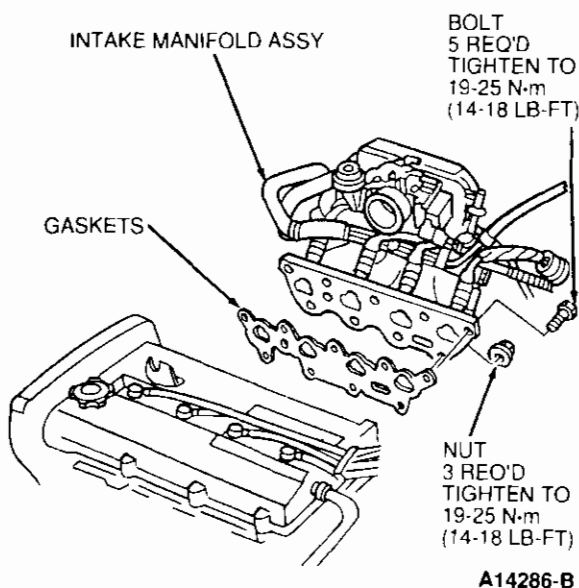

A14286-B

**Installation**

1. Install new intake manifold gasket. Ensure coolant passage openings align with openings in cylinder head and manifold.
2. Install intake manifold. Tighten retaining nut and bolts to 19-25 N·m (14-18 lb-ft). Tighten support bracket retaining bolts to 31-46 N·m (23-34 lb-ft).
3. Install idle air control / bypass air valve, connect air hoses.
4. Connect throttle cable.
5. Connect fuel lines to fuel filters and pressure regulator.
6. Connect main engine harness connector and TP sensor connector.
7. Connect vacuum lines to throttle body.
8. Connect charge air cooler hose and / or air intake tube. Connect idle air control hoses.
9. Fill cooling system. Refer to Section 03-03.
10. Connect negative battery terminal.
11. Start engine. Check for proper operation.

**Water Pump**

Refer to Section 03-03.

**Camshaft Seal****Removal**

1. Disconnect negative battery terminal.
2. Remove timing belt, as outlined.
3. Remove camshaft pulleys. Hold camshafts with wrench to remove pulley retaining bolt.



**REMOVAL AND INSTALLATION (Continued)**

4. Remove seal plate.
5. Remove camshaft seal using Locknut Pin Remover T78P-3504-N or equivalent.

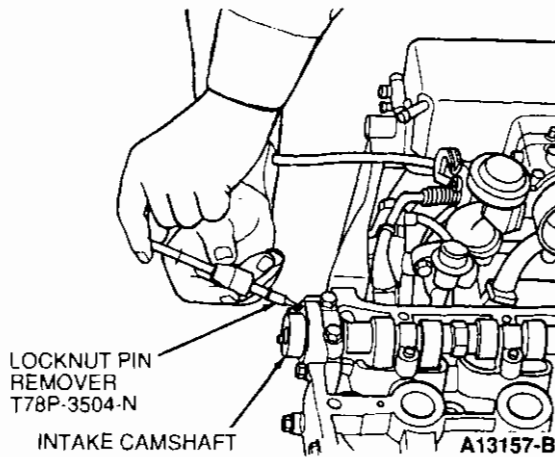
**Installation**

1. Install camshaft seal using Cam Seal Installer T90P-6256-BH and Cam Seal Protector T90P-6701-AH or equivalent.

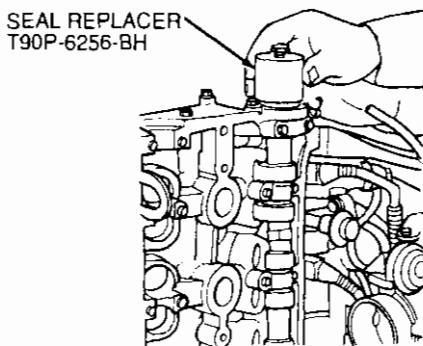
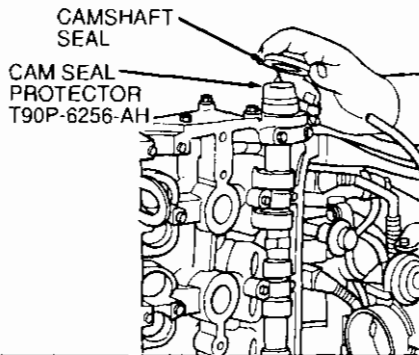

2. Install seal plate. Tighten retaining bolts to 8-11 N·m (71-97 lb-in).
3. Install camshaft pulleys. Install intake camshaft pulley with the "I" straight up, and the exhaust camshaft pulley with the "E" straight up. Tighten retaining bolt to 49-61 N·m (37-45 lb-ft). Hold camshaft with wrench while tightening retaining bolt.

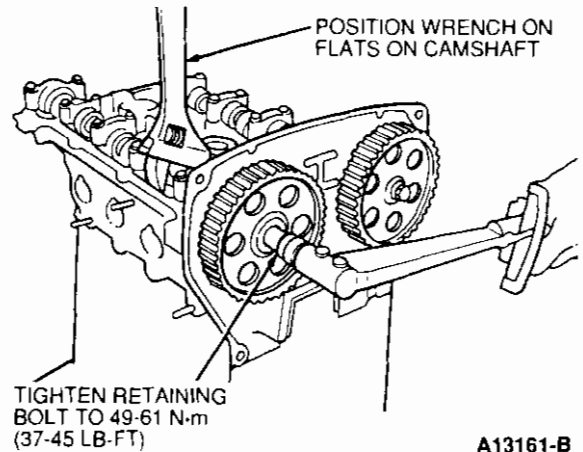

4. Install timing belt, as outlined.
5. Connect negative battery terminal.
6. Start engine. Check for leaks and proper operation.

**Exhaust Manifold****Naturally Aspirated Engine****Removal**

1. Remove intake air tube.
2. Remove front exhaust pipe to exhaust manifold retaining nuts.
3. Remove exhaust support bracket, if equipped.
4. Remove heat shield.
5. Disconnect oxygen sensor electrical connector.
6. Remove exhaust manifold.

**Installation**

1. Install exhaust manifold gaskets. Heavier gasket installed first.
2. Install exhaust manifold. Tighten retaining nuts to 39-57 N·m (29-42 lb-ft).
3. Connect oxygen sensor electrical connector.
4. Install manifold heat shield.
5. Install intake air tube.
6. Connect front exhaust pipe to exhaust manifold. Tighten retaining nuts to 31-46 N·m (23-33 lb-ft).
7. Install exhaust support bracket, if removed. Tighten engine mount bolt to 67-91 N·m (49-67 lb-ft).
8. Start engine. Check for leaks.

**Turbocharged Engine****Removal**

1. Remove exhaust manifold and turbocharger assembly. Refer to Section 03-04B.
2. Separate exhaust manifold from turbocharger.

**REMOVAL AND INSTALLATION (Continued)****Installation**

1. Install manifold to turbocharger assembly with new gasket. Tighten retaining nuts to 27-33 N·m (20-24 lb-ft).
2. Install exhaust manifold and turbocharger assembly. Refer to Section 03-04B.

**Throttle Body**

Refer to Section 03-04A.

**Thermostat**

Refer to Section 03-03.

**Valve Stem Seals****Cylinder Head Installed****Removal and Installation**

1. Remove timing belt and camshafts, as outlined.
2. Remove spark plugs.
3. To replace valve stem seals:
  - a. Rotate crankshaft to bring piston to TDC.
  - b. Pressurize cylinder with air using Rotunda Engine Cylinder Air Pressurization Kit 014-00705 or equivalent.
  - c. Remove hydraulic valve adjuster.
  - d. Remove valve spring and keepers using Valve Spring Compressor T89P-6565-A, Pivot Bar T87C-6565-A, Valve Spring Compressor Brackets T89P-6565-AZ and Valve Spring Compressor Screw Set T90P-6565-AH or equivalent.

e. Remove valve stem seal using Valve Stem Seal Remover T89P-6510-D or equivalent.

f. Lubricate new valve stem seal. Install seal using Valve Stem Seal Replacer T90P-6510-AH or equivalent.

4. Repeat procedure for each cylinder. Keep air charge in each cylinder until all valve springs in that cylinder are securely installed.
5. Install spark plugs.
6. Install camshafts and timing belt, as outlined.

**Oil Pan****Removal**

1. Raise vehicle. Refer to Section 00-02.
2. Drain engine oil.
3. Remove frame brace retaining bolt. Loosen RH A-arm front bolt and pivot brace downward.
4. Disconnect front exhaust pipe from exhaust manifold or turbocharger.
5. Remove front exhaust pipe bracket retaining bolts.
6. Loosen rubber exhaust hangers at catalyst. Allow exhaust to hang supported by mechanic's wire.
7. Disconnect turbocharger oil return hose, if required.
8. Remove oil pan retaining bolts.
9. Carefully pry oil pan loose from cylinder block.

**CAUTION: Do not force a prying tool between cylinder block and oil pan gasket surfaces.**

**REMOVAL AND INSTALLATION (Continued)**

10. Remove front and rear oil pan seals.

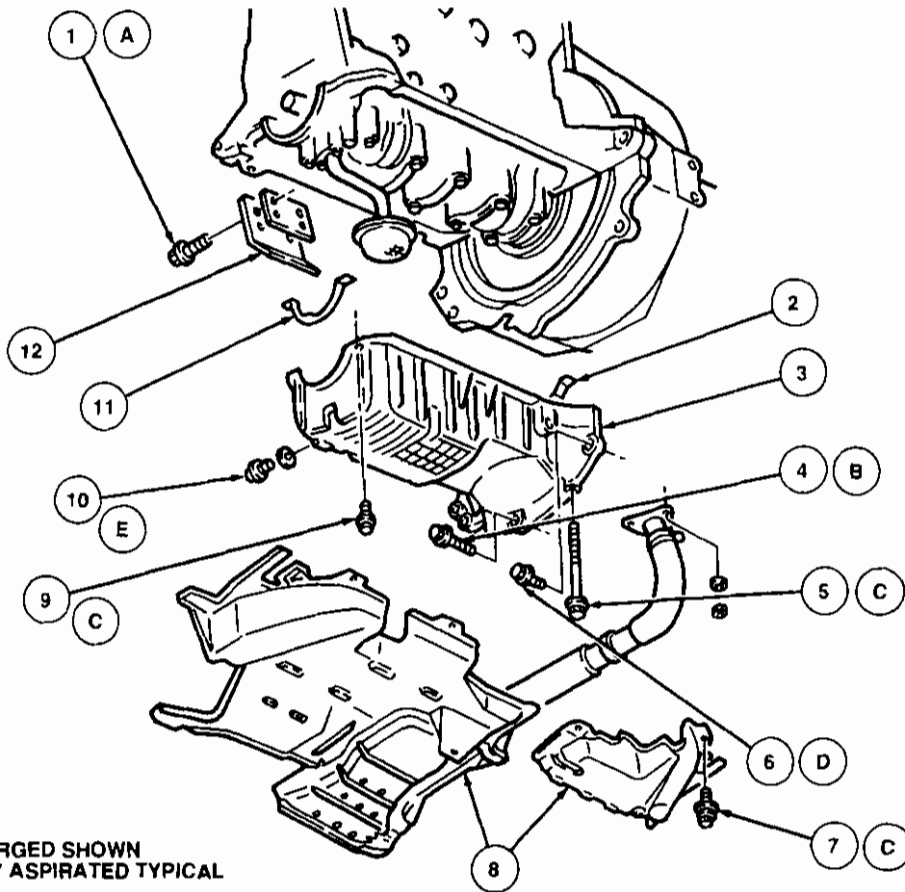

1.6L TURBOCHARGED SHOWN  
1.6L NATURALLY ASPIRATED TYPICAL

A13162-B

Item	Part Number	Description	Item	Part Number	Description
1A	—	Bolt (2 Req'd)	10E	—	Oil Drain Plug (1 Req'd)
2	—	Rear Oil Pan Seal	11	6722	Front Oil Pan Seal
3	6675	Oil Pan Assy	12	—	Front Exhaust Pipe Bracket Assy
4B	—	Bolt (1 Req'd)	A	—	Tighten to 43-61 N·m (32-45 Lb-Ft)
5C	6662	Bolt (2 Req'd)	B	—	Tighten to 19-25 N·m (14-19 Lb-Ft)
6D	—	Bolt (1 Req'd)	C	—	Tighten to 8-11 N·m (71-97 Lb-In)
7C	—	Bolt (8 Req'd)	D	—	Tighten to 37-52 N·m (27-38 Lb-Ft)
8	—	Engine Compartment Under Covers (if equipped)	E	—	Tighten to 29-41 N·m (22-30 Lb-Ft)
9C	—	Bolt (14 Req'd)			

**Installation**

1. Clean oil pan and cylinder block gasket surfaces.
2. Apply Silicone Gasket Sealant E8AZ-19562-A (ESE-M4G195-B) or equivalent to new front and rear oil pan seals. Install seals to cylinder block.
3. Apply Gasket Sealer E8AZ-19562-A (ESE-M4G195-B) or equivalent to oil pan gasket surface.

4. Install oil pan. Tighten retaining bolts to 8-11 N·m (71-97 lb-in).
5. Connect turbocharger oil return hose, if required.
6. Install rubber exhaust hanger to brackets.

**REMOVAL AND INSTALLATION (Continued)**

7. Install new gasket and connect front exhaust pipe to exhaust manifold or turbocharger. Tighten retaining nuts for naturally aspirated engines, to 31-46 N·m (23-34 lb-ft). For turbocharged engines, tighten nuts to 24-32 N·m (18-23 lb-ft).
8. Install front exhaust pipe bracket. Tighten retaining bolts to 43-61 N·m (32-45 lb-ft).
9. Pivot chassis cross brace into position. Tighten retaining bolt to crossmember to 35-50 N·m (26-36 lb-ft). Tighten RH A-arm front retaining bolt to 97-117 N·m (72-86 lb-ft).
10. Lower vehicle.
11. Fill engine oil. Start engine and check for leaks.

**Oil Pump****Removal**

1. Remove timing belt, as outlined.
2. Remove oil pan, as outlined.
3. Remove crankshaft timing belt pulley.
4. Remove oil strainer / pickup tube.
5. Remove oil pump retaining bolts.
6. Remove oil pump.

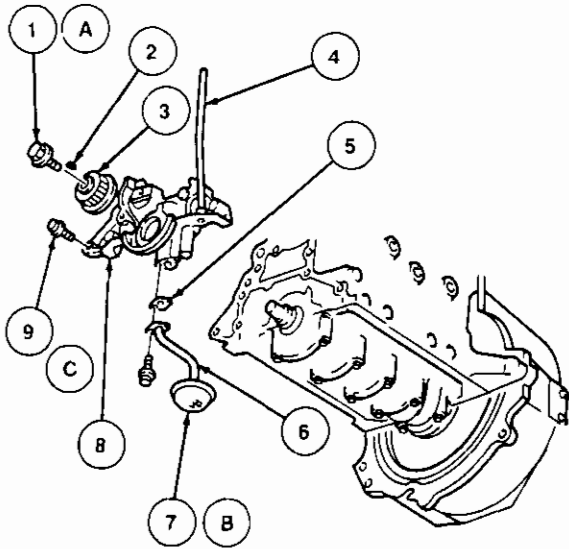

A13163-B

Item	Part Number	Description
1A	6A340	Bolt (1 Req'd)
2	6B316	Key
3	6306	Timing Belt Pulley
4	6754	Oil Dipstick Tube
5	6626	Gasket
6	6622	Oil Pick-Up Tube

(Continued)

Item	Part Number	Description
7B	9979-40620	Bolt (2 Req'd)
8	6600	Oil Pump Assy
9C	9979-40820	Bolt (4 Req'd)
A		Tighten to 108-118 N·m (80-87 Lb-Ft)
B		Tighten to 8-11 N·m (7.1-9.7 Lb-In)
C		Tighten to 19-25 N·m (14-18 Lb-Ft)

**Installation**

1. Clean gasket surfaces.
2. Install oil pump with new gasket.
3. Install retaining bolts. Tighten to 19-25 N·m (14-18 lb-ft).
4. Install oil strainer / pickup with new gasket. Tighten retaining bolts to 8-11 N·m (7.1-9.7 lb-in).
5. Install crankshaft timing belt pulley. Tighten retaining bolt to 108-118 N·m (80-87 lb-ft).
6. Install oil pan, as outlined.
7. Install timing belt, as outlined.

**Piston and Connecting Rod Assembly****Engine Installed****Removal**

1. Remove cylinder head, as outlined.
2. Remove oil pan, as outlined.
3. Remove connecting rod bearing cap retaining nuts.
4. Inspect top of cylinder wall and remove ridge using Cylinder Ridge Reamer T64L-6011-EA or equivalent, if required.

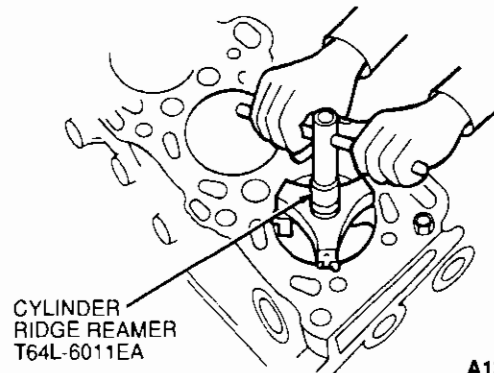

A13164-B

5. Push rod and piston up from bottom and remove.  
**NOTE:** For inspection and service procedures, refer to Section 03-00.

## REMOVAL AND INSTALLATION (Continued)

### Installation

1. Position compression rings at 30 degrees to each side of piston pin center line.

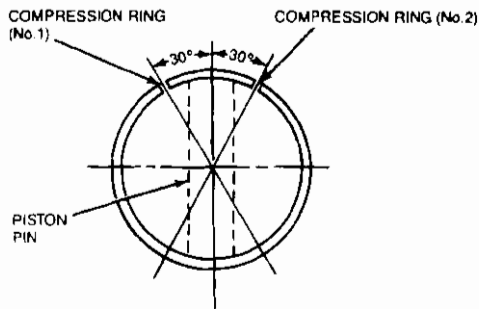

A13165-A

2. Compress piston rings using Piston Ring Compressor D81L-6002-C or equivalent. Install rubber hose over connecting rod studs to protect cylinder walls and crankshaft bearing surface.

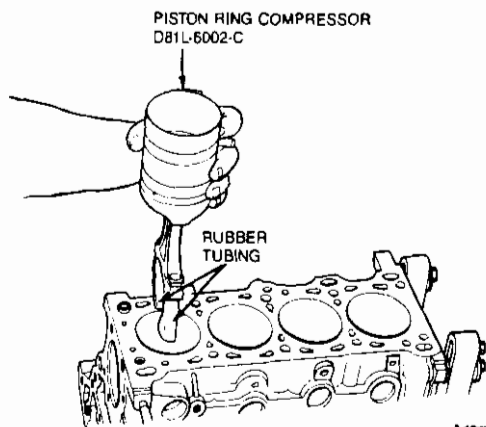

A13166-A

3. Position piston and rod assembly in cylinder block. Notch on piston goes to front of engine, (timing belt).
4. Tap piston and rod assembly into cylinder using wooden tool handle.

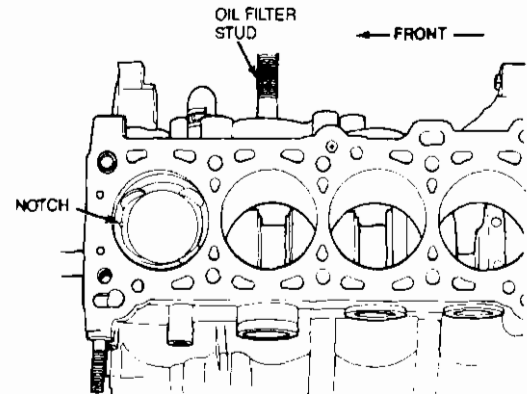

A13167-A

5. Install connecting rod to crankshaft. Remove rubber hose.
6. Install connecting rod bearing cap. Tighten retaining nuts to 47-52 N·m (35-38 lb-ft).
7. Install oil pan, as outlined.
8. Install cylinder head, as outlined.
9. Start engine. Check for leaks and proper operation.

### Crankshaft Oil Seal, Front

#### Removal

1. Remove timing belt, as outlined.
2. Remove crankshaft timing belt pulley.
3. Remove crankshaft seal using Locknut Pin Remover T78P-3504-N or equivalent.

#### Installation

1. Lubricate seal lip with clean engine oil.
2. Install crankshaft seal using Front Seal Installer T87C-6019-A or equivalent.
3. Install timing belt pulley. Tighten retaining bolt to 108-118 N·m (80-87 lb-ft).
4. Install timing belt, as outlined.

### Crankshaft Oil Seal, Rear

#### Removal

1. Remove transaxle. Refer to Section 07-01, 07-03A or 07-03B.
2. Remove clutch cover and disc, if required.
3. Remove flywheel.
4. Remove rear seal using Locknut Pin Remover T78P-3504-N or equivalent.

## REMOVAL AND INSTALLATION (Continued)

### Installation

1. Lubricate seal lip with clean engine oil.
2. Install crankshaft seal using Seal Replacer T87C-6701-A and Screw Set T90P-6565-AH or equivalent.
3. Install flywheel. Apply Threadlock and Sealer E0AZ-19554-AA (ESE-M4G204A, Type II) or equivalent to flywheel retaining bolts. Tighten retaining bolts to 96-103 N·m (71-76 lb-ft).
4. Install clutch assembly, if required.
5. Install transaxle.

### Core Plugs

#### Removal and Installation

To remove a core plug, drill a 12.7mm (1/2-inch) hole in the center of the plug and remove with an Impact Slide Hammer T59L-100-B or T50T-100-A or equivalent or pry it out with a large drift punch. On a small core plug, drill a 6.35mm (1/4-inch) hole in the center of the plug and pry it out with a small pin punch. Clean and inspect the plug bore.

Prior to installing a core plug, the plug bore should be inspected for any damage that would interfere with the proper sealing of the plug. If the bore is damaged it will be necessary to true the surface by boring for the next specified oversize plug.

Oversize (OS) plugs are identified by the OS stamped in the flat located on the cup side of the plug.

Coat the plug and / or bore lightly with an oil-resistant (oil galley) or Perfect Seal Sealing Compound B5A-19554-A (ESR-M18P2-A and ESE-M4G115-A) or equivalent, and install it according to the following procedure:

Install the core plug with the flanged edge outward. The maximum diameter of this plug is located at the outer edge of the flange. The flange on cup-type plug flares outward with the largest diameter of the outer (sealing) edge.

The flanged (trailing) edge must be below the chamfered edge of the bore to effectively seal the plugged bore.

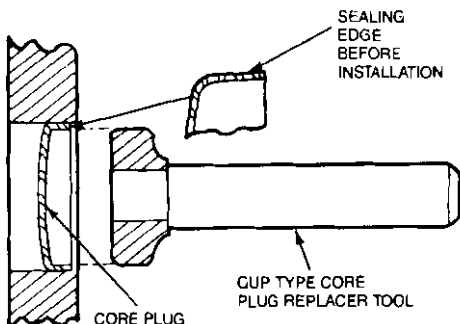

A13502-A

If the core plug replacing tool has a depth seating surface, do not seat the tool against a non-machined (casting) surface.

**CAUTION: It is imperative to install the plug into the machined bore by using a properly designed tool. Under no circumstances is the plug to be driven into the bore using a tool that contacts the flange. This method will damage the sealing edge and will result in leakage and/or plug blowout.**

## DISASSEMBLY AND ASSEMBLY

### Engine

NOTE: This procedure continues from Engine, Removal.

#### Disassembly

1. Remove intermediate axle shaft and bearing, if equipped.
2. Remove clutch, pressure plate and flywheel, if required.
3. Remove end plate.
4. Remove turbocharger inlet tube, if required.
5. Install necessary brackets and mount engine-to-engine stand.
6. Disconnect vacuum hoses from intake manifold and throttle body.
7. Disconnect coolant and PCV hoses from intake manifold.
8. Remove intake manifold and throttle body assembly.

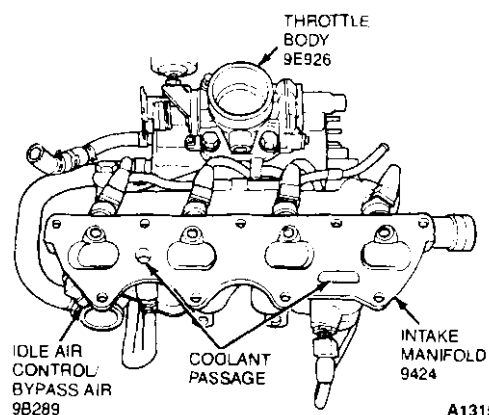

A13153-B

9. Remove heat shields from exhaust manifold, and turbocharger, if equipped.
10. Disconnect oil lines and coolant hoses from turbocharger, if equipped.
11. Remove turbocharger support bracket retaining bolts, if equipped.
12. Remove exhaust manifold or manifold / turbocharger assembly. Cover all turbocharger openings.

## DISASSEMBLY AND ASSEMBLY (Continued)

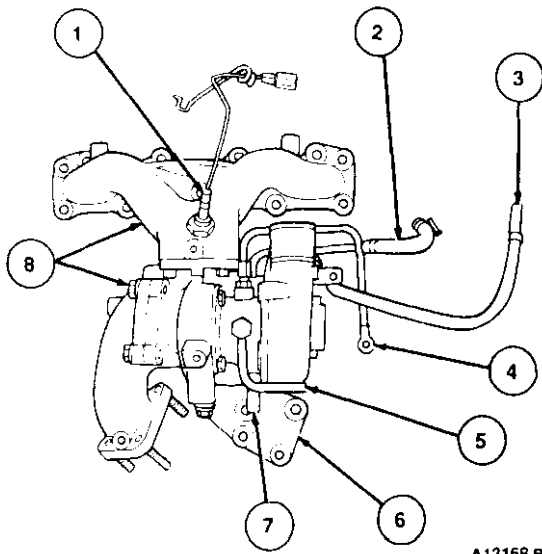

A13168-B

Item	Part Number	Description
1	9F472	Oxygen Sensor
2	—	Coolant Return Hose
3	—	Boost Control Vacuum Hose
4	—	Oil Pressure Hose
5	—	Coolant Inlet Connection
6	9449	Turbocharger Support Bracket
7	—	Oil Return
8	9G438	Exhaust Manifold/Turbocharger Assy

13. Remove coolant bypass tube (heater tube).
14. Remove distributor, spark plug wires and wire retainers.
15. Remove idle air control tube and bracket.
16. Remove oil filter and oil cooler, if equipped. Remove oil filter stud, if required.

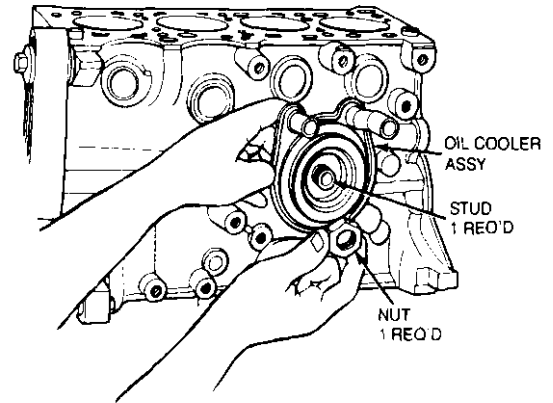

A13169-A

17. Remove oil pressure sensor and remove knock sensor, if equipped.

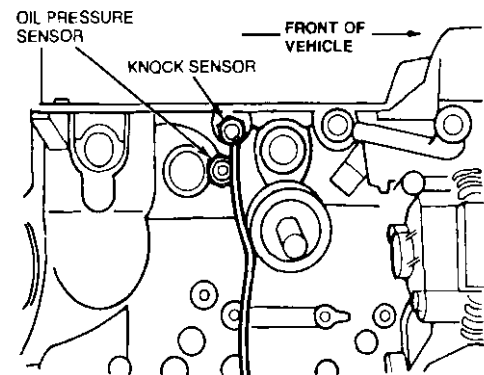

A13170-A

18. Remove exhaust pipe support bracket.
19. Remove generator and brackets.
20. Remove water pump pulley.
21. Remove crankshaft pulleys and baffle plate.
22. Remove timing belt covers.

## DISASSEMBLY AND ASSEMBLY (Continued)

23. Remove timing belt tension and idler pulleys, and tension spring.

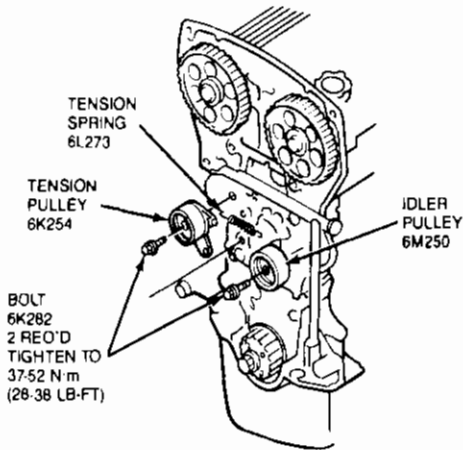

24. Mark timing belt direction of rotation and remove timing belt.
25. Remove oil dipstick bracket retaining bracket and bolt.
26. Remove water pump outlet.
27. Remove water pump.

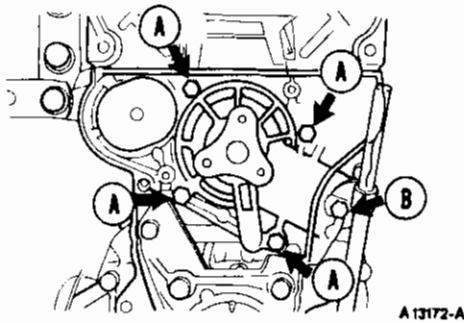

28. Remove cylinder head cover and gasket. Remove cylinder head.

NOTE: Evenly loosen retaining bolts in the order shown.

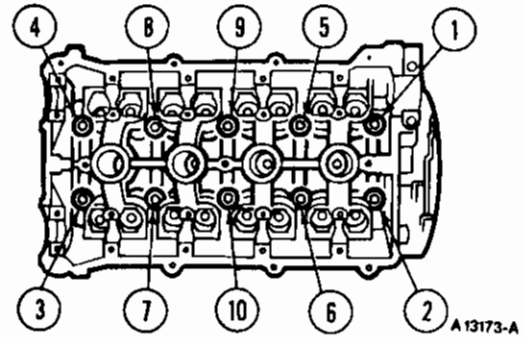

29. Remove RH engine mount bracket.
30. Remove crankshaft timing belt pulley.
31. Remove oil pan and seals.
- CAUTION: Use care not to pry against sealing surfaces.**
32. Remove oil pump pick-up tube.
33. Remove oil pump.

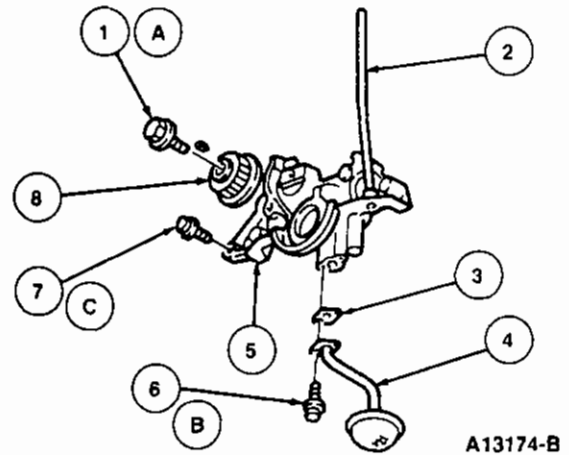

Item	Part Number	Description
1A	6A340	Bolt (1 Req'd)
2	6754	Oil Dipstick Tube
3	6626	Gasket
4	6622	Oil Pick-Up Tube
5	6600	Oil Pump Assy
6B	9979-40620	Bolt (2 Req'd)
7C	9979-40820	Bolt (4 Req'd)
8	6306	Timing Belt Pulley
A		Tighten to 108-118 N·m (80-87 Lb-Ft)
B		Tighten to 8-11 N·m (71-97 Lb-In)
C		Tighten to 19-25 N·m (14-18 Lb-Ft)

34. Remove rear crankshaft oil seal mounting flange.



**DISASSEMBLY AND ASSEMBLY (Continued)**

35. Mark positions of connecting rods and pistons for assembly. Ensure main bearing caps and rod bearing caps are numbered, or mark them for assembly.
36. Remove connecting rod bearing caps.
37. Inspect the tops of cylinder walls for ridges. Remove ridges, using Cylinder Ridge Reamer T64L-6011-EA or equivalent, if required.
38. Remove piston and connecting rod assemblies.
39. Remove crankshaft bearing caps and remove crankshaft.
40. Remove upper main bearings and thrust bearings.
41. Remove piston oil spray nozzles, if equipped.

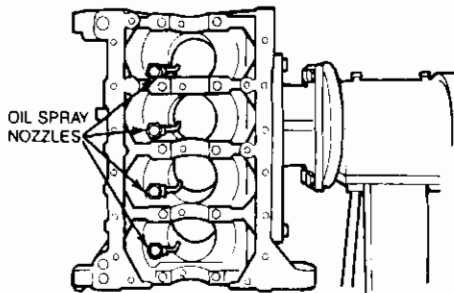

A13175-A

**NOTE:** For engine block service, refer to Service Procedures as outlined.

**Assembly**

1. Install piston oil spray nozzles. Use new sealing washers. Tighten bolt / fitting to 12-18 N·m (10-13 lb-ft).
2. Install upper main bearings and thrust bearings into cylinder block. Lubricate with clean engine oil. Oil grooves on thrust bearings must face crankshaft.

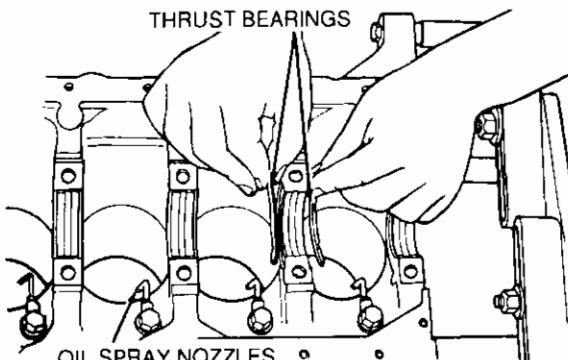

OIL SPRAY NOZZLES  
4 REQ'D  
TIGHTEN BOLT TO  
12-18 N·m  
(10-13 LB-FT)

A13176-B

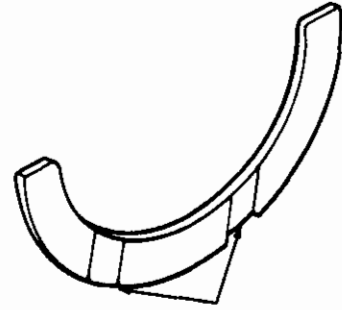

OIL GROOVES  
TOWARD  
CRANKSHAFT A14283-B

3. Position crankshaft into cylinder block.
4. Install lower main bearings into bearing caps. Install caps over crankshaft. Tighten retaining bolts to 54-59 N·m (40-43 lb-ft).
5. Install piston and connecting rod assemblies as follows:
  - a. Cover rod studs with rubber tubing to protect crankshaft and cylinder walls.
  - b. Position piston ring gaps at 30 degrees from piston pin centerline.

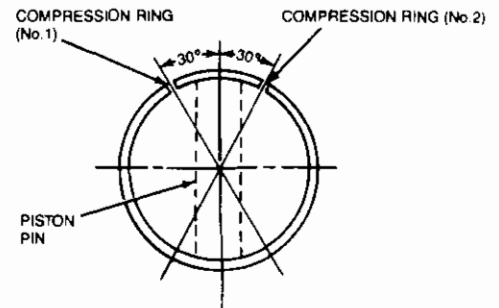

A13165-A

- c. Compress piston rings using Piston Ring Compressor D81L-6002-C or equivalent.

## DISASSEMBLY AND ASSEMBLY (Continued)

- d. Install upper connecting rod bearing inserts. Lubricate with clean engine oil. Lower piston assemblies into block, ensuring notches on top of pistons are to front (timing belt) of engine.

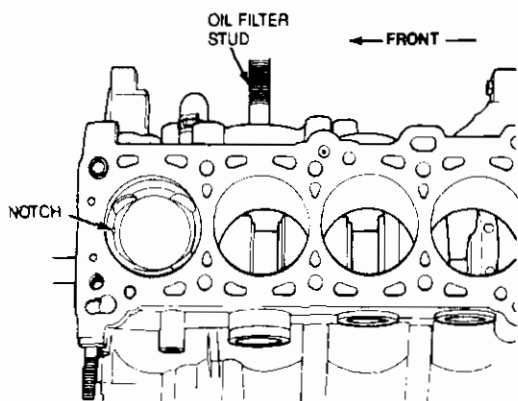

A13177-A

- e. Install lower rod bearing inserts into rod caps and lubricate with clean engine oil. Install rod caps. Tighten retaining nuts to 47-52 N·m (35-38 lb-ft).
6. Install rear crankshaft seal and mounting flange assembly with new gasket. Tighten retaining bolts to 8-11 N·m (71-97 lb-in).
  7. Install oil pump assembly with new gasket. Tighten retaining bolts to 19-25 N·m (14-18 lb-ft).
  8. Install oil strainer and pick-up tube with new gasket. Tighten retaining bolts to 8-11 N·m (71-97 lb-in).

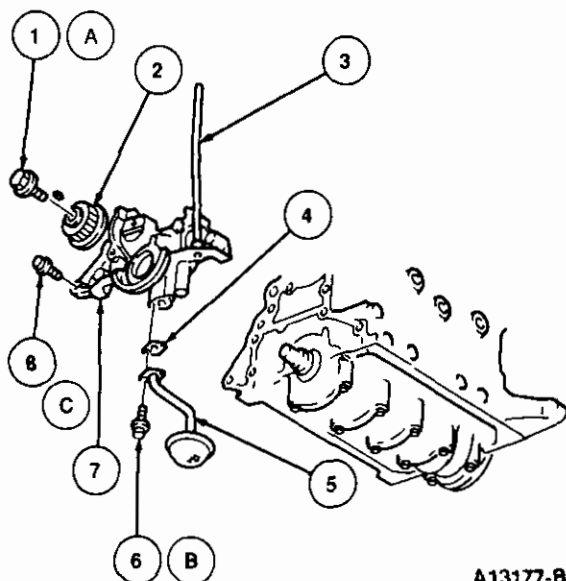

A13177-B

Item	Part Number	Description
1A	6A340	Bolt (1 Req'd)
2	6306	Timing Belt Pulley
3	6754	Oil Dipstick Tube
4	6626	Gasket
5	6622	Oil Pick-Up Tube
6B	9979-40620	Bolt (2 Req'd)
7	6600	Oil Pump Assy
8C	9979-40820	Bolt (4 Req'd)
A		Tighten to 108-118 N·m (80-87 Lb-Ft)
B		Tighten to 8-11 N·m (71-97 Lb-In)
C		Tighten to 19-25 N·m (14-18 Lb-Ft)

9. Apply Silicone Gasket and Sealant E8AZ-19562-A (ESE-M4G 195-B) or equivalent to front and rear oil pan seals. Install seals.

NOTE: Check oil pump and rear crank seal gaskets and trim away excess material that may cause interference with proper fit of oil pan.

10. Apply Silicone Gasket and Sealant E8AZ-19562-A (ESE-M4G 195-B) or equivalent to oil pan sealing surface. Install oil pan. Tighten retaining bolts to 8-11 N·m (71-97 lb-in).
11. Install oil pressure sensor. Tighten to 12-18 N·m (10-13 lb-ft).
12. Install knock sensor (turbocharged vehicles). Tighten to 20-34 N·m (15-25 lb-ft).

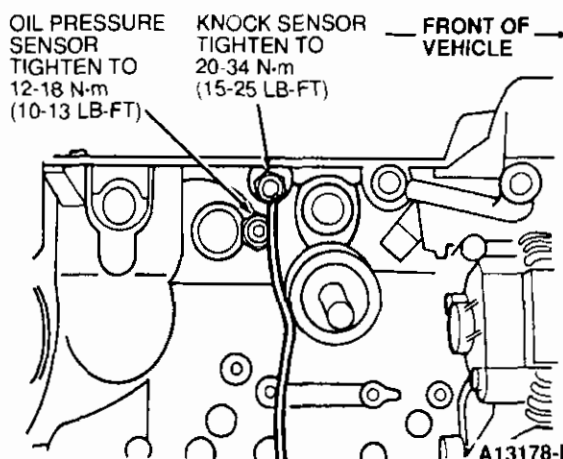

A13178-B

13. Install oil cooler. Tighten retaining nut to 29-39 N·m (22-28 lb-ft).
14. If removed, install oil filter stud. Install oil filter. Lubricate seal with clean engine oil prior to installing. Tighten by hand only.
15. Install crankshaft timing belt pulley. Tighten bolt to 108-118 N·m (80-87 lb-ft).
16. Ensure cylinder head gasket surfaces are clean and position new head gasket on cylinder block.
17. Position RH engine mount bracket.

**DISASSEMBLY AND ASSEMBLY (Continued)**

18. Install cylinder head. Tighten retaining bolts in sequence shown first to 20-34 N-m (15-25 lb-ft), then to 76-81 N-m (56-59 lb-ft).

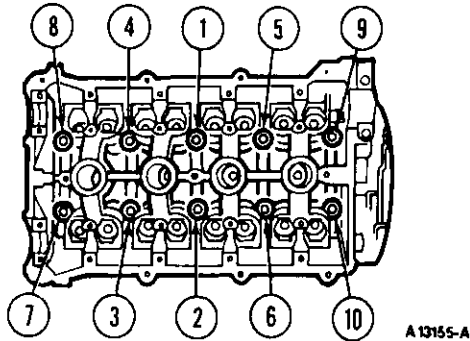

19. Install water pump with new gasket. Install water pump outlet, with new gasket, to water pump. Tighten retaining bolts to 19-25 N-m (14-18 lb-ft).

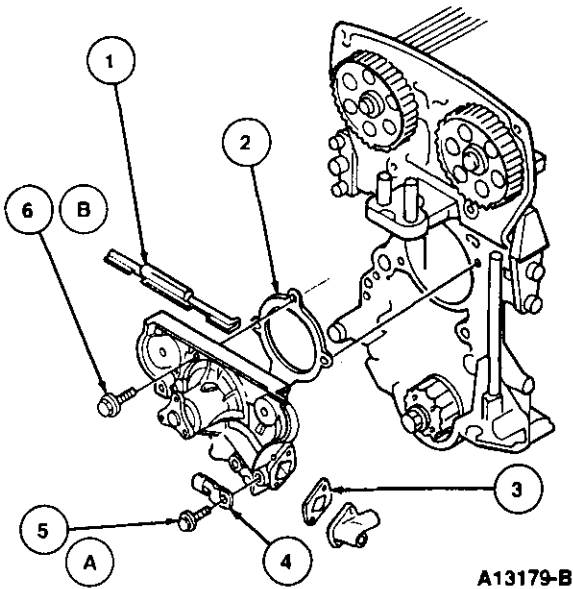

Item	Part Number	Description
1	—	Seal
2	—	Gasket
3	6626	Gasket
4	—	Oil Dipstick Bracket

(Continued)

Item	Part Number	Description
5A	—	Bolt (1 Req'd)
6B	9979-40830	Bolt (4 Req'd)
A		Tighten to 8-11 N-m (7 1-97 Lb-In)
B		Tighten to 19-25 N-m (14-18 Lb-Ft)

20. Install generator bracket and engine mount support. Tighten retaining bolts as follows: No. 1 47-66 N-m (35-48 lb-ft); No. 2 60-85 N-m (45-62 lb-ft); No. 3 93-117 N-m (69-86 lb-ft); No. 4 37-52 N-m (28-38 lb-ft).

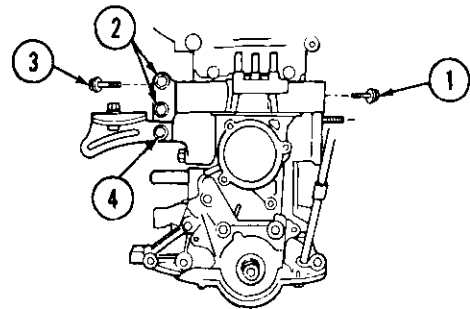

21. Install timing belt idler and tensioner pulleys. Tighten idler pulley retaining bolt only to 37-52 N-m (28-38 lb-ft).
22. Install tension spring. Fully extend tension spring and tighten tension pulley retaining bolt to 37-52 N-m (28-38 lb-ft).

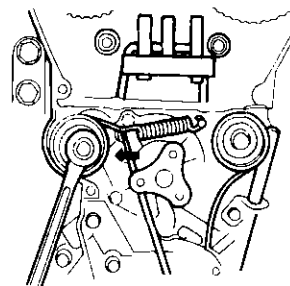

## DISASSEMBLY AND ASSEMBLY (Continued)

23. Align crankshaft and camshaft timing marks. Intake camshaft should have "I" mark aligned. Exhaust camshaft should have "E" aligned.

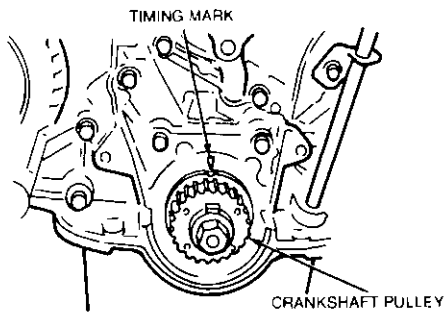
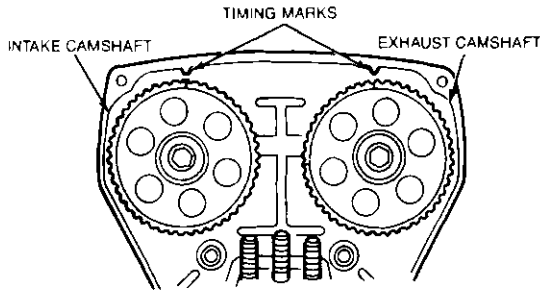

A13182-A

24. Install timing belt. Keep side of belt opposite tensioner as tight as possible.  
NOTE: If installing used belt, ensure belt is installed as marked during removal.
25. Rotate crankshaft two complete turns. Loosen tension pulley retaining bolt to allow spring to apply belt tension. Tighten pulley bolt to 37-52 N·m (28-38 lb-ft).
26. Rotate crankshaft two complete turns. Inspect timing marks. Remove belt and repeat procedure if not aligned properly.
27. Check belt tension. Deflection between camshaft pulleys should be between 8.5-11.5mm (0.34-0.45 inch).

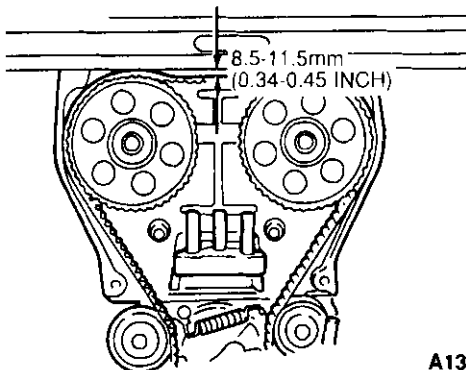

A13184-B

28. Install lower, center and upper timing belt covers. Ensure gaskets are in place. Tighten retaining bolts to 8-11 N·m (7.1-9.7 lb-in). Install oil dipstick tube bracket. Tighten bolt to 8-11 N·m (7.1-9.7 lb-in).

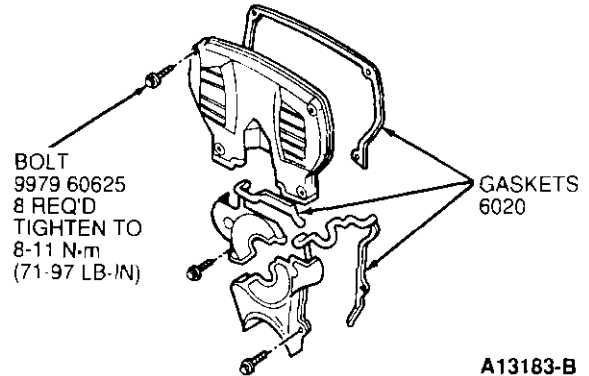

29. Install water pump pulley. Tighten retaining bolts to 8-11 N·m (7.1-9.7 lb-in).
30. Install baffle plate and crankshaft pulleys. Tighten retaining screws and bolts to 12-17 N·m (10-12 lb-ft).

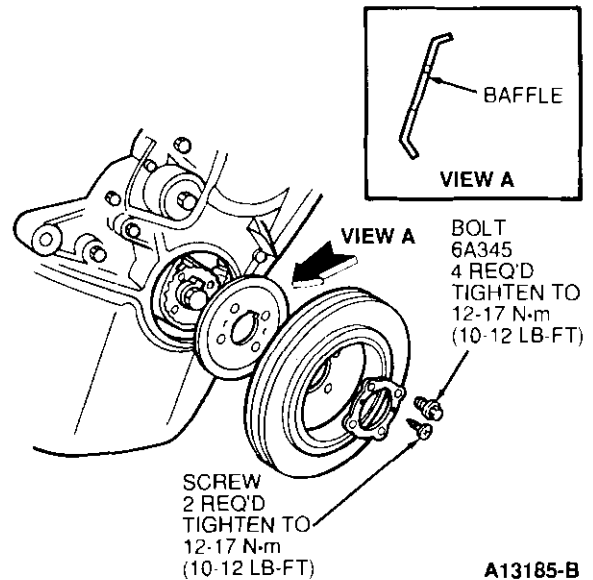

31. Install generator and generator belt. Tighten adjustment bolt to 19-25 N·m (14-18 lb-ft). Tighten pivot bolt to 37-52 N·m (28-38 lb-ft). Tighten support bracket bolt to 37-52 N·m (28-38 lb-ft).
32. Install cylinder head cover and gasket. Tighten retaining bolts to 8-11 N·m (7.1-9.7 lb-in).
33. Install new O-ring to distributor. Lubricate with clean engine oil and install distributor. Secure retaining bolts but do not fully tighten. Install ignition wires and retainers.

**DISASSEMBLY AND ASSEMBLY (Continued)**

34. Install intake manifold with new gasket.

NOTE: Ensure coolant passage openings in gasket align with openings in manifold and cylinder head. Tighten retaining nuts and bolts to 19-25 N·m (14-18 lb-ft).

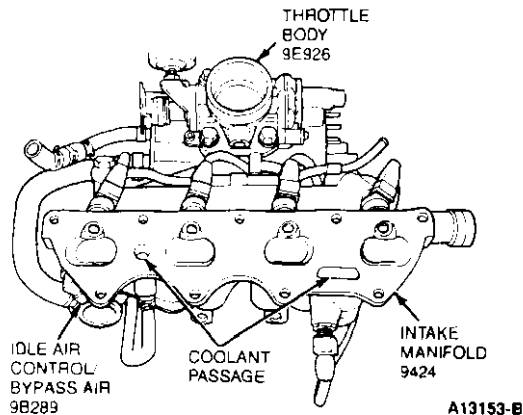

35. Install new O-ring to coolant bypass tube (heater bypass) and install tube to water pump outlet.
36. Install exhaust manifold gaskets.
- NOTE: Two piece gaskets must be used. Heavier gasket installed first.

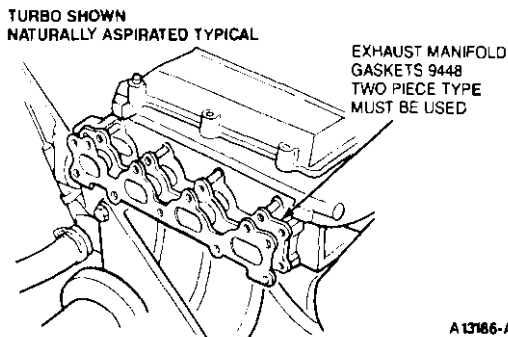

37. Install exhaust manifold. On turbocharged engines install as follows:
- Install exhaust manifold / turbocharger / support bracket assembly. Tighten manifold retaining nuts to 39-57 N·m (29-42 lb-ft).
  - Tighten turbocharger support retaining bolts to 43-61 N·m (32-45 lb-ft).
  - Install oil pressure line to turbocharger. Use new sealing washers on bolt. Tighten to 12-18 N·m (10-13 lb-ft). Connect oil return and coolant hoses.

38. On naturally aspirated engines, install exhaust manifold. Tighten retaining nuts to 31-46 N·m (23-33 lb-ft).
39. Install exhaust manifold (and turbocharger) heat shields.
40. Install front exhaust pipe support bracket. Tighten retaining bolts to 24-32 N·m (18-23 lb-ft).
41. Connect idle air control to the throttle body. Connect vacuum lines, air tubes and coolant hoses.

NOTE: Engine must be removed from engine stand to complete engine assembly. Remaining steps are outlined under Engine, Installation.

**Cylinder Head****Disassembly**

- Remove spark plugs.
- Remove camshaft pulleys. Hold camshaft with wrench to remove pulley retaining bolts.

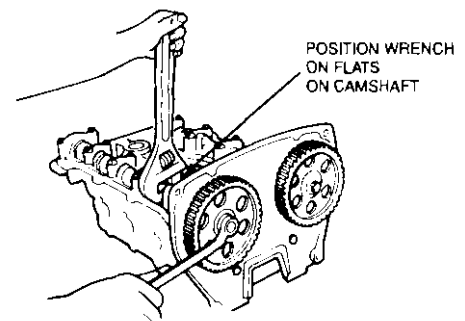

- Remove distributor.
  - Remove seal plate.
  - Remove camshaft bearing cap retaining bolts.
- CAUTION: Loosen retaining bolts alternately and evenly to prevent excessive stress to camshafts.**
- Remove camshaft bearing caps. Note numerical and directional positions for assembly.
  - Remove camshafts. Slide camshaft seals off ends of shafts.
  - Remove hydraulic lash adjusters (HLA). Set aside in order so they can be installed in the positions they are removed from.

## DISASSEMBLY AND ASSEMBLY (Continued)

9. Remove valves, springs, keepers and seats using Valve Spring Compressor T89P-6565-A1, Valve Spring Compressor Bar T87C-6565-A, Valve Spring Compressor Brackets T89P-6565-A2 and Valve Spring Compressor Screw Set T90P-6565-AH or equivalent.

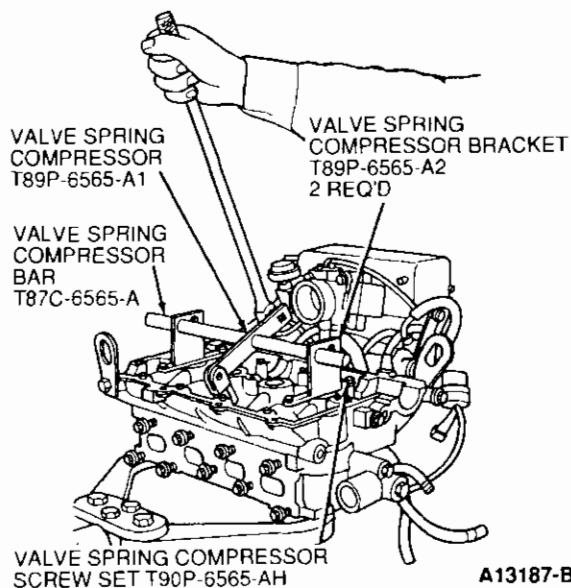

10. Remove valve stem seals using Valve Stem Seal Remover T89P-6510-D and Impact Slide Hammer T59L-100-B or equivalent.

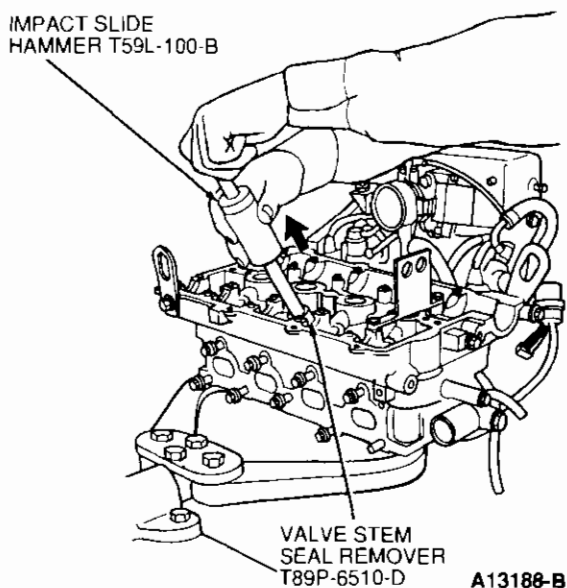

11. Tap out valve guides from combustion chamber side, using Valve Guide Remover / Replacer T89P-6510-A or equivalent.

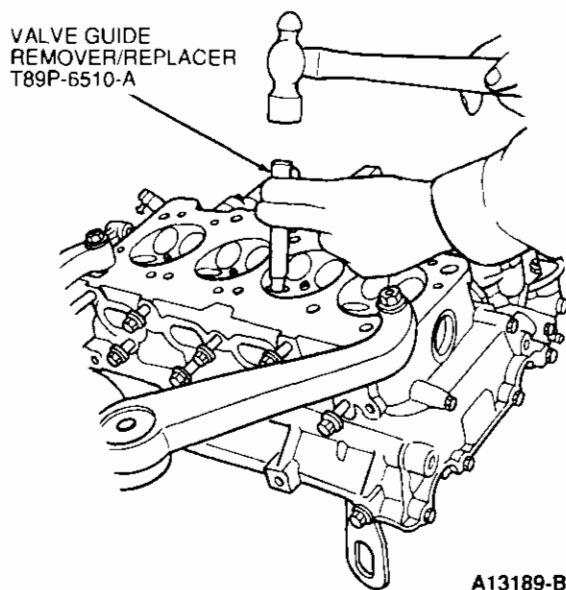

NOTE: For cylinder head service refer to Service Procedures as outlined.

## Assembly

1. Fit circlip onto valve guide, if required.
2. Install valve guides using Valve Guide Remover / Replacer T89P-6510-A or equivalent. Tap into head until exposed height is 16.8-17.4mm (0.661-0.685 inch).

**CAUTION: Tap lightly or circlip will be damaged and valve guide will not be secure in cylinder head.**

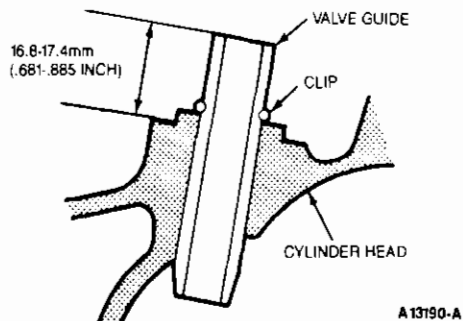

**DISASSEMBLY AND ASSEMBLY (Continued)**

NOTE: Although the shapes of the intake and exhaust valve guides are different, the exhaust valve guides are used on both sides as replacements.



INTAKE



EXHAUST

A13503-A

3. Lubricate valve stem seals with clean engine oil and install using Valve Stem Seal Replacer T90P-6510-AH or equivalent. Set seal into tool and tap lightly onto guide boss until seated.

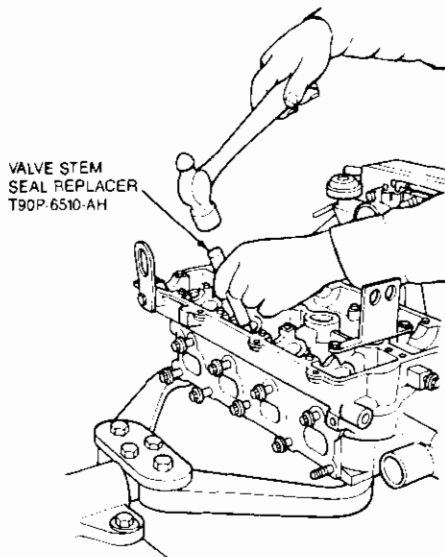
VALVE STEM  
SEAL REPLACER  
T90P-6510-AH

A13191-A

4. Install valves in their original locations, unless replacing with new valves.
5. Install valves, springs, spring seats and keepers under spring compressor tools outlined under Disassembly.

6. Install hydraulic lash adjusters into their original locations.
7. Install camshafts. Apply clean engine oil to bearing surfaces. Install camshaft oil seals.
8. Apply light amount of Silicone Gasket and Sealant E8AZ-19562-A (ESE-M4G195-B) or equivalent to front camshaft bearing caps.
9. Install camshaft bearing caps in their original locations. Tighten retaining bolts to 11-14 N·m (9-10 lb-ft) in sequence shown.

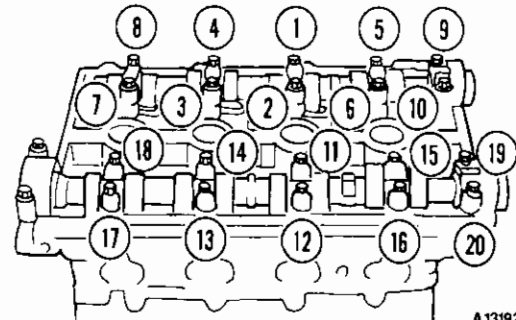

A13192-A

10. Install seal plate. Tighten retaining bolts to 8-11 N·m (7.1-9.7 lb-in).
11. Install distributor.
12. Install camshaft pulleys. Install intake cam with the "I" straight up and the exhaust cam with the "E" straight up. Hold camshaft with wrench to tighten camshaft retaining bolt. Tighten retaining bolt to 49-61 N·m (37-45 lb-ft).
13. Install spark plugs.

**Subassemblies****Piston and Connecting Rod****Disassembly**

1. Remove piston pin retaining clips.
2. Position piston and connecting assembly on Piston Pin Remover and Replacer D89L-6135-A or equivalent.

**DISASSEMBLY AND ASSEMBLY (Continued)**

3. Drive out piston pin.

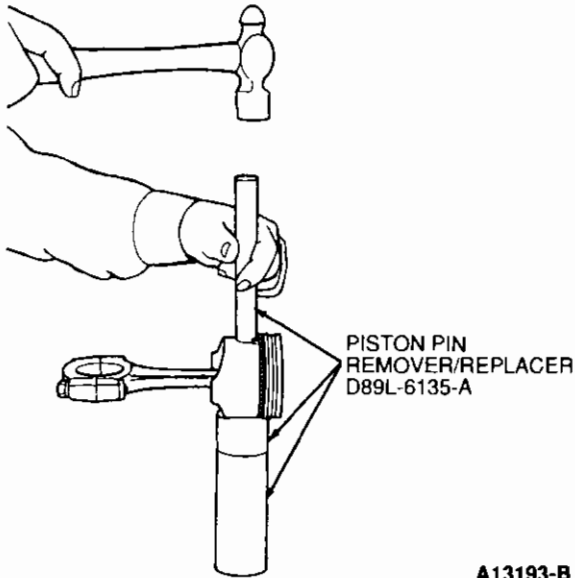

A13193-B

4. Remove piston rings using suitable piston ring remover.

NOTE: For piston connecting rod service, refer to Service Procedures as outlined.

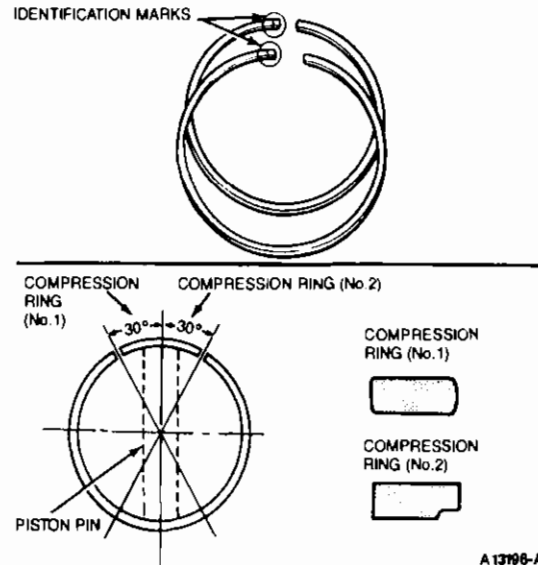

A13796-A

- Position piston and rod in Piston Pin Remover and Replacer D89L-6135-A or equivalent. Drive piston pin into piston. Install piston pin retaining clips.
- Ensure piston pivots freely on connecting rod.

**Oil Pump****Disassembly**

- Remove oil pump cover.
- Remove outer and inner rotors.
- Remove cotter pin and remove pressure piston, cap and spring.
- Remove oil seal if required using Locknut Pin Remover T78P-3504-N or equivalent.

**Assembly**

- Install piston rings as follows:
  - Install three piece oil control rings. Install the spacer ring first then the upper and lower rails. Position end gaps as shown.

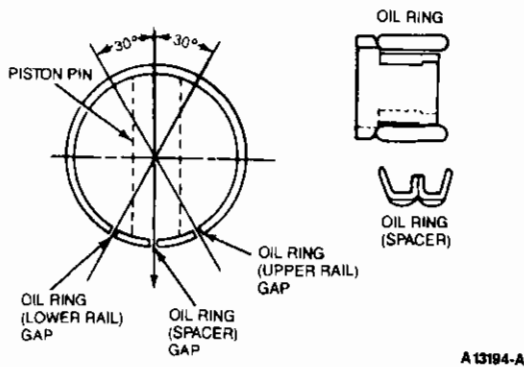

A13194-A

- Install second and top rings. Ensure the scraper faces downward on the second rings and the identification mark faces upward on both piston rings. Position end gaps as shown.

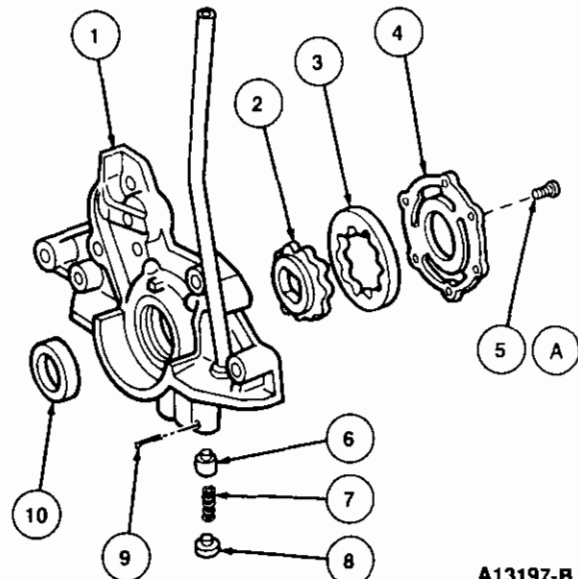

A13197-B



**DISASSEMBLY AND ASSEMBLY (Continued)**

Item	Part Number	Description
1	6600	Oil Pump Housing
2	—	Inner Rotor
3	—	Outer Rotor
4	—	Oil Pump Cover
5A	—	Screw (6 Req'd)
6	6674	Pressure Piston
7	—	Spring
8	6A616	Cap
9	9922-13035	Cotter Pin
10	6700	Front Crankshaft / Oil Pump Seal
A		Tighten to 19-25 N-m (14-18 Lb-Ft)

NOTE: For oil pump service, refer to Service Procedures as outlined.

**Assembly**

1. Install oil seal. Press into place until flush with pump body.

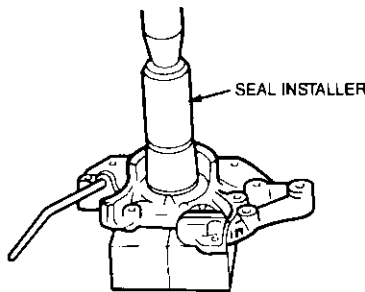

A13198-A

2. Install pressure piston, cap and spring with new cotter pin.
3. Install inner and outer rotors.
4. Install oil pump cover. Tighten screws to 19-25 N-m (14-18 lb-ft).

**Flywheel, Pilot Bearing**

**Removal**

Using a suitable driver, tap out bearing toward front (crankshaft side) of flywheel.

**Flywheel Bearing Removal**

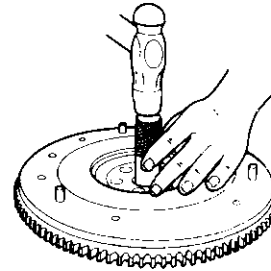

A13199-A

**Installation**

Using a suitable driver, tap new bearing into flywheel from clutch side of flywheel.

**Flywheel Bearing Installation**

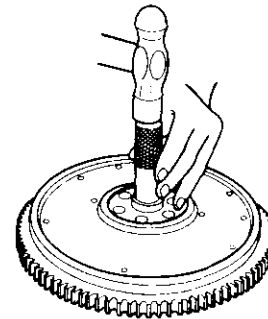

A13200-A

**SERVICE PROCEDURES**

**Service Limit Specifications**

Service limit specifications are intended to be a guide only, to be used when overhauling or reconditioning an engine or engine component. A determination can be made whether a component is suitable for continued service or should be replaced for extended service while the engine is disassembled.

**Cylinder Block**

**Cleaning**

After any cylinder bore service operation, such as honing or deglazing, clean the bore(s) with soap or detergent and water. Then, thoroughly rinse the bore(s) with clean water to remove the soap or detergent, and wipe the bore(s) dry with a clean, lint-free cloth. Finally, wipe the bore(s) with a clean cloth dipped in engine oil.

**CAUTION: If these procedures are not followed, rusting of the cylinder bore(s) may occur.**

## SERVICE PROCEDURES (Continued)

If the engine is disassembled, thoroughly clean the block with solvent. Remove old gasket material from all machined surfaces. Remove all pipe plugs that seal oil passages, clean out all the passages. Blow out all passages, then bolt holes, etc., with compressed air. Ensure threads in the cylinder head bolt holes are clean. Dirt in the threads may cause binding and result in a false torque reading. Use a tap to true-up threads and to remove all deposits. Thoroughly clean the grooves in the crankshaft bearings and bearing retainers.

### Inspection

After the block has been thoroughly cleaned, check it for cracks. Tiny cracks not visible to the naked eye may be detected by coating the suspected area with a mixture of 25 percent kerosene and 75 percent light engine oil. Wipe the part dry and immediately apply a coating of zinc oxide dissolved in wood alcohol. Do not use rubbing alcohol as a substitute. If cracks are present, the coating will become discolored at the damaged area. Replace the block if it is cracked.

Check all machined surfaces for burrs, nicks, scratches and scores. Remove minor imperfections with an oil stone.

Replace all plugs that show evidence of leakage. Inspect the cylinder walls for scoring, roughness or other signs of wear. Check the cylinder bore for out-of-round and taper. Measure the bore with an accurate bore gauge following the instructions of the manufacturer. Measure the diameter of each cylinder bore at the top, middle and bottom with the gauge placed at right angles and parallel to the centerline of the engine.

**NOTE:** Use only the measurements obtained at 90 degrees to the engine centerline when calculating the piston-to-cylinder bore clearance.

### Servicing Sand Holes or Porous Engine Castings

Porosity or sand hole(s), which will cause oil seepage or leakage, can occur with modern casting processes. A complete inspection of engine and transmission should be made. If the leak is attributed to the porous condition of the cylinder block or sand hole(s), service can be made with Ford Metallic Plastic C6AZ-19554-A (M3D35-A(E)) or equivalent.

**CAUTION: Do not service cracks with this material.**

Service with this metallic plastic must be confined to those cast iron engine component surfaces where the inner wall surface is not exposed to engine coolant pressure or oil pressure. For example:

1. Cylinder block surfaces extending along the length of the block, upward from the oil pan rail to the cylinder water jacket, but not including machined areas.
2. Lower rear face of the cylinder block.
3. Intake manifold casting. Service is not recommended to the intake manifold exhaust crossover section, since temperatures can exceed the recommended temperature limit of 260°C (500°F).

4. Cylinder front cover on engines using cast iron material.
5. Cylinder head, along the cylinder head cover gasket surface.

The following procedure should be used to service porous areas or sand holes in cast iron.

1. Clean surface to be serviced by grinding or rotary filing to a clean bright metal surface. Chamfer or undercut hole or porosity to a greater depth than rest of cleaned surface. Solid metal must surround hole. Openings larger than 6.35mm (1/4 inch) should not be serviced using metallic plastic. Openings in excess of 6.35mm (1/4 inch) can be drilled, tapped and plugged using common tools. Clean and service area thoroughly. Metallic plastic will not stick to a dirty or oily surface.
2. Mix metallic plastic base and hardener as directed on container. Stir thoroughly until uniform.
3. Apply service mixture with a suitable clean tool (putty knife, wood spoon, etc.) forcing epoxy into hole or porosity.
4. Allow service mixture to harden. This can be accomplished by two methods. Heat cure with a 250-watt lamp placed 254mm (10 inch) from serviced surface, or air-dry for 10-12 hours at temperatures above 10°C (50°F).
5. Sand or grind serviced area to blend with general contour of surrounding surface.
6. Paint the surface to match the rest of the block.

### Cylinder Block Flatness

1. Inspect the cylinder block for the following: Service or replace the cylinder block as necessary.
  - Leakage damage
  - Cracks
  - Scoring of cylinder wall
2. Measure flatness using Straight Edge D83L-4201-A or equivalent, on top surface of cylinder block in the six directions as illustrated.

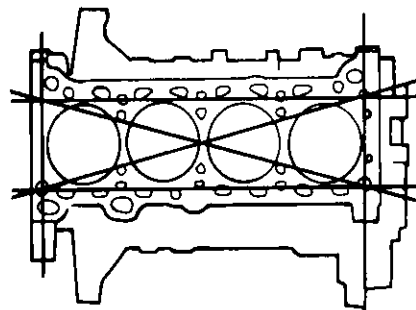

A1354-A

## SERVICE PROCEDURES (Continued)

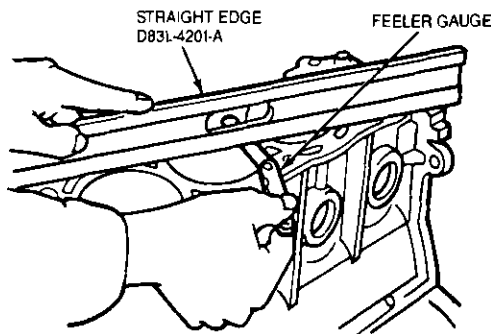

A13515-A

3. If the distortion exceeds 0.15mm (0.006 inch) MAX., service by machining or replace the cylinder block.

NOTE: Maximum machine limit for cylinder block is 0.20mm (0.008 inch).

### Cylinder Bores

#### Taper / Out-of-Round

1. Measure the cylinder bores in X and Y directions at three levels (A, B, and C) in each cylinder as illustrated. Compare measurement readings with specifications.

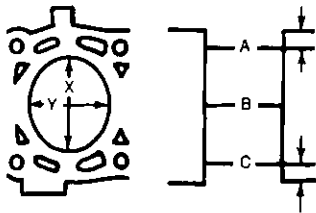

A13516-A

NOTE: If cylinder bore exceeds the maximum limit, refinish the cylinder to oversize.

2. If the difference between measurements A and C exceeds 0.019mm (0.0007 inch) taper, rebore the cylinder to oversize.
3. If the difference between measurements X and Y exceeds 0.019mm (0.0007 inch) out-of-round, rebore the cylinder to oversize.

**CAUTION:** The boring size should be based on the size of an oversize piston and be the same for all cylinders.

Honing is recommended for refinishing cylinder walls only when no crosshatch pattern is visible on cylinder walls, or for fitting pistons to the specified clearance. The grade of hone to be used is determined by the amount of metal to be removed. Follow the instructions of the hone manufacturer. If coarse stones are used to start the honing operation, leave enough material so that all hone marks can be removed with the finishing hone which is used to obtain the proper piston clearance. After honing, thoroughly clean cylinder bores with a detergent and water solution.

Cylinder walls that are severely marred and / or worn beyond the specified limits should be refinished.

**CAUTION:** Before any cylinder is refinished, all main bearing caps must be in place and tightened to the proper torque so that the crankshaft bearing bores will not become distorted from the refinishing operation.

If the cylinder will not clean up when refinished for the maximum oversize piston recommended, replace the block.

Refinish the cylinder to within approximately 0.038mm (0.0015 inch) of the required oversize diameter. This will allow enough stock for the final step of honing so that the correct surface finish and pattern are obtained. For the proper use of the refinishing equipment, follow the instructions of the manufacturer.

**CAUTION:** Only experienced personnel should perform this work.

Use a motor-driven, spring pressure-type Cylinder Hone Set T73L-6011-A or equivalent, hone at a speed of 300-500 rpm. Hones of grit sizes 180-220 will normally provide the desired bore surface finish of 18-38 AA.

When honing the cylinder bores, use a lubricant mixture of equal parts of kerosene and SAE No. 20 motor oil. Operate the hone in such a way as to produce a crosshatch finish on the cylinder bore. The cross-hatch pattern should be at an angle of approximately 30 degrees to the cylinder bore. After the final operation in either of the two refinishing methods described and prior to checking the piston fit, thoroughly clean with a detergent and water solution and then oil the cylinder walls. Mark the pistons to correspond to the cylinders in which they are to be installed. When the refinishing of all cylinders that require it has been completed and all pistons are fitted, thoroughly clean the entire block and oil the cylinder walls.

Refinish cylinders that are deeply scored, out-of-round, and / or taper exceeds specification. If the cylinder walls have minor surface imperfections, but the out-of-round and taper are within limits, it may be possible to remove the imperfections by honing the cylinder walls and installing new service piston rings, providing the piston clearance is within specification.

## SERVICE PROCEDURES (Continued)

### Ridge Reaming

If upper part of a cylinder wall shows uneven wear, remove the ridge with Cylinder Ridge Reamer T64L-6011-EA or equivalent.

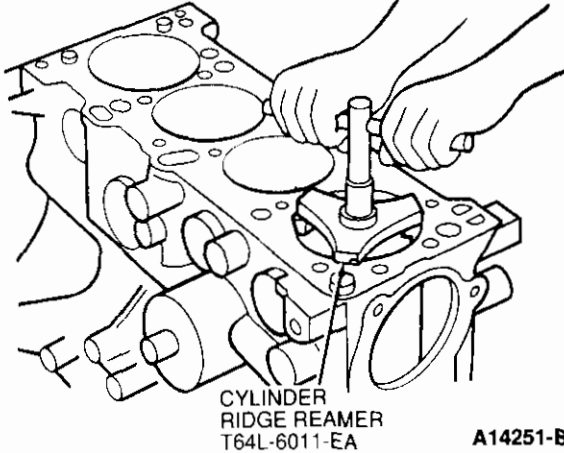

### Pistons, Piston Rings and Piston Pins

#### Pistons

Carefully inspect the pistons for fractures at the ring lands, skirts, oil ring slot corners, and pin bosses, and for scuffed, rough or scored skirts. Clean piston ring grooves using Piston Ring Groove Cleaner D81L-6002-D or equivalent. If the lower inner portion of the ring grooves have a high step, replace the piston. The step will interfere with ring operation and cause excessive ring side clearance.



Spongy, eroded areas near the edge of the top of the piston are usually caused by detonation or pre-ignition. A shiny surface of the thrust surface of the piston, offset from the centerline between the piston pin holes, can be caused by a bent connecting rod. Replace pistons that show signs of excessive wear, wavy ring lands, fractures or damage from detonation or pre-ignition.

**NOTE:** When replacing piston(s), piston rings must also be replaced.

1. Inspect outer surfaces of piston(s) for seizure or scoring. Replace piston(s) if required.
2. Measure the outer diameter of each piston at right angles to the piston pin. Make the measurement 16.5mm (0.650 inch) below the lowest oil ring groove bottom edge.

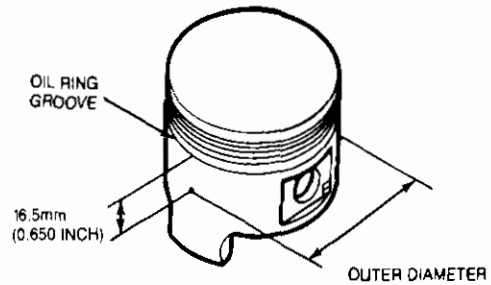

3. Measure the cylinder bore diameter as outlined under Cylinder Block Service Procedures. Calculate piston-to-cylinder clearance. If clearance exceeds the maximum specification, replace the pistons, and / or rebore the cylinder block as necessary.

#### Pistons and Piston Rings

1. Measure the piston ring-to-ring land clearance around entire piston circumference using a new piston ring and a feeler gauge. If the clearance exceeds maximum specification, replace the piston.

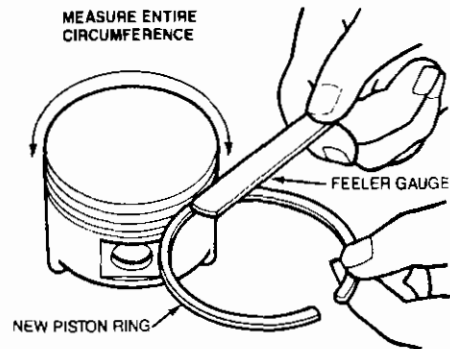

**SERVICE PROCEDURES (Continued)**

**Piston and Piston Pin**

1. Measure piston pin bore diameter in X and Y directions at four points as shown.

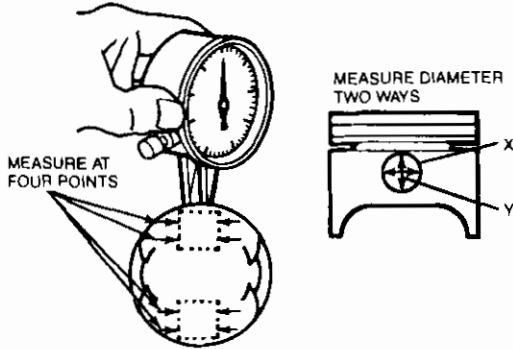

A14271-A

2. Measure piston pin diameter in X and Y directions at four points as shown.

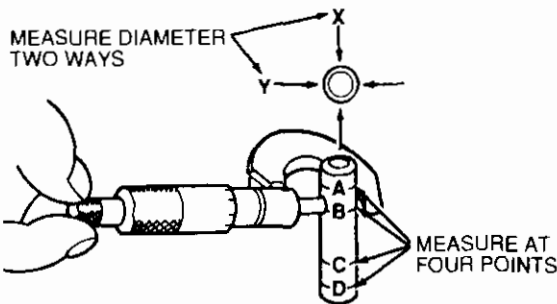

PIN DIAMETER: 19.987-19.993mm  
(0.7869-0.7871 INCH)

A14272-B

3. Calculate piston-to-pin clearance. If clearance exceeds 0.005-0.013mm (0.0002-0.0005 inch), replace piston and / or piston pin as required.

**Piston Rings**

1. Insert a new piston ring into cylinder bore. Use a piston and push the piston ring to the bottom of ring travel in the cylinder.

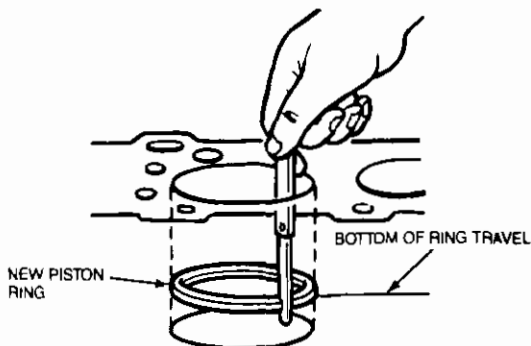

A14269-A

2. Measure piston ring end gap. Repeat measuring steps for all rings in each cylinder bore. Replace rings if gap exceeds maximum specification.

**Connecting Rod**

1. Measure each connecting rod bushing inner diameter in two directions.

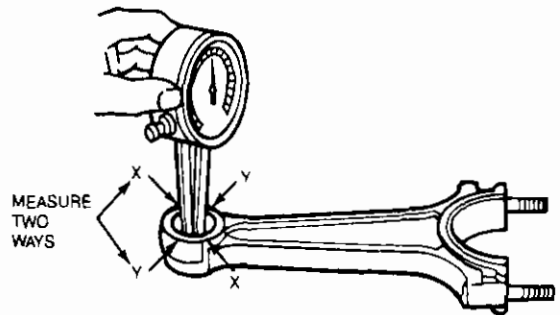

A14274-A

2. Measure piston pin diameter as outlined.
3. Calculate piston pin-to-connecting rod bushing clearance. Clearance should not exceed 0.010-0.027mm (0.0004-0.0011 inch).
4. Install connecting rod on a holding fixture for checking straightness. Maximum deviation should not exceed 0.198mm (0.0078 inch). If out of specification, replace connecting rod.

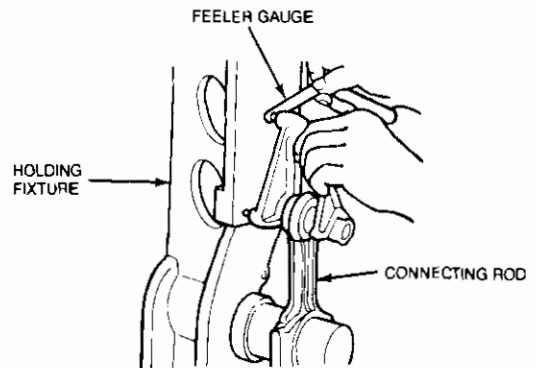

A14273-A

**Crankshaft**

1. Check crankshaft bearing and seal surfaces for damage and scoring. Inspect oil holes for clogging. Clean crankshaft in solvent, blow out all oil passages with air.

**SERVICE PROCEDURES (Continued)**

- Set crankshaft on V-blocks and measure runout at center journal using a dial indicator. If runout exceeds 0.04mm (0.0016 inch) replace crankshaft.

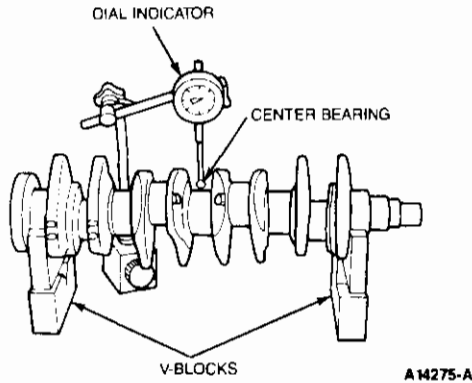

- Measure each crankpin and bearing journal in two directions. If diameters are less than minimum, machine journals to match on undersized bearing.

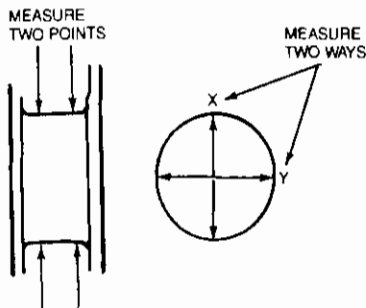

A14276-A

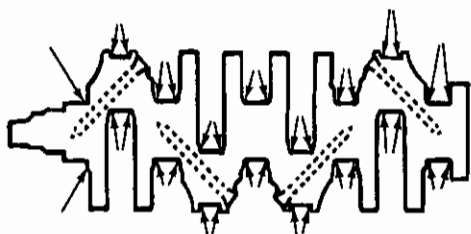

FILLET ROLL AREAS  
DIMENSION R: 1.5mm (0.06 INCH)

A14277-A

**CAUTION: Do not remove fillet area (dimension R) when machining the crankshaft.**

**NOTE:** Undersize bearings are available in the following dimensions:

- 0.25mm (0.010 inch)
- 0.50mm (0.020 inch)

**Crankshaft and Connecting Rod Bearings**

Bearings that are to be reused should be identified so they can be installed in their original locations.

Clean the bearing inserts and caps thoroughly in solvent, and dry them with compressed air.

**CAUTION: Do not scrape gum or varnish deposits from the bearing shells with a sharp tool.**

**Inspection**

Inspect each bearing carefully. Bearings that have a scored, chipped or worn surface should be replaced. Typical examples of unsatisfactory bearings and their causes are shown in the illustration. The copper lead bearing base may be visible through the bearing overlay. If the base showing is less than 20 percent of the total area, the bearing is not excessively worn. It is not necessary to replace the bearing if the bearing clearance is within recommended limits. Check the clearance of bearings that appear to be satisfactory with Plastigage as outlined.

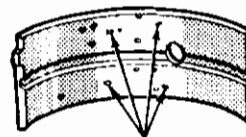

CRATERS OR POCKETS  
FATIGUE FAILURE

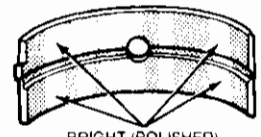

BRIGHT (POLISHED) SECTIONS  
IMPROPER SEATING

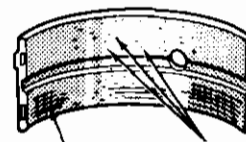

SCRATCHES  
DIRT IMBEDDED INTO BEARING MATERIAL  
SCRATCHED BY DIRT

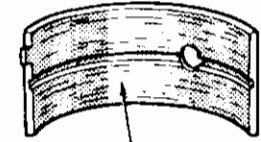

OVERLAY WIPED OUT  
LACK OF OIL OR IMPROPER CLEARANCE

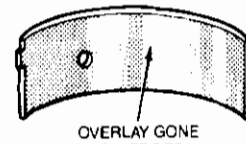

OVERLAY GONE FROM EDGES  
HOURGLASSING

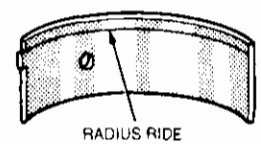

RADIUS RIDE

A14294-A

**SERVICE PROCEDURES (Continued)****Crankshaft Oil Clearance**

1. Install upper main bearings and thrust bearings in cylinder block.
2. Install crankshaft.
3. Position Plastigage at the high point of the journals.
4. Install lower main bearings and caps.
5. Tighten main bearing cap retaining bolts to 54-59 N·m (40-43 lb·ft) in sequence shown. Tighten in two or three steps.

**NOTE:** Do not rotate crankshaft while Plastigage is being used. A false reading or no reading will result.

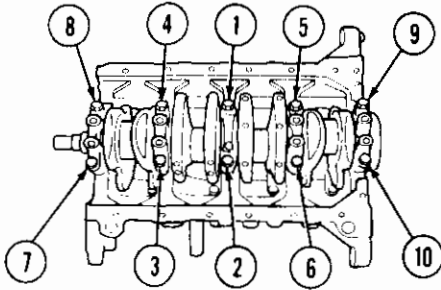

A14280-A

6. Remove bearing caps. Measure Plastigage using measuring guide. If clearance exceeds specification, the crankshaft must be machined and undersized bearings fitted.

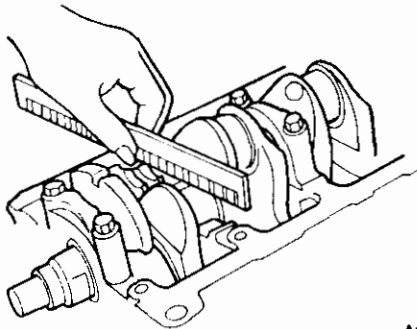

A14281-A

**Crankshaft End Play**

1. Apply clean engine oil to crankshaft main bearing journals and to main bearing surfaces.

2. Install crankshaft and thrust bearings. Tighten main bearing caps in sequence shown to 54-59 N·m (40-43 lb·ft). Tighten in two or three steps.

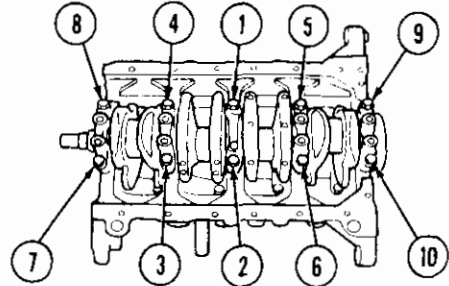

A14280-A

3. Using a dial indicator, measure end play by moving crankshaft fully forward to fully rearward. Repeat several times to ensure correct reading.
4. Crankshaft end play should be 0.080-0.282mm (0.0031-0.011 inch), not to exceed 0.30mm (0.0118 inch).

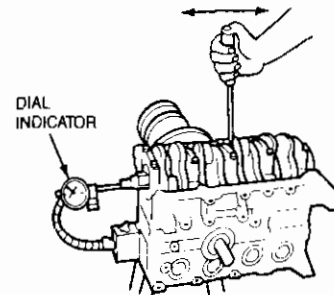

A14284-A

5. If end play exceeds maximum specification, machine crankshaft and install oversize thrust bearings, or replace crankshaft.

**Oil Pump**

1. Disassemble oil pump as outlined.
2. Thoroughly clean all parts.
3. Inspect pressure spring for weakness or breakage.

## SERVICE PROCEDURES (Continued)

4. Inspect pressure spring free length. Spring should measure 45.5mm (1.791 inch). Replace spring if required.

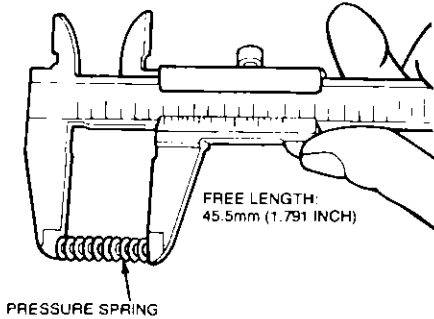

A14287-A

5. Measure inner to outer rotor clearance as shown. If measurement exceeds 0.20mm (0.0079 inch), replace rotors or oil pump.

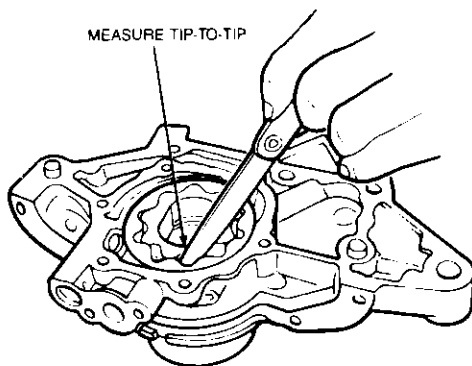

A14288-A

6. Measure outer rotor to pump body clearance. If measurement exceeds 0.22mm (0.0087 inch), replace rotors or pump.

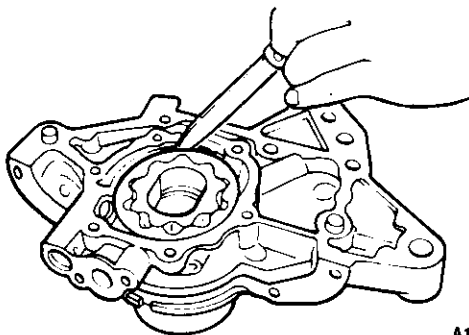

A14289-A

7. Measure rotor to pump cover clearance using a straight edge as shown. If measurement exceeds 0.14mm (0.0055 inch), replace rotors or pump.

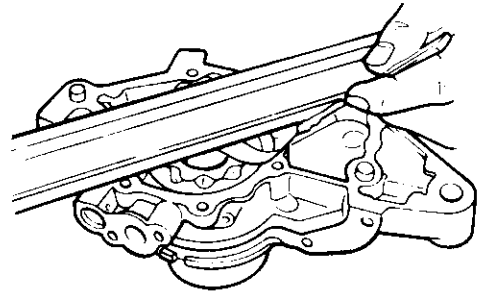

A14290-A

### Oil Jet

1. Push the check ball and verify that it moves smoothly.
2. Blow through the oil jet and verify that air flows.

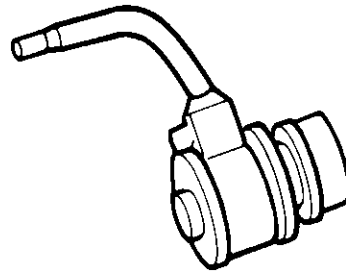

A14265-A

### Cylinder Head

Replace the head if it is cracked. Remove all burrs or scratches with an oil stone.

#### Cleaning

With the valves installed to protect the valve seats, remove deposits from the combustion chambers and valve heads with a scraper and a wire brush.

**CAUTION: Be careful not to damage the cylinder head gasket surface.**

After the valves are removed, clean the valve guide bores. Use cleaning solvent to remove dirt, grease and other deposits from the valves with a fine wire brush or buffing wheel.

#### Inspection

Inspect the cylinder heads for cracks or excessively burned areas in the exhaust outlet ports.

Check the cylinder head for cracks and inspect the gasket surface for burrs and nicks. Small imperfections of this type can be dressed down using an oil stone. Replace the head if it is cracked.



## SERVICE PROCEDURES (Continued)

The following inspection procedures are for a cylinder head that is to be completely overhauled. For individual service operations, use only the pertinent inspection procedure.

### Cylinder Head Flatness

1. Inspect the cylinder head for damage, cracks and leakage of water and oil. Replace the cylinder head if necessary.
2. Measure the cylinder head flatness using Straight Edge D83L-4201-A or equivalent in six directions as illustrated.

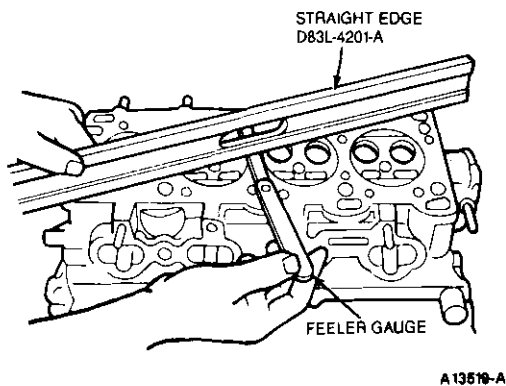
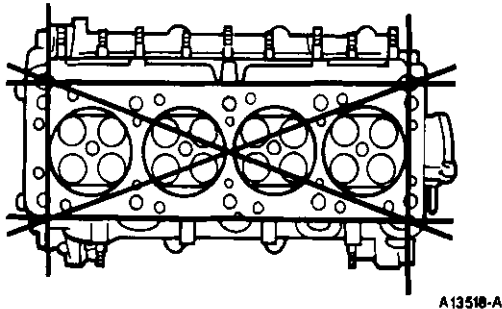

NOTE: Before machining the cylinder head, check the following and service or replace the cylinder head as necessary.

- Sinking of valve seats
- Damage of manifold contact surface
- Camshaft oil clearances and end play

3. If the cylinder head flatness exceeds 0.15mm (0.006 inch) machine the cylinder head surface.

NOTE: Maximum machine limit for cylinder head is 0.20mm (0.008 inch).

4. Measure the intake and exhaust manifold contact flatness in the four directions as illustrated.

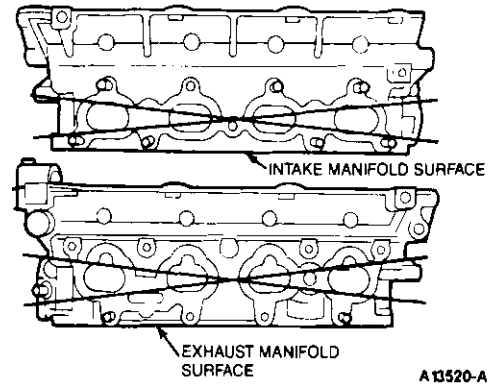

5. If distortion exceeds 0.15mm (0.006 inch), machine the surface or replace the cylinder head.

### Valve and Valve Guide

1. Inspect each valve for the following. Replace or resurface the valve as necessary.
  - a. Damaged or bent stem
  - b. Rough or damaged face
  - c. Damaged or unevenly worn stem tip
2. Measure the valve head margin thickness of each valve. Replace the valve if margin thickness is less than 0.5mm (0.020 inch).

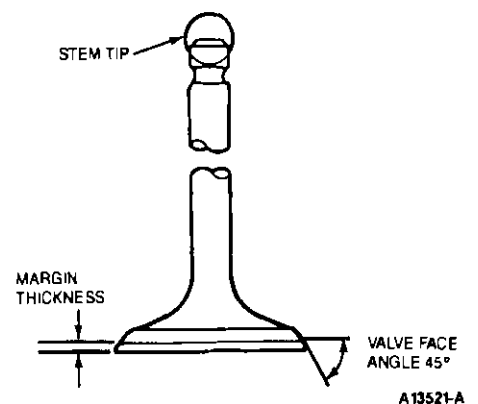

3. Measure the overall length of each valve. Refer to Specifications.

## SERVICE PROCEDURES (Continued)

4. Measure the stem diameter of each valve at points shown. Refer to Specifications.

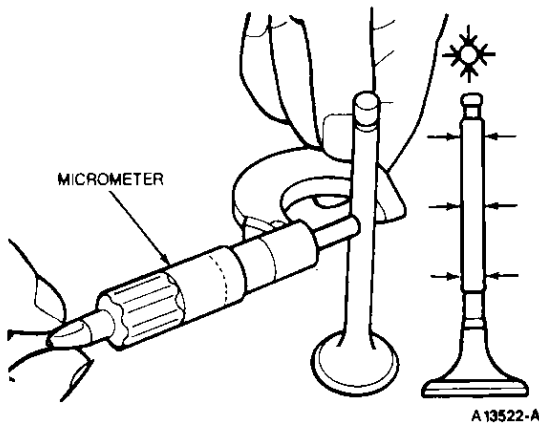

5. Measure the inner diameter of each valve guide at the points shown.

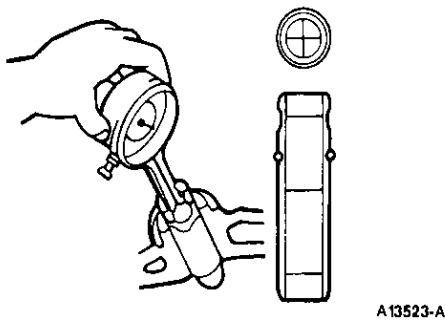

6. Calculate the valve stem to guide clearance. Subtract the outer diameter of the valve stem from the inner diameter of the corresponding valve guide.

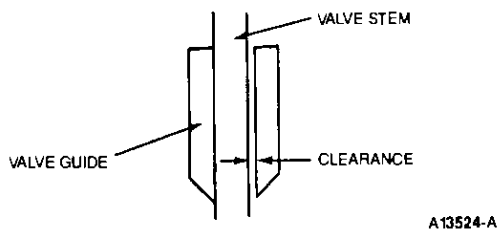

7. If the clearance exceeds specification, replace the valve and / or valve guide.
8. Measure the height of each valve guide. Replace the valve guide if necessary.

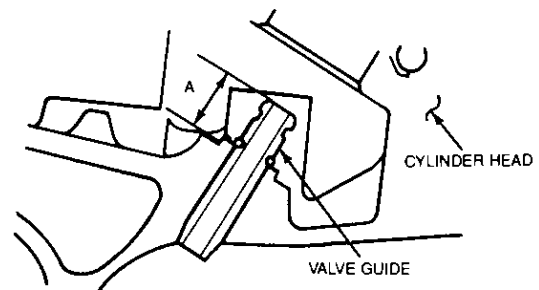

### Valve Seat

1. Inspect the contact surface of each valve seat and valve face for roughness and / or damage.
2. If necessary, resurface the valve seat with a 45 degree valve seat cutter and / or resurface the valve face.
3. Apply a thin coat of Prussian blue to the valve face.
4. Inspect the valve seating by pressing the valve against the seat.
 

If blue does not appear 360 degrees around the valve face, replace the valve.

If blue does not appear 360 degrees around the valve seat, resurface the seat.
5. Measure the seat contact width. Measurement must be 0.8-1.4mm (0.0315-0.0551 inch).

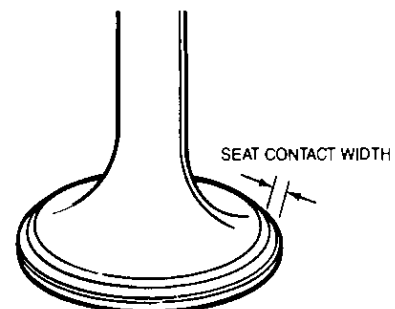

6. Verify that the valve seating position is at the center of the valve face.
- If the seating position is too high, correct the valve seat with a 70 degree cutter and a 45 degree cutter.

## SERVICE PROCEDURES (Continued)

If the seating position is too low, correct the intake valve seat with a 35 degree cutter and a 45 degree cutter. Correct the exhaust valve seat with a 15 degree cutter and a 45 degree cutter.

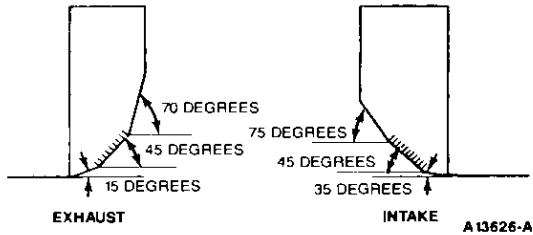

A13626-A

7. Seat the valve to the valve seat with lapping compound.
8. Measure the protruding length (dimension L in illustration) of the valve stem. Measurement should be 43.5mm (1.713 inch).

If measurement is 43.5-44.0mm (1.713-1.732 inch), no correction needed.

If measurement is 43.5-44.0mm (1.713-1.732 inch), adjust with washer on spring seat area of cylinder head.

If measurement is 45.0mm (1.772 inch) or more, replace cylinder head.

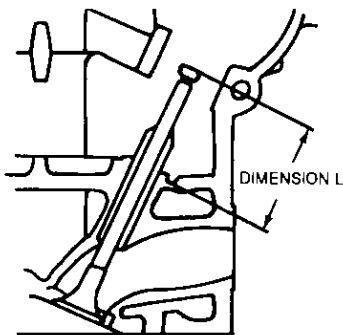

A14254-A

### Valve Spring

1. Inspect each valve spring for cracks or damage.
2. Measure the free length and out-of-square. Replace the valve spring if necessary.

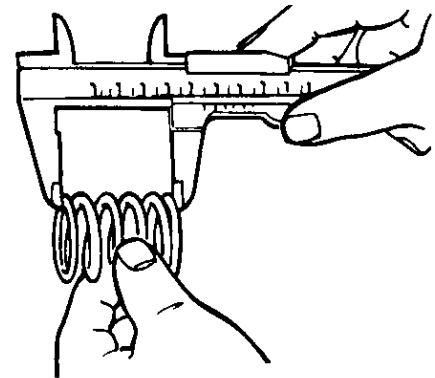

A14255-A

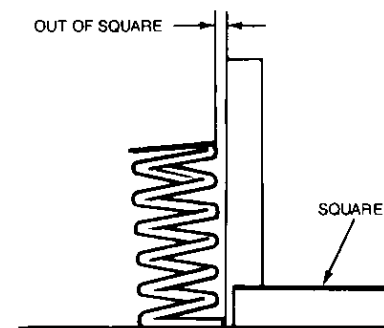

A14256-A

### Camshaft

1. Set the front and rear journals on V-blocks.
2. Measure the camshaft runout. If runout exceeds 0.03mm (0.0012 inch), replace camshaft.

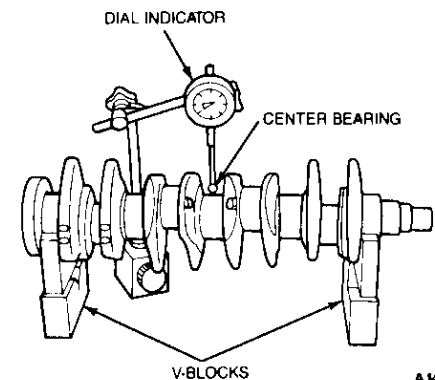

A14275-A

3. Inspect the camshaft for wear or damage. Replace the camshaft if necessary.

## SERVICE PROCEDURES (Continued)

4. Measure the cam lobe heights at the two points as shown. Replace camshaft if any measurement is below minimum specification.

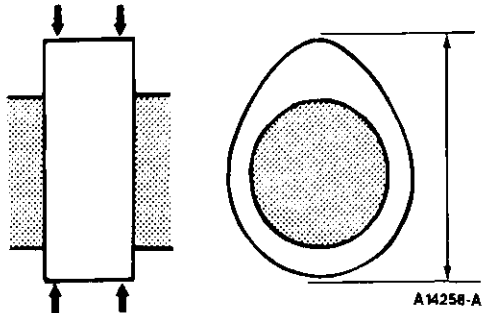

5. Measure the journal diameters in X and Y directions at the two points (A and B) shown. Replace camshaft if out-of-round exceeds specification.

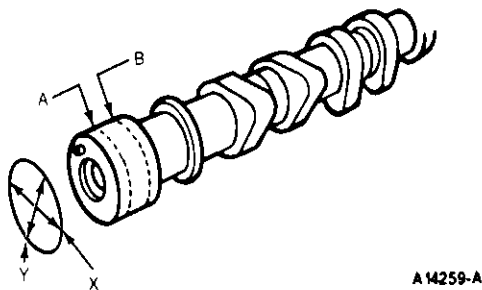

6. Measure the camshaft oil clearance as follows:  
NOTE: Do not install hydraulic lash adjuster (HLA) for this procedure.
- Remove all foreign material and oil from the journals and bearing surface.
  - Set the camshaft onto the cylinder head.
  - Position Plastigage atop the journals in the axial direction.
  - Install the camshaft caps according to the cap number and arrow mark.
  - Install cap retaining bolts. Tighten in sequence shown to 11-14 N·m (9-10 lb-ft). Tighten in two steps.

## CAMSHAFT TIGHTENING SEQUENCE

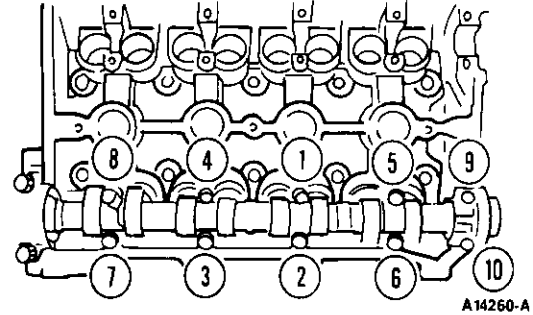

- f. Loosen bearing cap bolts in two or three steps in sequence shown.

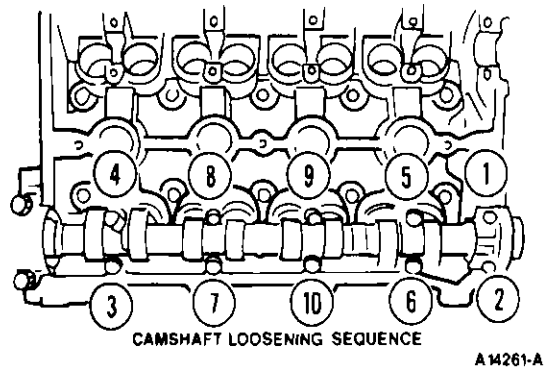

- g. Remove caps and measure Plastigage. This will give the oil clearance. If measurement exceeds 0.15mm (0.006 inch), replace cylinder head.

## PLASTIGAGE GUIDE

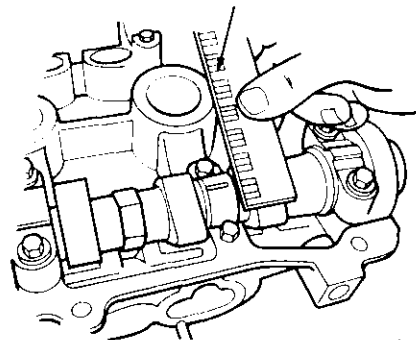

**SERVICE PROCEDURES (Continued)**

- h. Using Dial Indicator with Bracketry TOOL-4201-C or equivalent, measure camshaft end play. Camshaft should set in cylinder head without HLA or bearing caps installed. If end play exceeds 0.20mm (0.008 inch), replace the camshaft and/or the cylinder head.

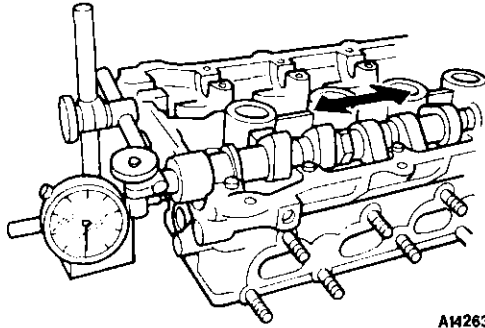

AH263-A

**Hydraulic Lash Adjusters (HLA)**

**CAUTION:** Do not attempt to service the HLA.

1. Inspect the HLA friction surfaces for wear or damage. Replace the HLA if necessary.
2. Hold the bucket body and press the plunger by hand. If the plunger moves, replace the HLA.

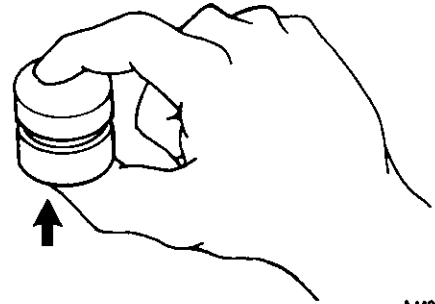

AH264-A

## SPECIFICATIONS

GENERAL SPECIFICATIONS	CYLINDER BLOCK
DISPLACEMENT ..... 1597cc (97.4 cu. inch)	HEIGHT ..... 206.5mm (8.130 inch)
NUMBER OF CYLINDERS ..... 4	Cylinder Head Flatness Maximum Limit ..... 0.15mm (0.006 inch)
BORE AND STROKE	Maximum Resurface Grinding ..... 0.20mm (0.008 inch)
Bore ..... 78mm (3.07 inch)	CYLINDER BORE DIAMETER : 78.000-78.019mm (3.0709-3.0717 inch)
Stroke ..... 83.6mm (3.29 inch)	SERVICE LIMIT
FIRING ORDER ..... 1-3-4-2	Standard Size ..... 78.000-78.019 (3.0709-3.0717)
	0.25 (0.010) Oversize ..... 78.250-78.269 (3.0807-3.0815)
	0.50 (0.020) Oversize ..... 78.500-78.519 (3.0905-3.0913)
	Taper ..... 0.019mm (0.0007 inch)
	Out-of-Round ..... 0.019mm (0.0009 inch)
CYLINDER HEAD AND VALVE TRAIN	CRANKSHAFT
COMBUSTION CHAMBER DESIGN ..... PENT-ROOF	MAIN BEARING JOURNAL DIAMETER ..... 49.938-49.956mm
VALVE GUIDE HEIGHT ..... 16.8-17.4mm (0.661-0.685 inch)	(1.9661-1.9668)
VALVE GUIDE BORE DIAMETER	0.25 (0.010) Standard ..... 49.688-49.706 (1.9562-1.9569)
Intake and Exhaust ..... 6.01-6.03mm (0.2366-0.2374 inch)	Undersize Minimum ..... 49.64 (1.954)
VALVE SEATS	0.50 (0.020) Standard ..... 49.438-49.456 (1.9464-1.9471)
Width	Undersize Minimum ..... 49.39 (1.944)
Intake ..... 0.8-1.4mm (0.0315-0.0551 inch)	Maximum Out-of-Round ..... 0.05mm (0.0019 inch)
Exhaust ..... 0.8-1.4mm (0.0315-0.0551 inch)	Maximum Taper ..... 0.05mm (0.0019 inch)
Angle ..... 45°	CONNECTING ROD JOURNAL DIAMETER ..... 44.940-44.956mm
VALVE STEM TO GUIDE CLEARANCE	(1.7693-1.7699 inch)
Intake ..... 0.025-0.060mm (0.0010-0.0024 inch)	CRANKPIN DIAMETER
Exhaust ..... 0.30-0.65mm (0.0012-0.0026 inch)	Standard Size
VALVE HEAD DIAMETER	Standard ..... 44.940-44.956 (1.7693-1.7699)
Intake ..... 30.9-31.1mm (1.217-1.224 inch)	Minimum ..... 44.89 (1.767)
Exhaust ..... 26.1-26.3mm (1.028-1.035 inch)	0.25 (0.010) Undersize
VALVE FACE ANGLE ..... 45°	Standard ..... 44.690-44.706 (1.7594-1.7601)
VALVE MARGIN	Minimum ..... 44.64 (1.757)
Thickness-Minimum	0.50 (0.020) Undersize
Intake ..... 0.5mm (0.020 inch)	Standard ..... 44.440-44.456 (1.7496-1.7502)
Exhaust ..... 0.5mm (0.020 inch)	Minimum ..... 44.39 (1.748)
VALVE LENGTH	Maximum Out-of-Round ..... 0.05mm (0.0020 inch)
Intake ..... 105.29mm (4.1452 inch)	Maximum Taper ..... 0.05mm (0.0020 inch)
Minimum ..... 104.8mm (4.126 inch)	CRANKSHAFT RUNOUT-MAXIMUM ..... 0.04mm (0.0016 inch)
Exhaust ..... 105.39mm (4.1492 inch)	MAIN BEARINGS
Minimum ..... 104.9mm (4.130 inch)	Oil Clearance ..... 0.024-0.042mm (0.0010-0.0017 inch)
VALVE STEM DIAMETER	Maximum ..... 0.08mm (0.0031 inch)
Intake ..... 5.970-5.985mm (0.2350-0.2356 inch)	Undersize ..... 0.25mm (0.010 inch) 0.50mm (0.020 inch)
Exhaust ..... 5.965-5.980mm (0.2348-0.2354 inch)	CONNECTING ROD BEARINGS
VALVE SPRINGS	Oil Clearance ..... 0.028-0.068mm (0.0011-0.0027 inch)
Free Length ..... 47.2mm (1.858 inch)	Maximum ..... 0.10mm (0.0039 inch)
Minimum ..... 45.8mm (1.803 inch)	THRUST BEARING
Out of Square-Maximum ..... 1.6mm (0.063 inch)	Width
Settling Load/Height ..... 196 N/40mm (44 lb/1.54 inch)	Standard ..... 2.500-2.550mm (0.984-0.1004 inch)
VALVE HLA BORE CLEARANCE	End Play ..... 0.080-0.282mm (0.0031-0.011 inch)
Intake ..... 0.025-0.066mm (0.0010-0.0026 inch)	Maximum ..... 0.30mm (0.0118 inch)
Exhaust ..... 0.025-0.066mm (0.0010-0.0026 inch)	
CAMSHAFT	CONNECTING ROD
Journal Diameter ..... 25.940-25.965mm (1.0213-1.0222 inch)	CONNECTING ROD
Out-of-Round Maximum ..... 0.05mm (0.002 inch)	Piston Pin Bore Diameter ..... 20.003-20.014mm
LOBE LIFT	(0.7875-0.7880 inch)
Intake ..... 40.888mm (1.6098 inch)	Crankshaft Bearing Bore Diameter ..... 48.000-48.016mm
Minimum ..... 40.688mm (1.6019 inch)	(1.8898-1.8904 inch)
Exhaust ..... 40.888mm (1.6098 inch)	Length (Center-to-Center) ..... 132.85-132.95mm
Minimum ..... 40.688mm (1.6019 inch)	(5.230-5.234 inch)
Wear Limit ..... 40.489mm (1.5940 inch)	ALIGNMENT (BORE-TO-BORE MAX. DIFF)
RUNOUT ..... 0.03mm (0.0012 inch)	Bending ..... 0.198mm (0.0078 inch)
ENDPLAY ..... 0.07-0.19mm (0.0028-0.0075 inch)	SIDE CLEARANCE (ASSEMBLED TO CRANK)
Maximum ..... 0.2mm (0.008 inch)	Standard ..... 0.110-0.262mm (0.0043-0.0103 inch)
Bearing Oil Clearance ..... 0.035-0.081mm (0.0014-0.0032 inch)	Maximum ..... 0.30mm (0.012 inch)
Maximum ..... 0.15mm (0.0059 inch)	

CA13507-B

## SPECIFICATIONS (Continued)

PISTONS	
DIAMETER	.77-954-77.974mm (3.0690-3.0698 inch)
0.25 (0.010) Oversize	.78.204-78.224 (3.0789-3.0797)
0.50 (0.020) Oversize	.78.454-78.474 (3.0887-3.0895)
PISTON-TO-BORE CLEARANCE	0.026-0.065mm (.0010-.0026 inch)
Maximum	0.15mm (.0059 inch)
PISTON RING GROOVE WIDTH	
Thickness	
Top	1.520-1.535mm (.0598-.0604 inch)
Second	1.520-1.535mm (.0598-.0604 inch)
Oil	4.120-4.040mm (.1583-.1591 inch)
PISTON RINGS	
Thickness	
Top	1.471-1.49mm (.0579-.0587 inch)
Second	1.471-1.49mm (.0579-.0587 inch)
Oil	4.015-4.035mm (.1580-.1588 inch)
Ring Gap	
Top	0.20-0.40mm (.008-.0157 inch)
Second	0.15-0.30mm (.0059-.0118 inch)
Oil	0.20-0.70mm (.008-.028 inch)
Side Clearance Limit	
Top	0.030-0.065mm (.0012-.0026 inch)
Second	0.030-0.065mm (.0012-.0026 inch)

PISTONS — (Continued)	
Oil	0.030-0.065mm (.0012-.0026 inch)
Maximum	0.15mm (.0059 inch)
PISTON PIN	
Diameter	19.987-19.993mm (.7869-.7871 inch)
Interference Fit	0.010-0.027mm (.0004-.0012 inch)
LUBRICATION SYSTEM	
OIL PUMP TYPE	Trochoid Gear
Regulating Pressure at 1,000 RPM	177-216 kPa (25-31 psi)
Regulating Pressure at 3,000 RPM	294-333 kPa (43-48 psi)
ROTOR CLEARANCE	
Inner Rotor Tooth Tip to Outer Rotor	0.02-0.16mm (.0008-.0063 inch)
Maximum	0.2mm (.0078 inch)
Outer Rotor to Body	0.09-0.18mm (.0035-.0071 inch)
Maximum	0.22mm (.0087 inch)
Side Clearance	0.03-0.11mm (.0012-.0043 inch)
OIL CAPACITY	
Total (Dry Engine)	3.6L (3.8 U.S. Quart)
Oil Pan	3.2L (3.4 U.S. Quart)
Oil Filter (Regular Size)	0.3L (.32 U.S. Quart)

CA13508-B

Description	N-m	Lb-Ft	Description	N-m	Lb-Ft
Shift Linkage Rod—Nut	16-22	12-16	RH Engine Mount Body Bracket—Bolt (1)	67-91	50-67
Shifter Stabilizer—Nut	31-46	23-34	RH Engine Mount Through Bolt	45-65	34-47
Engine End Plate—Screw	8-11	71-97 (Lb-In)	Front Engine Mount to Transmission—Bolt	37-52	28-38
Flywheel—Bolt	96-103	71-76	Front Engine Mount—Nut	64-89	48-65
Clutch Pressure Plate—Bolt	18-26	14-19	Rear Engine Mount—Bolt	37-52	28-38
Torque Converter—Bolt	34-49	25-36	Rear Engine Mount—Nut	32-47	24-34
Intermediate Axle Shaft Bearing Support—Bolt	37-52	28-38	Exhaust Manifold—Nut	39-57	29-42
Manual Transaxle to Engine—Bolt (Upper)	89-117	66-86	Intake Manifold—Nut	19-25	14-18
Manual Transaxle Engine—Bolt (Lower)	37-52	28-38	Intake Manifold—Bolt	19-25	14-18
Automatic Transaxle to Engine—Bolt (Upper)	55-80	41-59	Cylinder Head—Bolt <sup>1</sup>	76-81	56-59
Torque Converter Cover Plate—Bolt	7-10	62-88 (Lb-In)	Cylinder Head Cover—Bolt	8-11	71-97 (Lb-In)
Gusset Plate—Bolt	37-52	28-38	Timing Belt Tension Pulley—Bolt	37-52	28-38
Starter—Bolt	31-46	23-34	Timing Belt Idler Pulley—Bolt	37-52	28-38
Support Bracket, Intake Manifold—Bolt	31-46	23-34	Timing Belt Covers—Bolt	8-11	71-97 (Lb-In)
Starter Bracket to Support Bracket—Bolt	19-25	14-18	Seal Plate—Bolt	8-11	71-97 (Lb-In)
Shift Cable Pivot (Automatic)—Nut	44-64	33-47	Camshaft Pulley	49-61	37-45
Shift Cable Retaining Bolt (Automatic)	8-11	71-97 (Lb-In)	Crankshaft Main Bearing—Bolt	54-59	40-43

(Continued)

<sup>1</sup> Tighten first to 20-34 N-m (15-25 lb-ft), in sequence, then 76-81 N-m (56-59 lb-ft).

## SPECIFICATIONS (Continued)

Description	N-m	Lb-Ft	Description	N-m	Lb-Ft
Front Exhaust Pipe to Support Bracket—Bolt	43-61	32-45	Connecting Rod Bearing—Nut	47-52	35-38
Exhaust Pipe to Manifold—Nut (Naturally Aspirated)	31-46	23-33	Crankshaft Timing Pulley—Bolt	108-118	80-87
Exhaust Pipe to Manifold (Turbocharged)	24-32	18-23	Crankshaft Rear Seal Flange—Bolt	8-11	71-97 (Lb-In)
Chassis Cross Brace—Bolt	35-50	26-36	Crankshaft Pulley—Bolt	12-17	10-12
A-Arm Front Bolt	97-117	72-86	Oil Pan—Bolt	8-11	71-97 (Lb-In)
Wheel Lug Nuts	90-120	67-88	Oil Pump Assembly—Bolt	19-25	14-18
Ball Joint—Bolt	43-54	32-40	Oil Pump Pick-Up—Bolt	8-11	71-97 (Lb-In)
A/C Compressor—Bolt	39-54	29-40	Oil Pump Cover	19-25	14-18
Power Steering Pump Bracket—Nut	47-66	35-48	Camshaft Bearing—Bolt	11-14	9-10
Power Steering Pump Bracket—Bolt	47-66	35-48	Oil Spray Nozzle—Bolt	12-18	10-13
Power Steering—Adjusting Nut	37-52	28-38	Oil Pressure Sensor	12-18	10-13
Power Steering—Pivot Bolt	31-46	23-24	Knock Sensor	20-34	15-25
Radiator Bracket—Bolt	8-11	71-97 (Lb-In)	Oil Cooler—Nut	29-39	22-28
RH Engine Mount Body Bracket—Bolt (3)	20-28	15-20	Water Pump, Outlet Bolt	19-25	14-18
Hood Hinge Bolt	20-28	15-20	Water Pump Pulley Bolt	8-11	71-97 (Lb-In)

## SPECIAL SERVICE TOOLS

Tool Number	Description
T78P-3504-N	Locknut Pin Remover
T90P-6256-AH	Cam Seal Protector
T90P-6256-BH	Cam Seal Replacer
T89P-6565-A1	Valve Spring Compressor
T87C-6565-A	Valve Spring Compressor Pivot Bar
T89P-6565-A2	Valve Spring Compressor Brackets
T90P-6565-AH	Valve Spring Compressor Screw Set
T89P-6510-D	Valve Stem Seal Remover
T89P-6510-AH	Valve Stem Seal Replacer
D81L-6002-C	Piston Ring Compressor
T64L-6011-EA	Cylinder Ridge Reamer
T87C-6019-A	Front Seal Installer
T87C-6701-A	Seal Replacer

(Continued)

Tool Number	Description
T59L-1001-B	Impact Slide Hammer
D90P-6135-A	Piston Pin Remover and Replacer
T89P-6510-A	Valve Guide Remover / Replacer
D83L-4201-A	Straight Edge
T73L-6011-A	Cylinder Hone Set
TOOL-4201-C	Dial Indicator With Bracketry
D81L-6002-D	Piston Ring Groove Cleaner
T50T-100-A	Impact Slide Hammer

**ROTUNDA EQUIPMENT**

Model	Description
077-00043	Portable Crane
014-00705	Engine Cylinder Air Pressurization Kit