

# GROUP

# 05

(4000)

# DRIVELINE

## SECTION 05-04 Halfshafts, Front Drive

SUBJECT	PAGE	SUBJECT	PAGE
<b>DESCRIPTION</b>		<b>DISASSEMBLY AND ASSEMBLY (Cont'd.)</b>	
Halfshaft Handling .....	05-04-4	Rzeppa CV Joint .....	05-04-12
Hoisting.....	05-04-5	Tripot Joint.....	05-04-18
Towing .....	05-04-5	<b>REMOVAL AND INSTALLATION</b>	
Undercoating and Rustproofing .....	05-04-5	Halfshaft.....	05-04-7
Wheel and Tire Balancing.....	05-04-5	<b>SPECIAL SERVICE TOOLS</b> .....	05-04-21
<b>DIAGNOSIS</b> .....	05-04-5	<b>SPECIFICATIONS</b> .....	05-04-21
<b>DISASSEMBLY AND ASSEMBLY</b>		<b>VEHICLE APPLICATION</b> .....	05-04-1
Jointshaft.....	05-04-10		

### VEHICLE APPLICATION

Capri.

### DESCRIPTION

The halfshafts are the mechanical link that transfers engine torque from the transaxle and differential to the front wheels. At the transaxle end, the halfshafts are splined to the differential side gears. Disengagement of the shaft from the gear is prevented by an expanding spring steel circlip. During installation, the circlip compresses around the shaft as it enters the gear. Once through the differential gear, the circlip expands into a counterbore machined into the back side of the gear. The wheel end of the halfshafts are splined to the wheel hubs which are supported on opposed tapered wheel bearings. Disengagement of the shaft from the wheel hub is prevented by a washer and a staked locknut. Backlash between the wheel hub and halfshaft is eliminated by the splines. The wheel hub splines are machined straight while the halfshaft splines are machined with a slight helical cut. The difference in splines provides a tight backlash free coupling without the removal and installation problems associated with an interference fit.

Constant velocity joints are installed at both ends of the halfshafts. Three different types of CV joints are used. All outboard CV joints are the Birfield-type. When the vehicle is equipped with an automatic transaxle, the inboard CV joints are the tripot type. A vehicle equipped with a manual transaxle will have Rzeppa or double offset inboard CV joints. The tripot joints are used with the automatic transaxle to prevent the transfer of engine vibration through the halfshafts to the vehicle body. Additional reduction of vibration is provided by a dynamic damper installed approximately in the middle of the right halfshaft (on naturally aspirated vehicles).

The constant velocity joints are necessary because the halfshaft is required to transmit torque while compensating for front suspension movement. As the suspension moves, the CV joints allow the halfshaft to change length and to operate smoothly through varying angles. For the necessary flexibility, the Rzeppa and Birfield-type CV joints use ball bearings positioned by a cage. The tripot joint uses three balls mounted on needle bearings and a spider. In both types of joints, the outer race is machined into the CV joint housing.

**DESCRIPTION (Continued)**

The Rzeppa and tripod CV joints can be disassembled and serviced. Other than the CV joint boot, the outboard Birfield CV joint is serviced only as an assembly with the shaft.

To prevent torsional vibration and torque steer on turbocharged vehicles, drive to the RH front wheel is through a joint (intermediate) shaft and a conventional halfshaft. Both shafts are of similar length and are supported by a bearing enclosed in housing which is bolted to the engine.

DESCRIPTION (Continued)

Halfshafts, Naturally Aspirated Vehicles

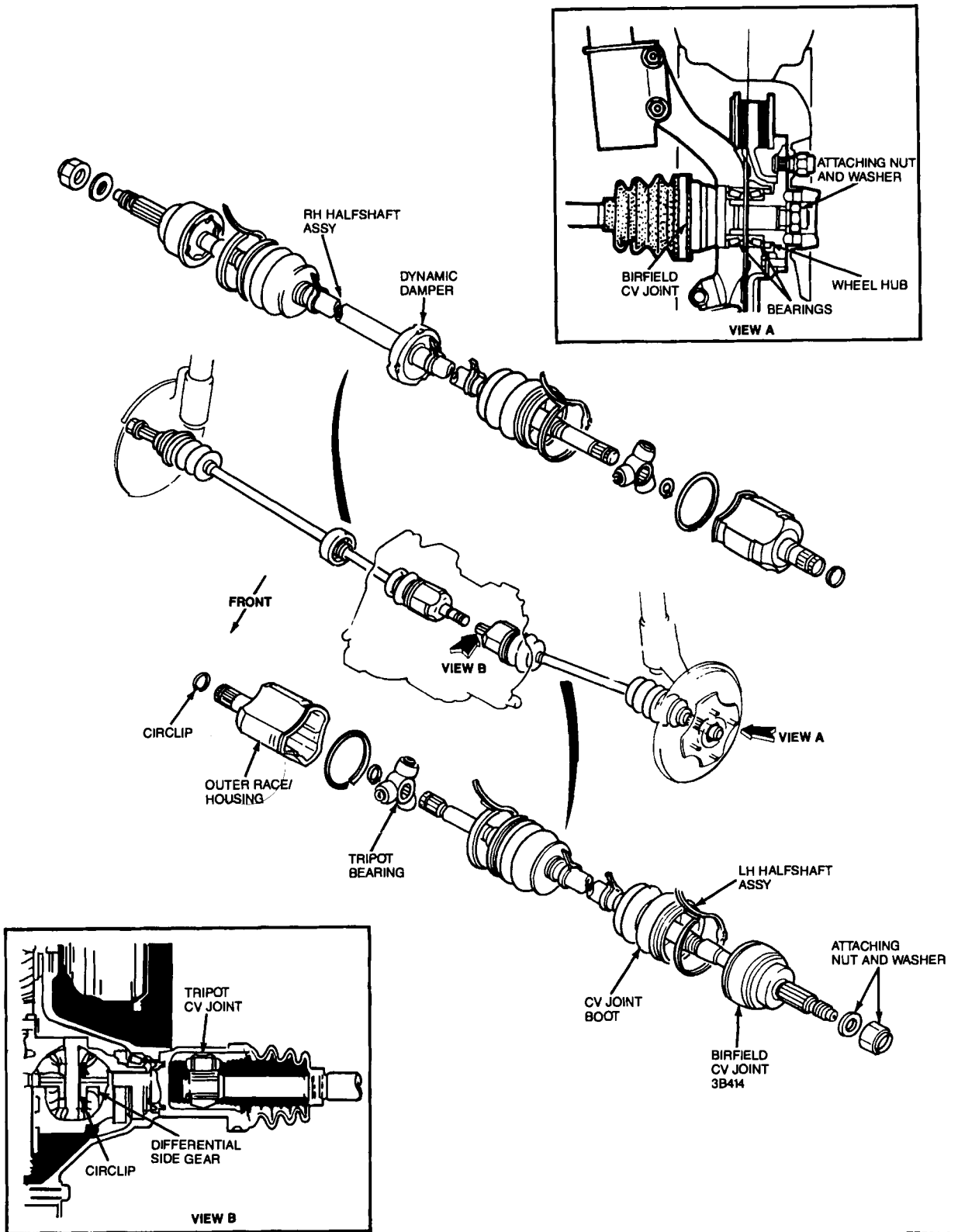

E7561-A

## DESCRIPTION (Continued)

## Halfshafts, Turbocharged Vehicles

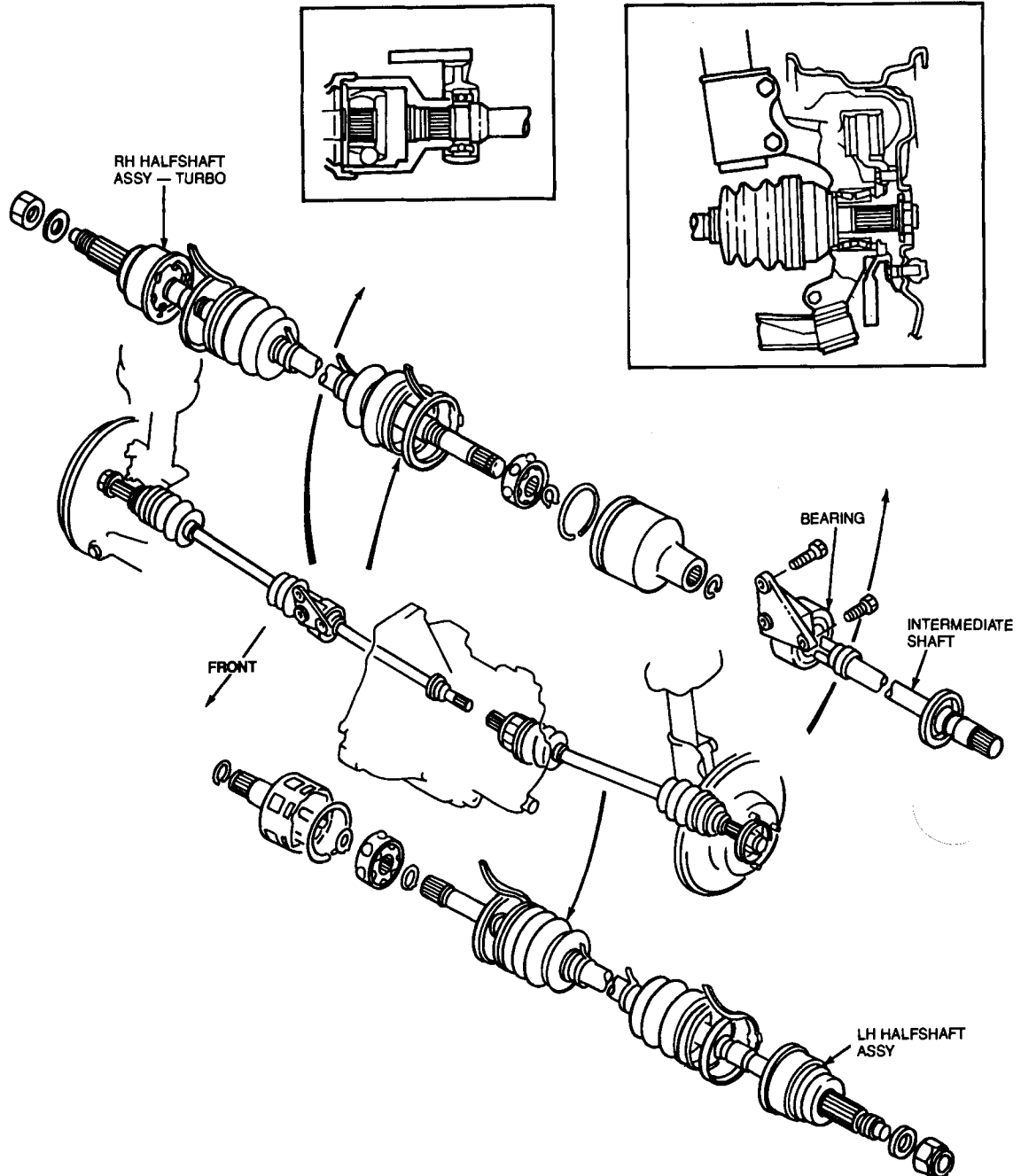

E7540-A

**Halfshaft Handling**

Care must be exercised during the halfshaft removal, installation, disassembly and assembly procedures outlined in this Section. Some general guidelines intended to minimize unnecessary damage to a halfshaft are outlined below:

- Do not over-angle a CV joint beyond its capacity. The CV joint can take axial and angular movement of approximately 20 degrees in any direction. Beyond 20 degrees damage to the joint will occur.

**DESCRIPTION (Continued)**

- If the halfshaft is disconnected either from the differential or the wheel hub, do not allow the halfshaft to hang from the CV joint. Provide support by wiring the shaft to a convenient underbody component.
- An installed halfshaft must not be used as a fulcrum point when attempting to position another component with a pry bar.
- Do not allow the CV joint boot to contact sharp edges or hot engine and exhaust components.
- Never strike a halfshaft component with a metallic hammer.
- Do not drop an assembled halfshaft. The impact may damage internal components or cut the CV joint boot. The boot can be cut from the inside without immediate external evidence of the damage.
- During disassembly and assembly, use care to prevent damage to machined surfaces and splines. Cleanliness is extremely important when servicing a CV joint.
- Always use the specified lubricant.
- An assembled CV joint may be damaged if it is "over-plunged" outward from the joint housing.

**Wheel and Tire Balancing**

**WARNING: ON-VEHICLE FRONT WHEEL AND TIRE BALANCING WITH FRONT SUSPENSION IN THE FULLY EXTENDED (REBOUND) POSITION MAY OVERHEAT AND DAMAGE THE CV JOINTS. PROPER BALANCING REQUIRES THAT THE FRONT WHEEL(S) AND TIRE(S) BE LIFTED OFF THE GROUND BY PLACING A JACK UNDER THE FRONT SUSPENSION LOWER ARM.**

**ANOTHER METHOD IS TO REMOVE THE FRONT WHEEL(S) AND TIRE(S) FROM THE VEHICLE FOR BALANCING.**

**Hoisting**

Never raise the vehicle using the halfshafts as lift points. Refer to Section 00-02.

**Towing**

Never tow the vehicle using the halfshafts as anchor points for the safety chains.

**Undercoating and Rustproofing**

Extreme care must be taken during undercoating and rustproofing procedures to protect the CV joint boots. Compounds that stick to the boot convolutions will cause rapid deterioration of the CV joint boots.

**DIAGNOSIS**

Front-wheel drive CV joints and halfshaft assemblies rarely need service. Halfshaft assemblies and CV joints rotate at one-third the speed of rear wheel drive driveshafts and do not contribute to rotational vibrational disturbance.

1. Check the boots on the halfshaft for cracks, damage, leaking grease, or loose boot bands. If any damage is found, replace the boot.
  - Out of balance front tires.
  - Out of round (radial runout) in front tires.
  - Lateral runout in front tires.
  - Improperly seated front CV joint in the front wheel hub.
  - Worn bearings in front hub.
2. If there is vibration at highway speeds, check for the following:
  - Out of balance front tires.
  - Out of round (radial runout) in front tires.
  - Lateral runout in front tires.
  - Improperly seated front CV joint in the front wheel hub.
  - Worn bearings in front hub.
3. If there is a noticeable metallic click when going over bumps, put the vehicle on a drive-on type rack and jounce the vehicle. Try to locate where the sound is coming from and then do further diagnosis.

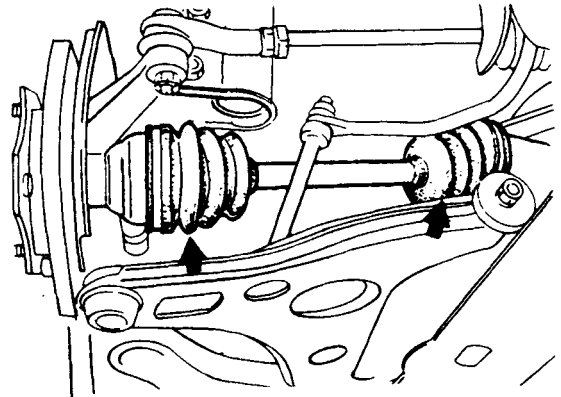

E7178-A

4. If there is shudder or vibration on acceleration, put the vehicle on a suitable hoist and check for spline and CV joint looseness. Turn the halfshaft by hand and make sure the splines and joints are not excessively loose.

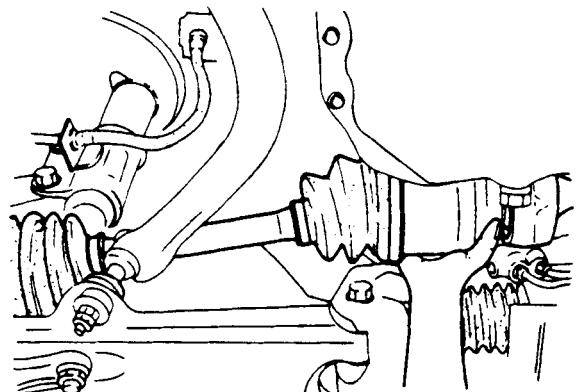

E7179-A

## DIAGNOSIS (Continued)

5. Make sure the halfshaft is not twisted or cracked. If the halfshaft is equipped with a vibration damper, make sure it is not damaged or loose on the shaft.

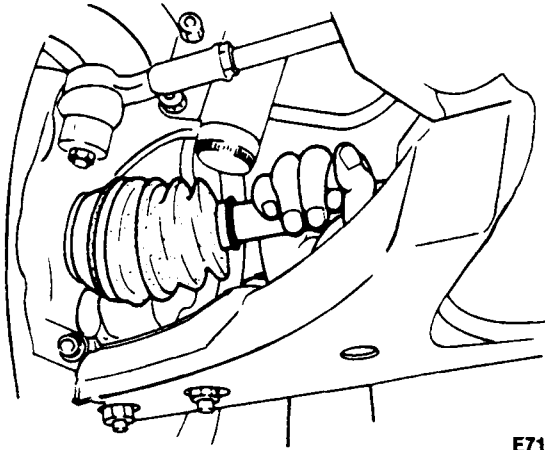

E7180-A

6. If necessary, disassemble and repack the CV joints. Check for worn bearings, cages, scratches and scoring, worn trunions, heat damage, and worn or scored runways in the CV joint housings.
7. If the halfshaft length is incorrect or is pulling out of the transaxle case, check for the following:
- Engine or transaxle misalignment. Check engine mounts for damage.
  - Check for signs of an accident as indicated by a repainted fender or slightly wrinkled sheet metal on the fender wells or strut towers. If necessary, check underbody dimensions.
  - Check for worn or damaged front suspension parts. Check for worn ball joints and tie rod ends, worn control arm bushings, worn upper strut bushing and bearing, bent control arms or stabilizer bars.

CONDITION	POSSIBLE SOURCE	ACTION
<ul style="list-style-type: none"> <li>Damaged Operation of Halfshaft</li> </ul>	<ul style="list-style-type: none"> <li>Broken ball joint.</li> <li>Broken tripod joint.</li> <li>Worn or seized joint.</li> </ul>	<ul style="list-style-type: none"> <li>Replace.</li> <li>Replace.</li> <li>Replace.</li> </ul>
<ul style="list-style-type: none"> <li>Abnormal Noise from Halfshaft</li> </ul>	<ul style="list-style-type: none"> <li>Insufficient grease in joint or spline.</li> <li>Excessive backlash on spline.</li> <li>Worn joint.</li> </ul>	<ul style="list-style-type: none"> <li>Replenish or replace.</li> <li>Replace.</li> <li>Replace.</li> </ul>
<ul style="list-style-type: none"> <li>Steering Wheel Pulls: While driving on a straight and level road, the steering wheel pulls toward either right of left side.</li> </ul>	<ul style="list-style-type: none"> <li>Incorrect front wheel bearing preload adjustment.</li> <li>Bent steering linkage.</li> <li>Fatigued coil spring.</li> <li>Lower arm bushing worn or damaged.</li> <li>Bent knuckle arm.</li> <li>Bent lower arm or loose mounting.</li> <li>Incorrect toe-in adjustment.</li> <li>Improper tire air pressure.</li> <li>Unevenly worn tires (difference in wear between left and right tires).</li> <li>Brake dragging.</li> </ul>	<ul style="list-style-type: none"> <li>Adjust or replace. Refer to Section 04-01.</li> <li>Refer to Section 11-00.</li> <li>Refer to Section 04-01.</li> <li>Refer to Section 04-01.</li> <li>Replace.</li> <li>Refer to Section 04-01.</li> <li>Refer to Section 04-00.</li> <li>Refer to Section 04-04.</li> <li>Refer to Section 04-04.</li> <li>Refer to Section 06-00.</li> </ul>
<ul style="list-style-type: none"> <li>Unstable Handling</li> </ul>	<ul style="list-style-type: none"> <li>Incorrect wheel bearing preload adjustment.</li> <li>Bent steering linkage.</li> <li>Joint in steering system worn or damaged.</li> <li>Incorrect steering pinion preload adjustment.</li> <li>Fatigued coil spring.</li> <li>Damaged shock absorbers.</li> <li>Lower arm bushing worn or damaged.</li> <li>Incorrect toe-in adjustment (front or rear).</li> <li>Improper tire air pressure.</li> <li>Wheels bent or unbalanced.</li> </ul>	<ul style="list-style-type: none"> <li>Adjust or replace. Refer to Section 04-01.</li> <li>Refer to Section 11-00.</li> <li>Refer to Section 11-04.</li> <li>Refer to Section 11-00.</li> <li>Refer to Section 04-01.</li> <li>Refer to Section 04-01.</li> <li>Refer to Section 04-01.</li> <li>Refer to Section 04-00.</li> <li>Refer to Section 04-04.</li> <li>Refer to Section 04-04.</li> </ul>

## DIAGNOSIS (Continued)

CONDITION	POSSIBLE SOURCE	ACTION
<ul style="list-style-type: none"> <li>Excessive Steering Wheel Play</li> </ul>	<ul style="list-style-type: none"> <li>Damaged front wheel bearing.</li> <li>Incorrect steering pinion preload adjustment.</li> <li>Rack and pinion worn.</li> <li>Joint in steering system worn or damaged.</li> <li>Lower arm bushing worn or damaged.</li> </ul>	<ul style="list-style-type: none"> <li>Adjust.</li> <li>Refer to Section 11-00.</li> <li>Refer to Section 11-00.</li> <li>Refer to Section 11-04.</li> <li>Refer to Section 04-01.</li> </ul>
<ul style="list-style-type: none"> <li>Tires are Excessively Worn or Worn Unevenly</li> </ul>	<ul style="list-style-type: none"> <li>Incorrect wheel bearing preload adjustment (excessively loose).</li> <li>Incorrect toe-in adjustment.</li> <li>Improper tire air pressure.</li> <li>Unbalanced wheel(s).</li> </ul>	<ul style="list-style-type: none"> <li>Adjust.</li> <li>Refer to Section 04-00.</li> <li>Refer to Section 04-04.</li> <li>Refer to Section 04-04.</li> </ul>
<ul style="list-style-type: none"> <li>Abnormal Noise from Halfshaft</li> </ul>	<ul style="list-style-type: none"> <li>Damaged wheel bearing.</li> </ul>	<ul style="list-style-type: none"> <li>Replace.</li> </ul>

## REMOVAL AND INSTALLATION

## Halfshaft

## Removal

NOTE: When removing both halfshafts, Differential Plugs T87C-7025-C or equivalent must be installed to prevent oil leakage.

1. Raise the vehicle. Refer to Section 00-02. Remove the necessary engine compartment underbody covers.
2. Remove the stabilizer bar to control arm retaining nuts, bolt, washers and bushings.

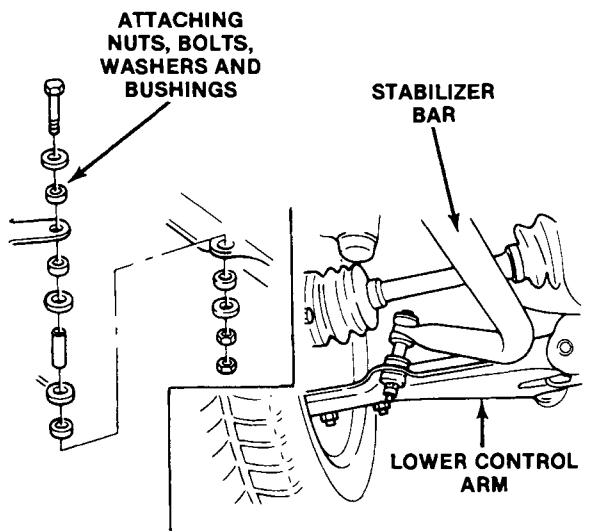

E6810-A

3. Remove the wheel and tire assembly.
4. Carefully raise the staked portion of the halfshaft attaching nut using a small cape chisel.

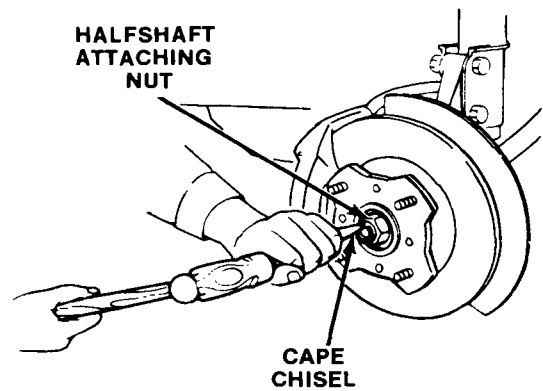

E6804-A

5. Loosen, but do not remove, the halfshaft attaching nut.  
NOTE: When loosening the nut, lock the hub by applying the brakes.
6. Remove the lower control arm ball joint clamp bolt.

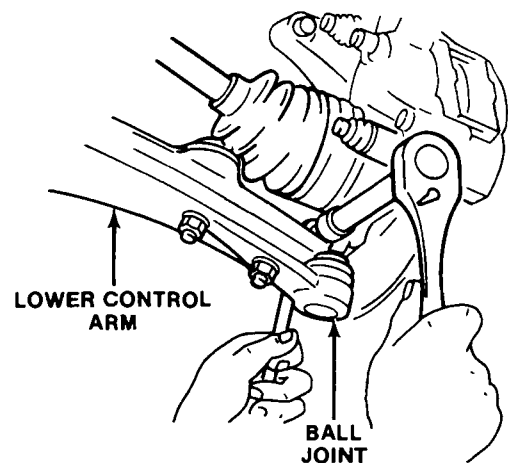

E6811-A

7. Pry downward on the lower control arm to separate the ball joint from the steering knuckle.

## REMOVAL AND INSTALLATION (Continued)

8. Separate the halfshaft from the transaxle on MTX vehicles as follows.

- a. Pull outward on the steering knuckle / brake assembly to separate the halfshaft from the transaxle.

**CAUTION:** To prevent damage to the transaxle oil seal, do not pull the halfshaft all the way out of the transaxle. Apply only enough force to loosen the shaft from the differential side gear.

MTX

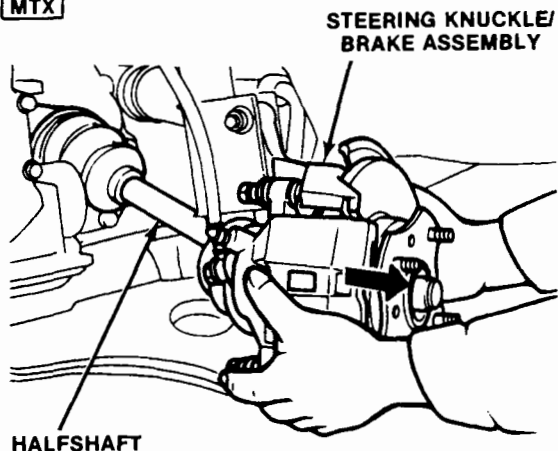

E6812-A

- b. If the halfshaft is difficult to remove, a pry bar can be used to loosen it from the differential side gear. Insert the bar between the halfshaft and the transaxle case. Lightly tap on the end of the bar until the halfshaft loosens from the differential side gear.

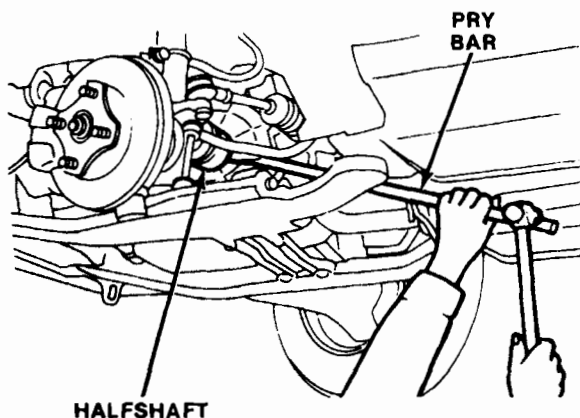

E6813-A

**CAUTION:** Extreme care must be taken to ensure the pry bar does not damage the transaxle case, transaxle oil seal, CV joint or CV joint boot.

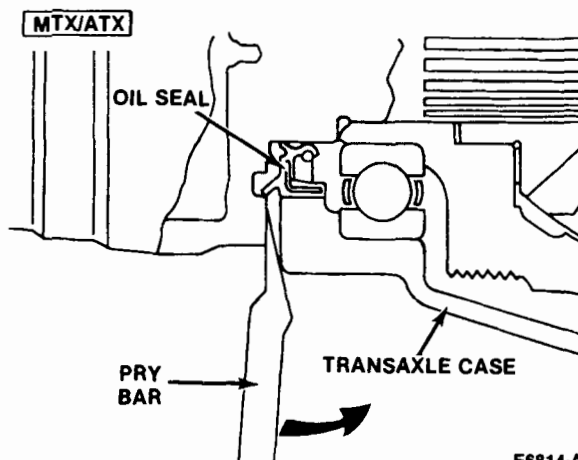

E6814-A

9. To separate the halfshaft from the transaxle on ATX vehicles, insert a pry bar between the transaxle case and the halfshaft. Lightly tap on the end of the bar until the halfshaft loosens from the differential side gear.

ATX

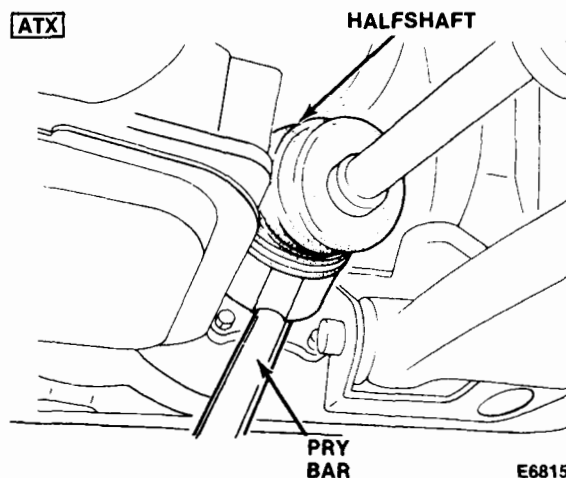

E6815-A

**CAUTION:** Extreme care must be taken to ensure the pry bar does not damage the transaxle case, transaxle oil seal, CV joint or CV joint boot.

10. Remove the halfshaft retaining nut and washer. Discard the nut. It must not be reused.



## REMOVAL AND INSTALLATION (Continued)

11. Pull the halfshaft out of the wheel hub.

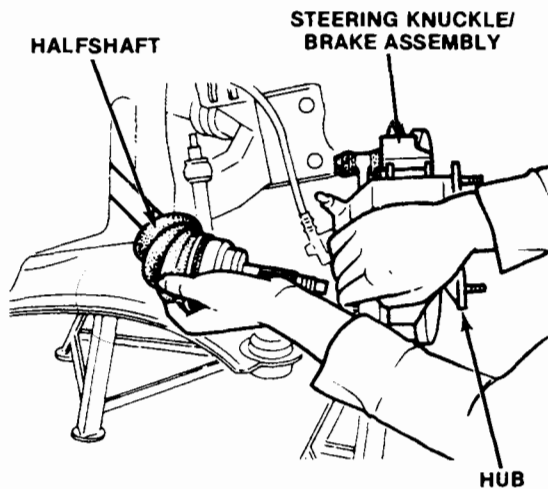

E6819-A

**NOTE:** If the wheel hub binds on the halfshaft splines, it can be loosened using 2 Jaw Puller D80L-1002-L or equivalent.

**CAUTION:** Never use a hammer to separate the halfshaft from the wheel hub. Damage to the CV joint internal components will result.

12. Support the halfshaft and slide it out of the transaxle.

Use care to prevent damage to the transaxle oil seal.

13. Install Differential Plugs T87C-7025-C or equivalent to prevent oil leakage.

**Installation**

1. Install a new circlip on the inboard CV joint stub shaft.

**CAUTION:** The original circlip must not be reused.

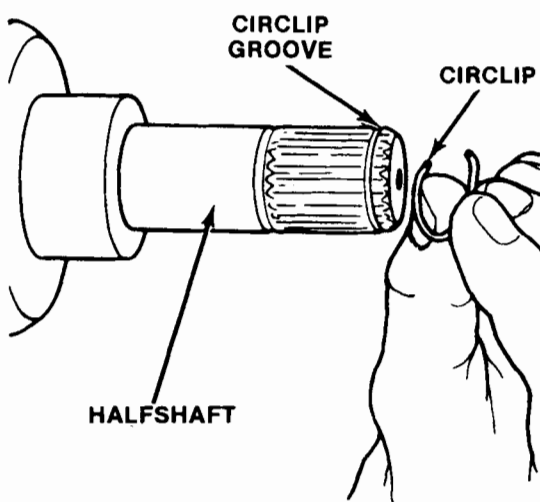

E6820-A

**NOTE:** To install the circlip properly, start one end in the groove and work the circlip over the stub shaft end and into the groove. This will avoid over-expanding of the circlip.

2. Make sure the dynamic damper, if equipped, is positioned properly.
3. Inspect the transaxle oil seal. If it shows any signs of wear or damage that may cause a leak, replace the seal. Refer to Section 07-03A or 07-03B.
4. Remove the Differential Plugs T87C-7025-C or equivalent.
5. Make sure the circlip gap is positioned at the top of the halfshaft splines and lightly lubricate the splines with Premium Long-Life Grease C1AZ-19590-E (ESA-M1C75-B) or equivalent.

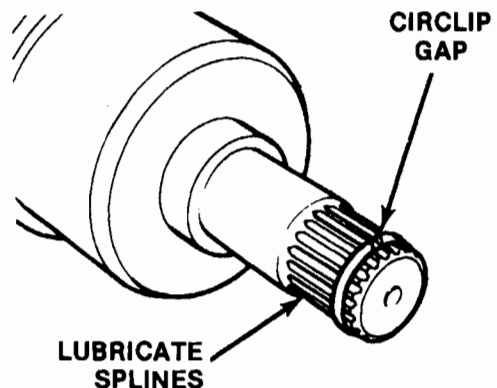

E6821-A

6. Carefully align the CV joint splines with the differential side gear splines and push the halfshaft into the differential.

**NOTE:** When it seats properly, the circlip can be felt as it snaps into the differential side gear groove.

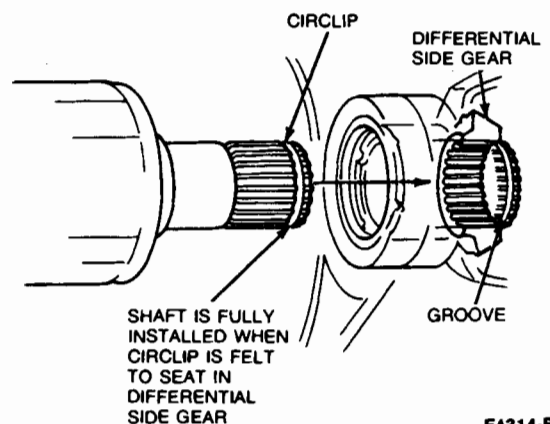

E4314-B

## REMOVAL AND INSTALLATION (Continued)

7. Position the halfshaft through the wheel hub and install a new attaching nut. Do not tighten the nut at this time.

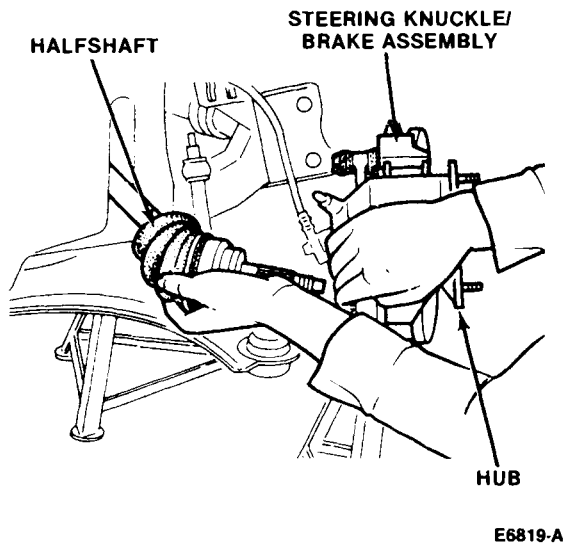

8. Position the lower control ball joint through the steering knuckle.

9. Install the pinch bolt and retaining nut. Tighten the attaching nut to 43-54 N·m (32-40 lb-ft).
10. Position the stabilizer bar and install the retaining bolt, nuts, washers and bushings. Tighten the nut until 10.8mm (7/16 inch) of the bolt threads extend beyond the nut.
11. Install the removed underbody covers.
12. Install new halfshaft retaining nut and tighten to 157-235 N·m (116-174 lb-ft).

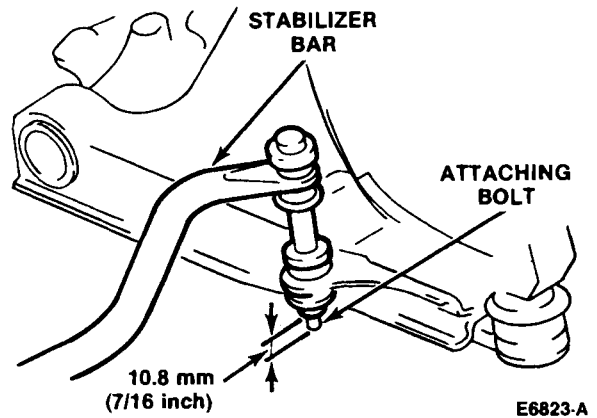

13. Stake the halfshaft retaining nut using a cold chisel with the cutting edge rounded as shown.

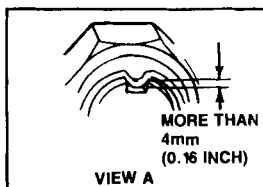
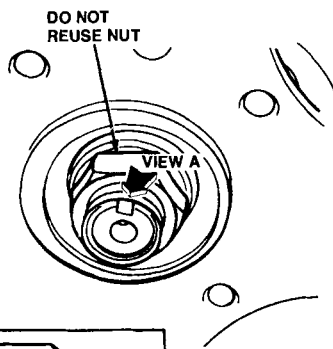

RADIUS  
1.5mm ± .25  
(0.06 ± .01)

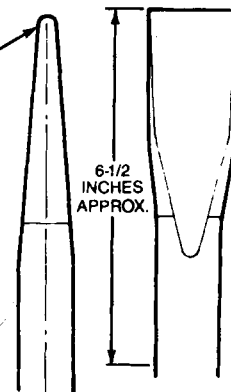

THE STAKING TOOL CAN BE FABRICATED FROM AN EXISTING HARDENED CHISEL. THE CORRECT RADIUS ON THE CHISEL TIP WILL PREVENT IMPROPER STAKING. DO NOT ATTEMPT TO STAKE WITH A SHARP EDGED TOOL.

E7563-A

**CAUTION:** If the nut splits or cracks after staking, it must be replaced with a new nut.

14. Install the wheel and tire. Tighten retaining nuts to 90-120 N·m (65-88 lb-ft).
15. Install underbody covers.
16. Lower vehicle.

## DISASSEMBLY AND ASSEMBLY

## Jointshaft

## Turbocharged Vehicles

## Disassembly

1. Separate intermediate shaft from halfshaft.

**DISASSEMBLY AND ASSEMBLY (Continued)**

- Remove circlip from intermediate shaft and press off bearing assembly.

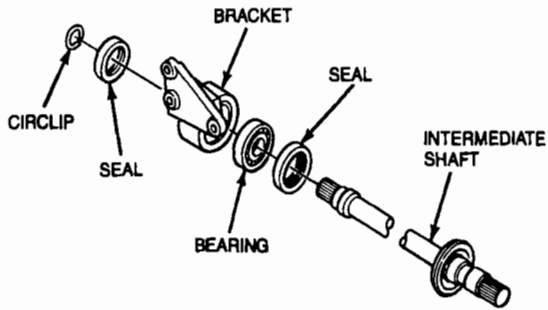

E7541-A

- Press bearing out of the bracket.
- Inspect bracket for damage or wear, replace if necessary.

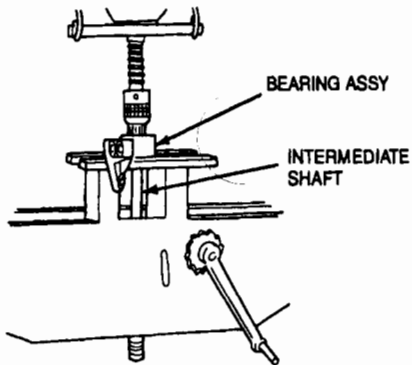

E7542-A

**Assembly**

- Press new bearing into bracket.
- Install new seals.
- Install bearing assembly on intermediate shaft.

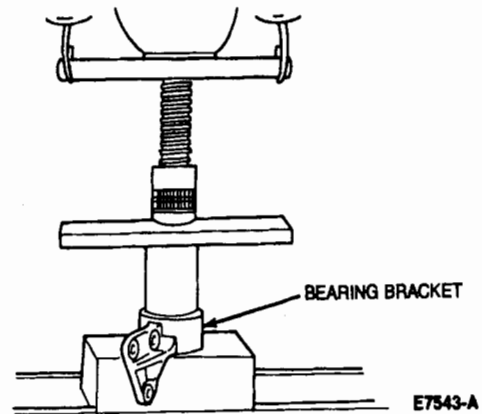

- Install new circlip.
- Assemble intermediate shaft to halfshaft.

## DISASSEMBLY AND ASSEMBLY (Continued)

## Rzeppa CV Joint

## Disassembled View

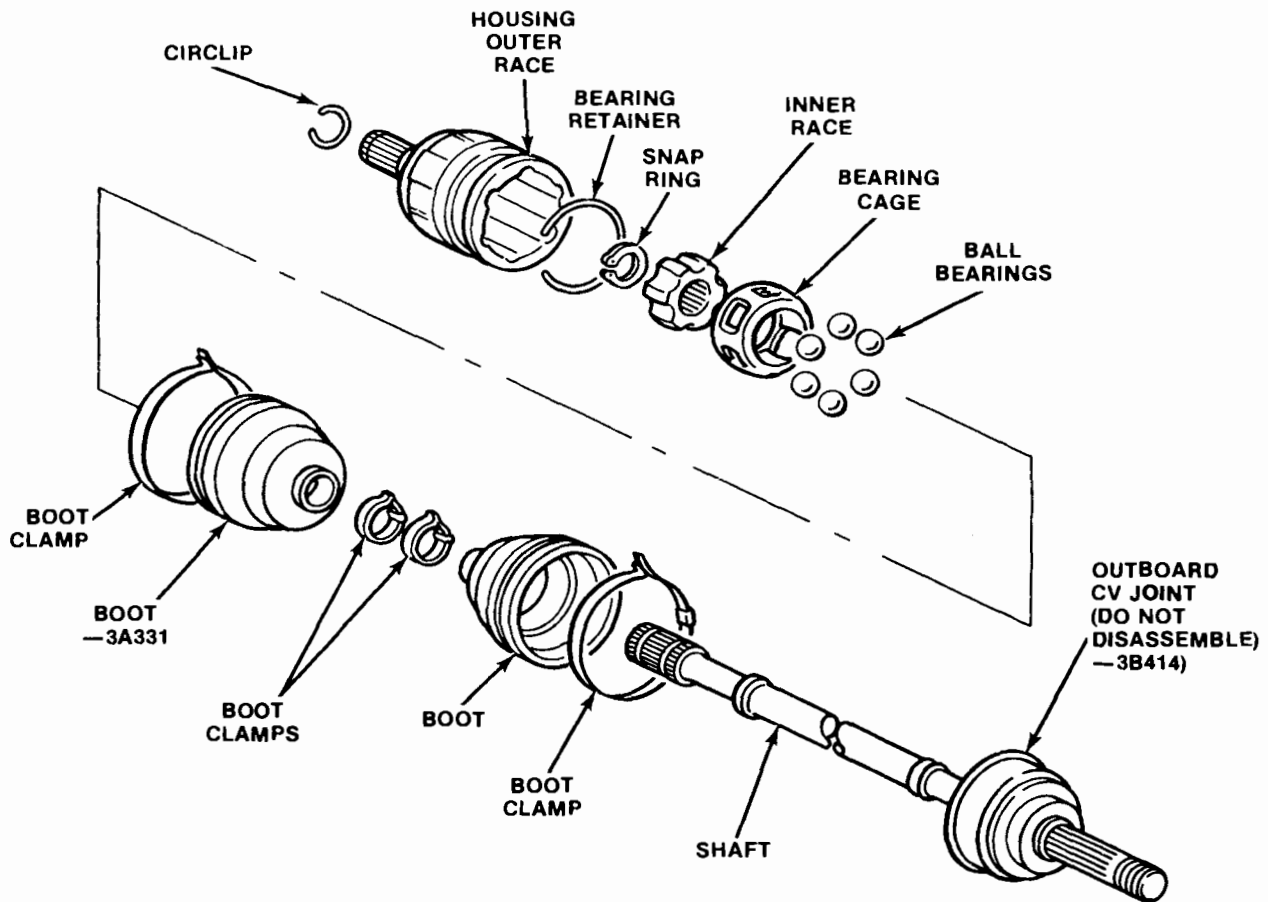

E6818-A

## Disassembly

NOTE: The CV joint components are matched during manufacture and therefore cannot be interchanged with components from another CV joint. Extreme care should be taken not to mix or substitute like components between CV joints.

1. Clamp the halfshaft in a vise. Do not allow the vise to contact the boot or its clamps.

**CAUTION: The vise should be equipped with jaw caps to prevent damage to any machined surfaces.**

2. Remove the large boot clamp using side cutters. After removing the clamp, roll the boot back over the shaft.

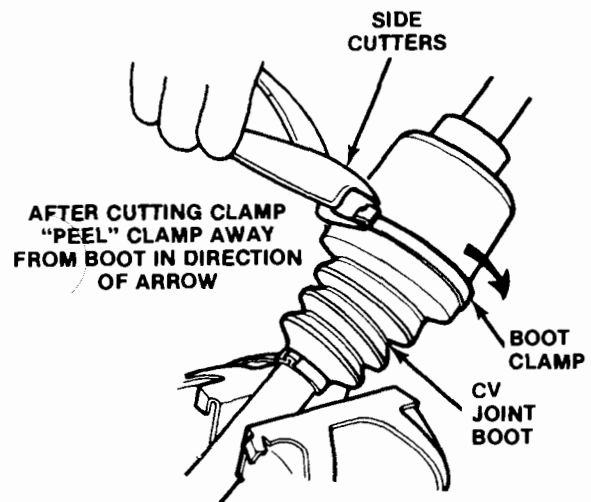

E6851-A

**DISASSEMBLY AND ASSEMBLY (Continued)**

NOTE: If this procedure is being done to replace only a damaged boot, the grease should be checked for contamination. The grease can be checked by rubbing it between two fingers. Any gritty feeling indicates a contaminated CV joint.

NOTE: A contaminated CV joint must be completely disassembled, cleaned and inspected. If the grease is not contaminated and the CV joint has been operating satisfactorily replace only the boot and add the required lubricant.

**CHECK LUBRICANT FOR CONTAMINATION BY RUBBING BETWEEN TWO FINGERS. ANY GRITTY FEELING INDICATES A CONTAMINATED CV JOINT.**

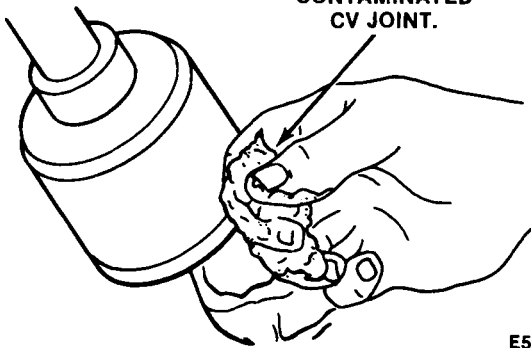

E5492-A

NOTE: Before removing the bearing retainer, paint alignment marks on the outer race and shaft for assembly reference.

- 3. Remove the wire ring bearing retainer.

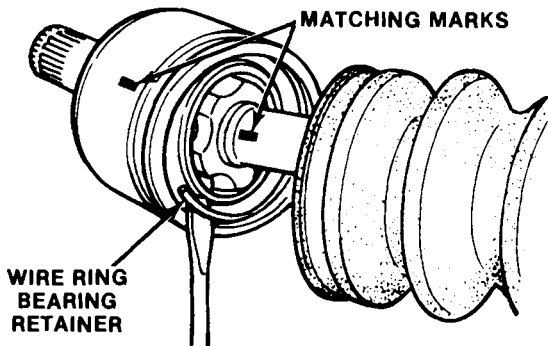

E6852-A

- 4. Remove the outer race.

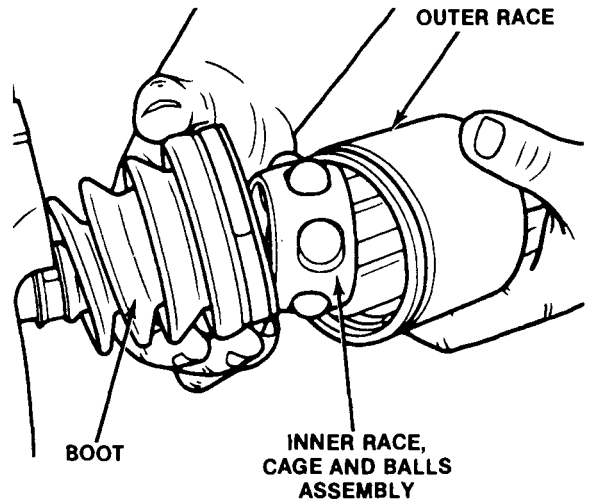

E6853-A

NOTE: Before removing the snap ring, paint alignment marks on the inner race and shaft.

- 5. Remove the inner race snap ring from the end of the halfshaft.

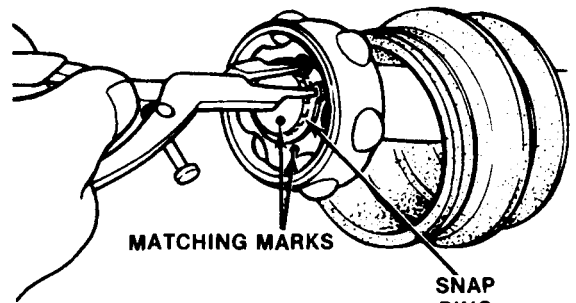

E6854-A

- 6. Remove the inner race, cage and ball bearings from the shaft as an assembly.

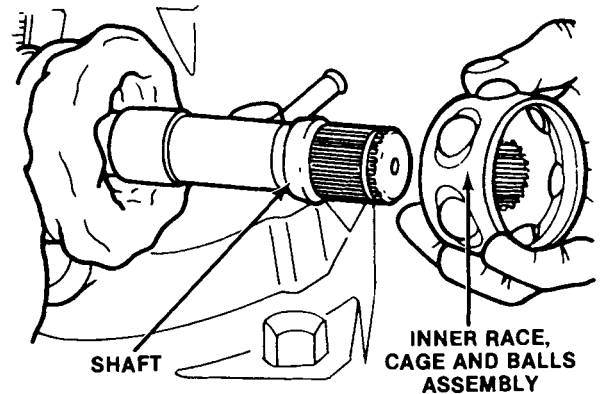

E6855-A

## DISASSEMBLY AND ASSEMBLY (Continued)

**CAUTION:** Use care to prevent damage to the bearing surfaces and cage. An old screwdriver with the blade blunted on a grinder or with a file can be used.

7. Pry the ball bearing out of the bearing cage using a screwdriver.

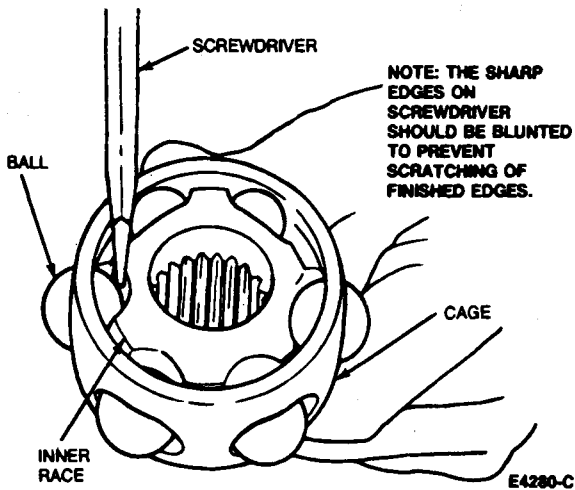

**NOTE:** Mark the inner race and the bearing cage for proper assembly.

8. Rotate the inner race to align the bearing lands with windows in the bearing cage. Remove the inner race through the larger end of the cage.

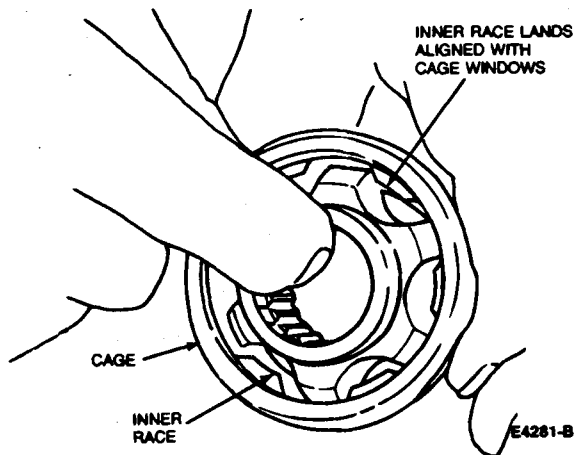

9. If necessary, remove the small clamp and remove the boot from the halfshaft.

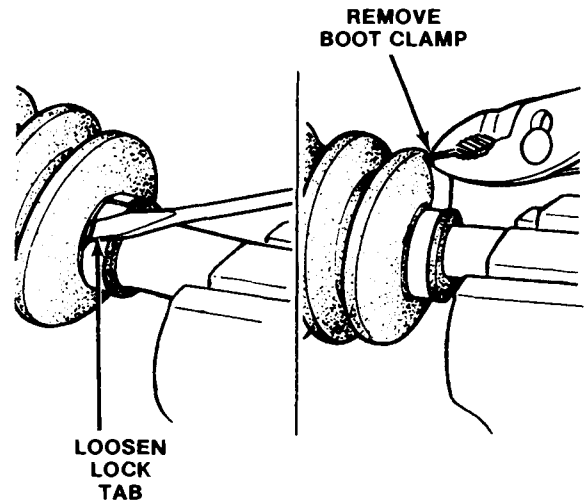

E6857-A

10. If the boot is to be reused, wrap the halfshaft splines with tape before removing.

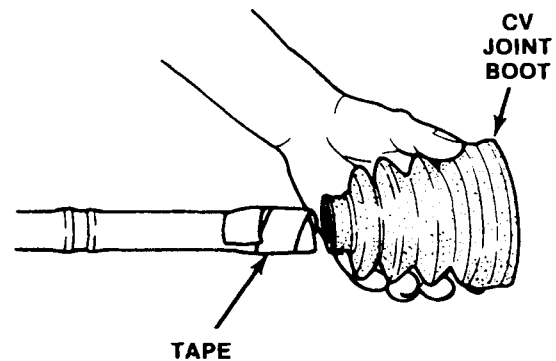

E6870-A

**Assembly**

**NOTE:** The CV joint must be lubricated with High-Temp Constant Velocity Joint Grease E43Z-19590-A (ESP-M1C207-A) or equivalent.

1. If boot is being reused, cover the halfshaft splines with tape and install the CV joint boot.
2. Lubricate the inner race, bearing cage and ball bearings with the specified grease.

**DISASSEMBLY AND ASSEMBLY (Continued)**

3. Position the inner race in the bearing cage and align match marks.

NOTE: Install the race with the chamfered splines facing the large end of the cage.

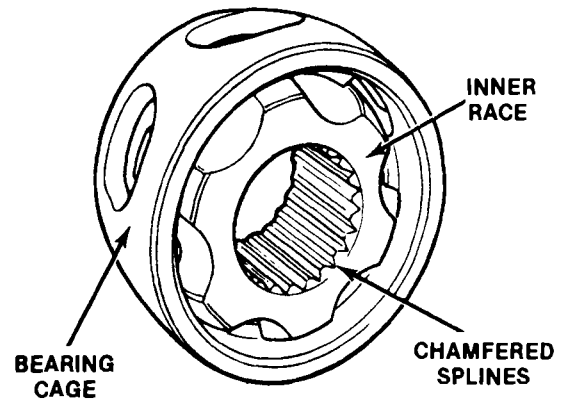

E6858-A

4. Install the ball bearings in the bearing cage. The balls can be pressed into the cage windows with heel of the hand.

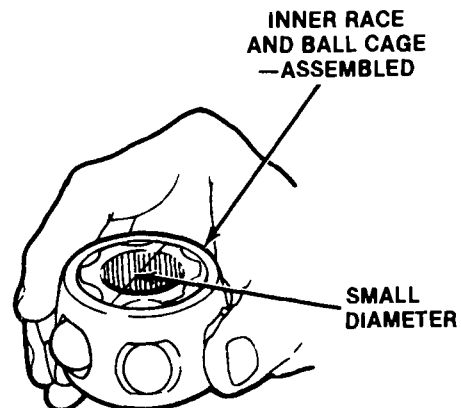
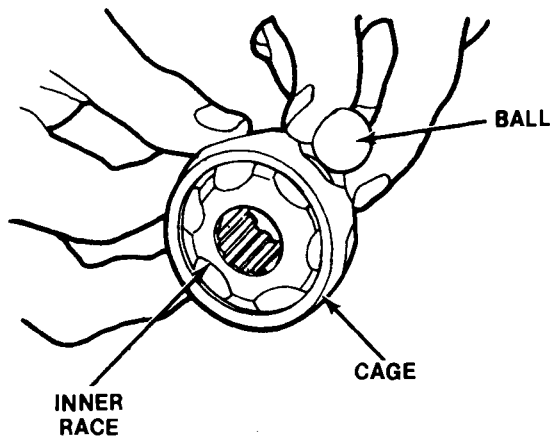

E6859-A

5. Install the inner race, cage and balls on the halfshaft as an assembly.

NOTE: Make sure the chamfer on the bearing cage faces the snap ring and that paint marks made during removal line up.

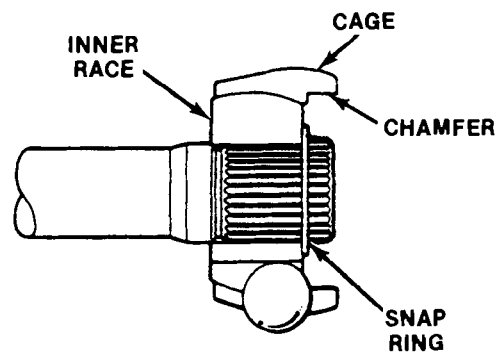

E6860-A

## DISASSEMBLY AND ASSEMBLY (Continued)

6. Install the inner race snap ring.
7. Lubricate the outer race with 40-60 grams (1.4-2.1 oz) of the specified grease.
8. Install the outer race.

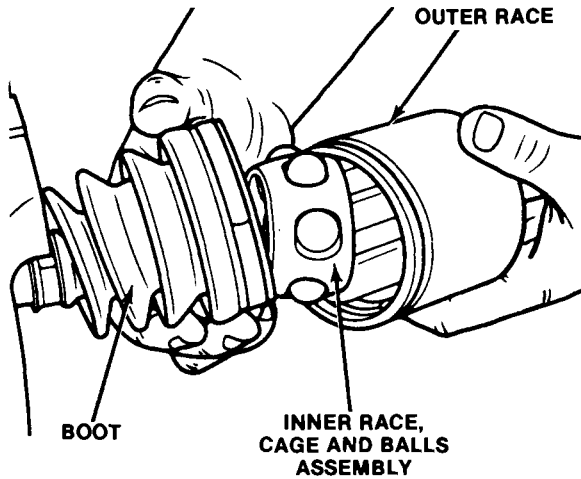

E8853-A

9. Add another 20-30 grams (0.7-1.0 oz) of the specified lubricant to the outer race.
10. Install the wire ring bearing retainer.

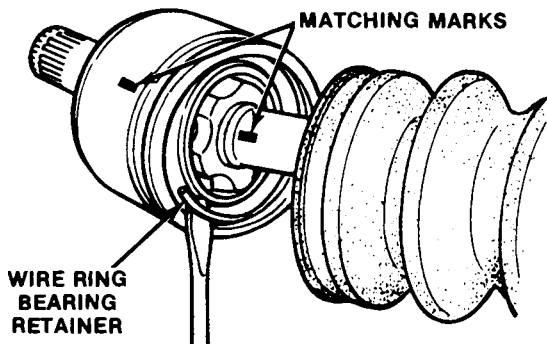

E8852-A

11. Position the boot. Make sure the boot is fully seated in the grooves in the shaft and outer race.

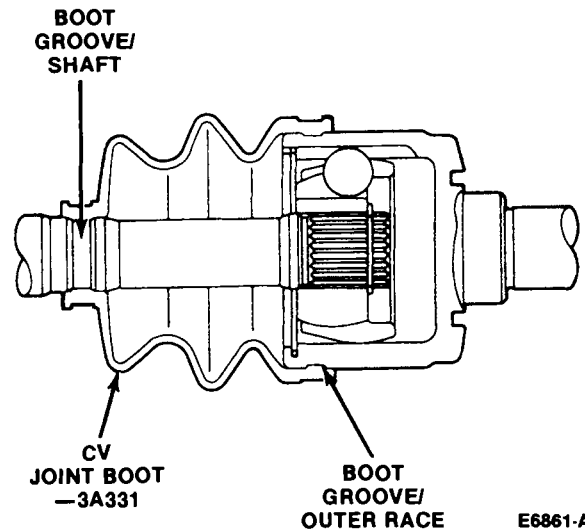

E8861-A

12. Extend or compress the CV joint as necessary until the distance between the boot clamp grooves measures 90mm (3.5 inch). Do not allow this dimension to change until the boot clamps are installed.

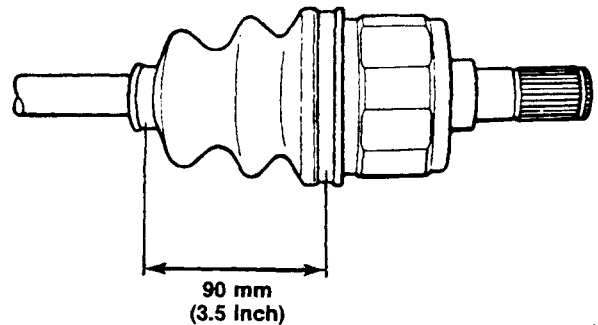

E8865-A

13. Insert a dulled screwdriver blade between the boot and the outer bearing race to allow trapped air to escape from the boot.

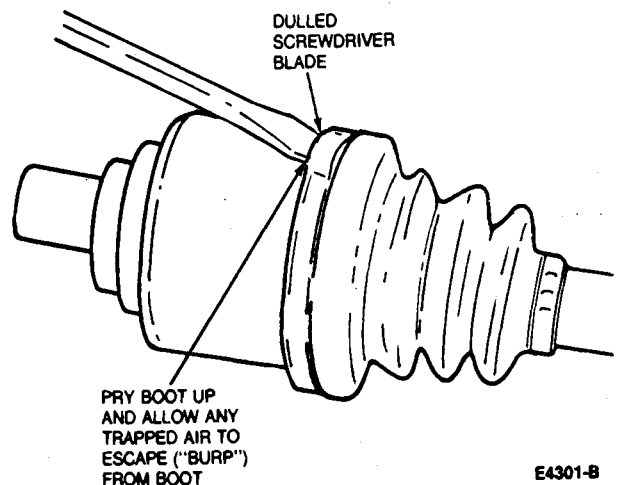

E4301-B

14. Install new boot clamp(s).



**DISASSEMBLY AND ASSEMBLY (Continued)**

15. Wrap the clamps around the boots in a clockwise direction, pull tight with pliers and bend the locking tabs to secure in position.

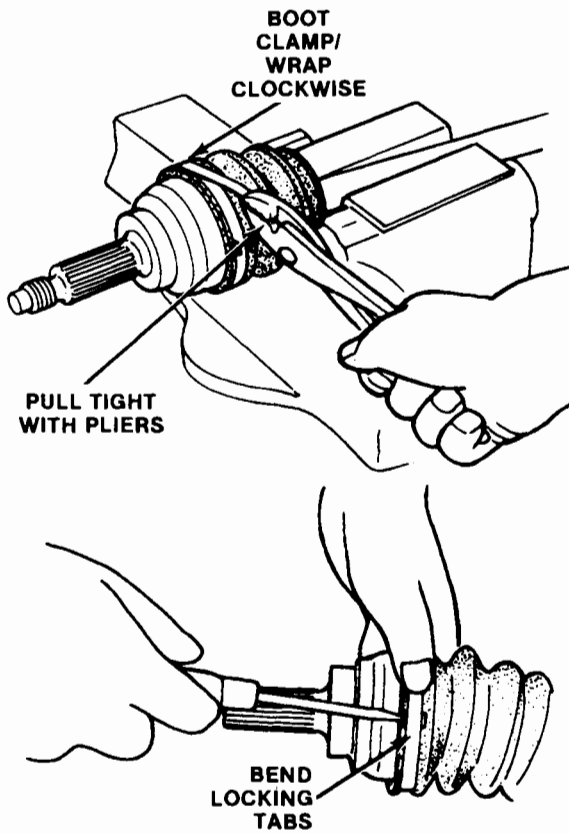

E6862-A

16. Work the CV joint through its full range of travel at various angles. The joint should flex, extend and compress smoothly.

17. If boot was reused, remove tape.

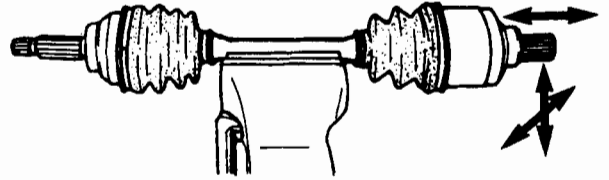

E6864-A

## DISASSEMBLY AND ASSEMBLY (Continued)

## Tripot Joint

## Disassembly

## Tripot Joint — Disassembled View

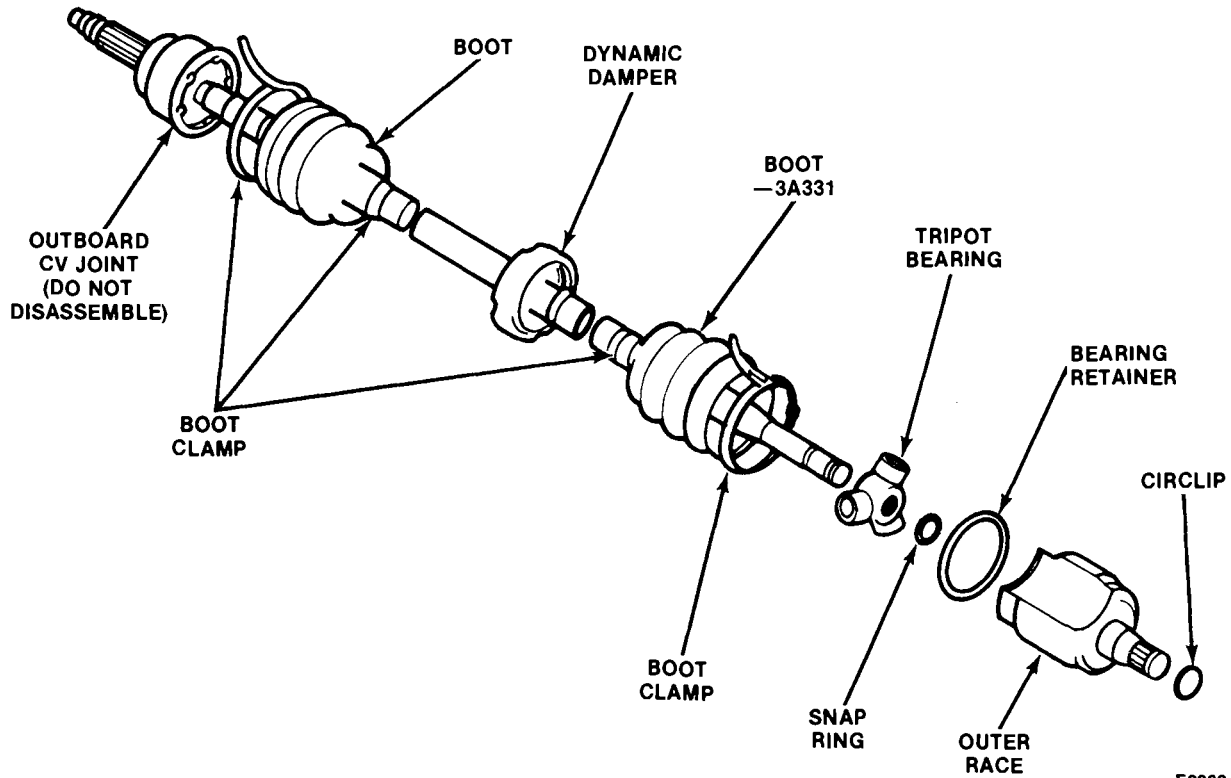

E6863-A

1. Clamp the halfshaft in a vise. Do not allow the vise to contact the boot or its clamps.  
**CAUTION: The vise should be equipped with jaw caps to prevent damage to any machined surfaces.**
2. Remove the large boot clamp using side cutters. Then, roll the boot back over the shaft.

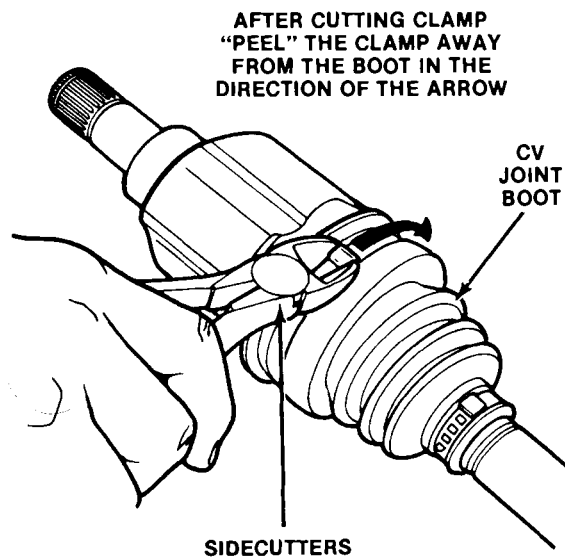

E6873-A

**DISASSEMBLY AND ASSEMBLY (Continued)**

NOTE: If this procedure is being done to replace only a damaged boot, the grease should be checked for contamination by rubbing it between two fingers. Any gritty feeling indicates a contaminated CV joint.

NOTE: A contaminated CV joint must be completely disassembled, cleaned and inspected. If the grease is not contaminated and the CV joint has been operating satisfactorily replace only the boot and add the required lubricant.

**CHECK LUBRICANT FOR CONTAMINATION BY RUBBING BETWEEN TWO FINGERS. ANY GRITTY FEELING INDICATES A CONTAMINATED CV JOINT.**

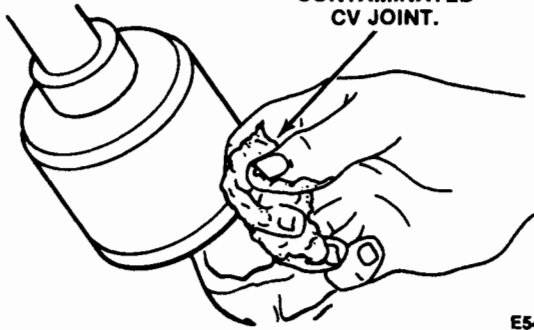

E5492-A

- 3. Remove the wire ring bearing retainer.

**WIRE RING BEARING RETAINER/REMOVAL**

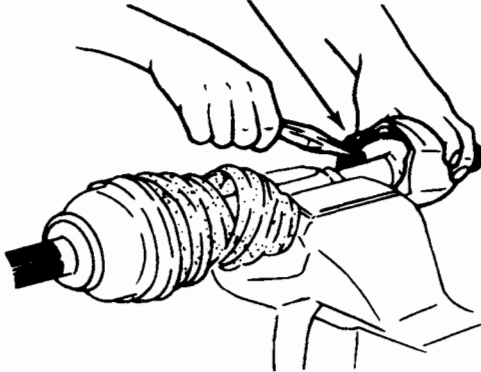

E6866-A

NOTE: Before removing the outer race, paint alignment marks on the outer race and tripot bearing for assembly reference.

- 4. Remove the outer race.

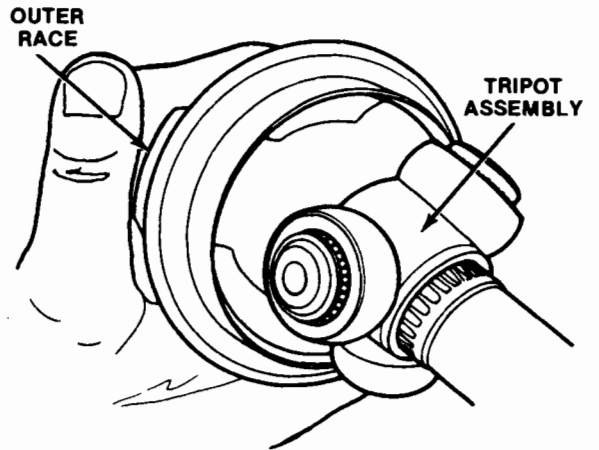

E6867-A

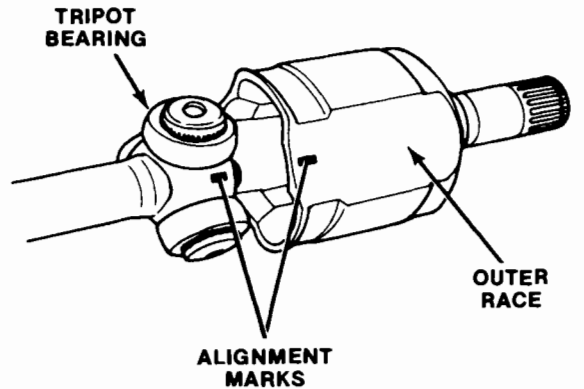

E6874-A

NOTE: Before removing the snap ring, paint alignment marks on the tripot bearing and shaft for assembly reference.

- 5. Remove the tripot bearing snap ring.

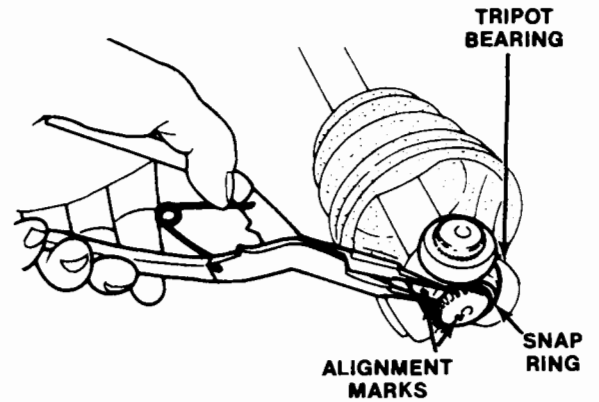

E6868-A

## DISASSEMBLY AND ASSEMBLY (Continued)

6. Using a brass drift and hammer, remove the tripod bearing from the shaft.

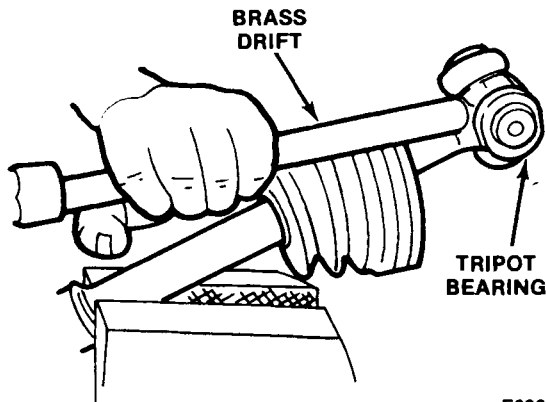

E6869-A

7. If necessary, remove the small clamp and the CV joint boot from the halfshaft.

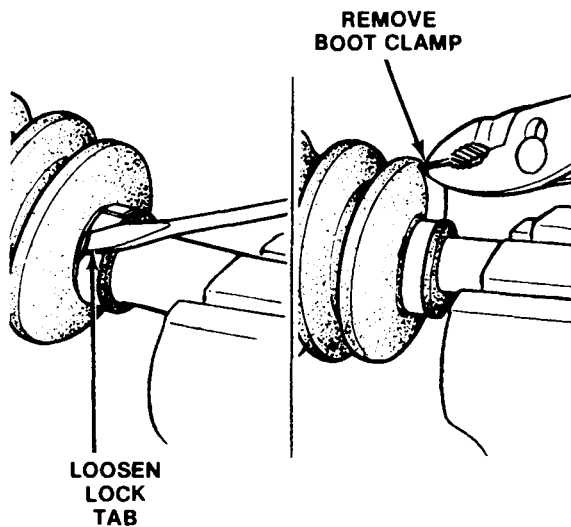

E6857-A

8. If the boot is to be reused, wrap the halfshaft splines with tape before removing it from the shaft.

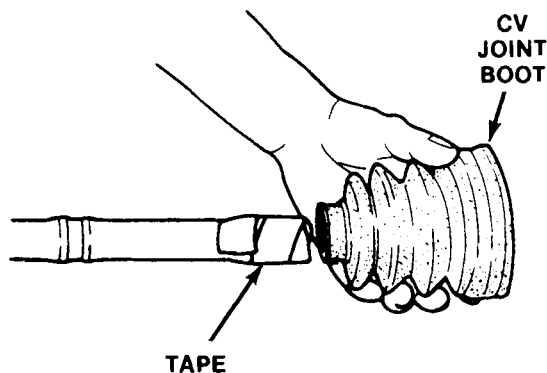

E6870-A

## Assembly

NOTE: The CV joint must be lubricated with High-Temp Constant Velocity Joint Grease E43Z-19590-A (ESP-M1C207-A) or equivalent.

1. If boot is reused, cover the halfshaft splines with tape and install the CV joint boot.
2. Install the tripod assembly on the halfshaft.

NOTE: Tap the assembly onto the shaft using a hammer and brass drift.

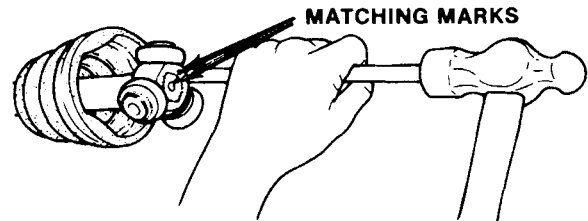

E6871-A

3. Install the tripod assembly retaining ring.
4. Fill the CV joint outer race with 100 grams (3.5 oz) of the specified grease.
5. Install the outer race over the tripod joint and install the wire ring bearing retainer.
6. Position the CV joint boot. Make sure the boot is fully seated in the grooves in the shaft and outer race.
7. Extend or compress the joint as necessary until the distance between the CV joint boot clamp grooves measures 90mm (3.5 inch).

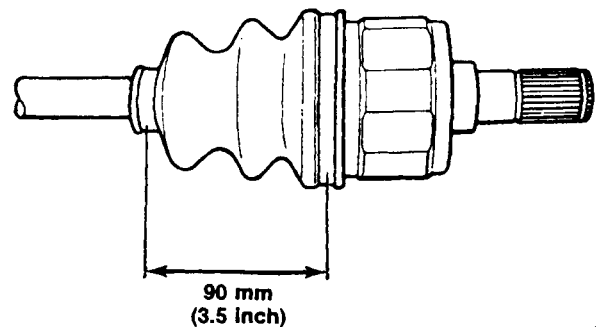

E6865-A

**DISASSEMBLY AND ASSEMBLY (Continued)**

8. Insert a dulled screwdriver blade between the boot and the outer bearing race to allow trapped air to escape from the boot.

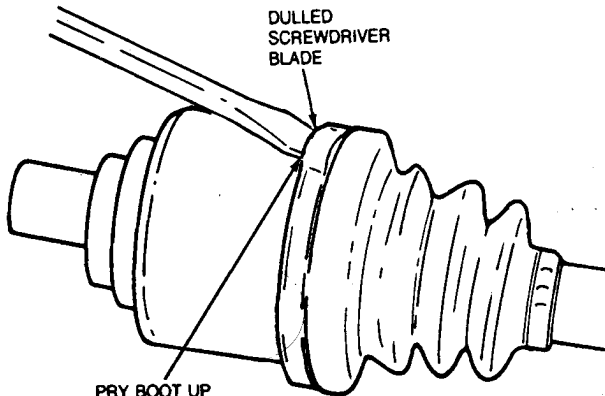

PRY BOOT UP AND ALLOW ANY TRAPPED AIR TO ESCAPE ("BURP") FROM BOOT

E4301-B

9. Install new boot clamp(s). Wrap the clamps around the boots in a clockwise direction, pull tight with pliers and bend the locking tabs to secure in position.

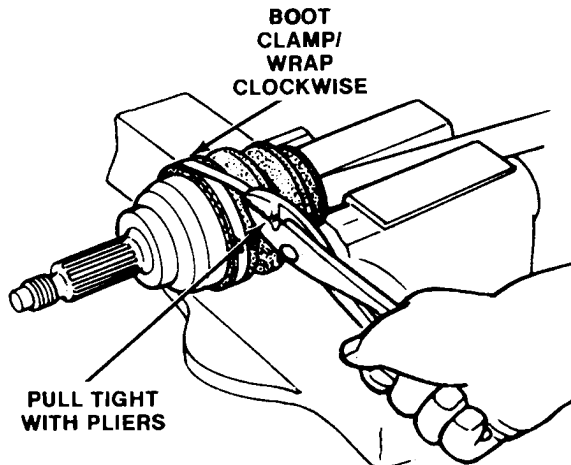

PULL TIGHT WITH PLIERS

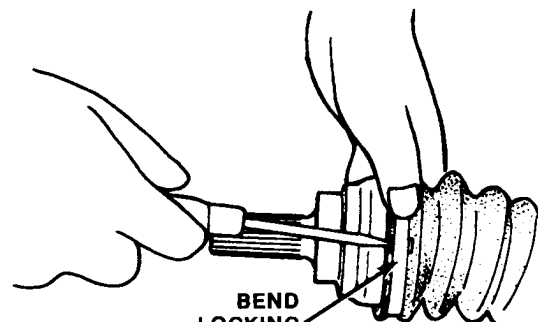

BEND LOCKING TABS

E6862-A

10. Work the CV joint through its full range of travel at various angles. The joint should flex, extend and compress smoothly.

11. If boot was reused, remove tape.

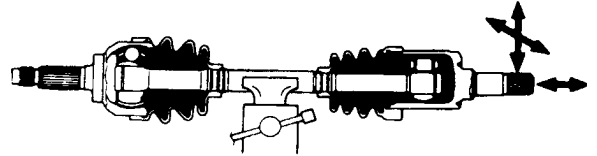

E6872-A

**SPECIFICATIONS**

**TORQUE SPECIFICATIONS**

Description	N·m	Lb·Ft
Ball Joint Pinch Bolt	43-54	32-40
Halfshaft Retaining Nut	157-235	116-174
Wheel Retaining Nuts	90-120	65-88

**SPECIAL SERVICE TOOLS**

Tool Number	Description
D80L-1002-L	2-Jaw Puller
T87C-7025-C	Differential Plugs
T87C-77000-H	Differential Seal Puller