

# SECTION 07-05 Transaxle, Automatic—External Controls

SUBJECT	PAGE	SUBJECT	PAGE
<b>ADJUSTMENTS</b>		<b>REMOVAL AND INSTALLATION</b>	
Shift Control Cable .....	07-05-12	Gear Selector Assembly .....	07-05-6
<b>DESCRIPTION</b>		Shift Control Cable .....	07-05-5
Transmission Shift Control Linkage.....	07-05-2	Shift-Lock Cable .....	07-05-7
<b>DIAGNOSIS AND TESTING</b>		<b>SPECIFICATIONS</b> .....	07-05-13
System Inspection —Shift-Lock System.....	07-05-3	<b>VEHICLE APPLICATION</b> .....	07-05-1
<b>DISASSEMBLY AND ASSEMBLY</b>			
Gear Selector .....	07-05-9		

## VEHICLE APPLICATION

Capri.

## DESCRIPTION

**Transmission Shift Control Linkage**

The external components required to shift the automatic transaxle are two levers interconnected by an encased cable. At the transaxle, a pin and spring clip attach the shift cable to an external shift lever. At the opposite end, two nuts and a T-joint attach the cable to the gear selector lever. Integral brackets anchor the ends of the protective casing to the transaxle case and to the gear selector housing. An additional routing clamp secures the cable and directs it out of the engine compartment toward the gear selector. Where the cable extends from the casing to one of the levers, protection is provided to prevent the entry of contaminants. At the transaxle a flexible, rubber boot encloses the cable and the end of the cable casing. The hole where the cable enters the gear selector housing is sealed by a rubber grommet installed on the end of the casing.

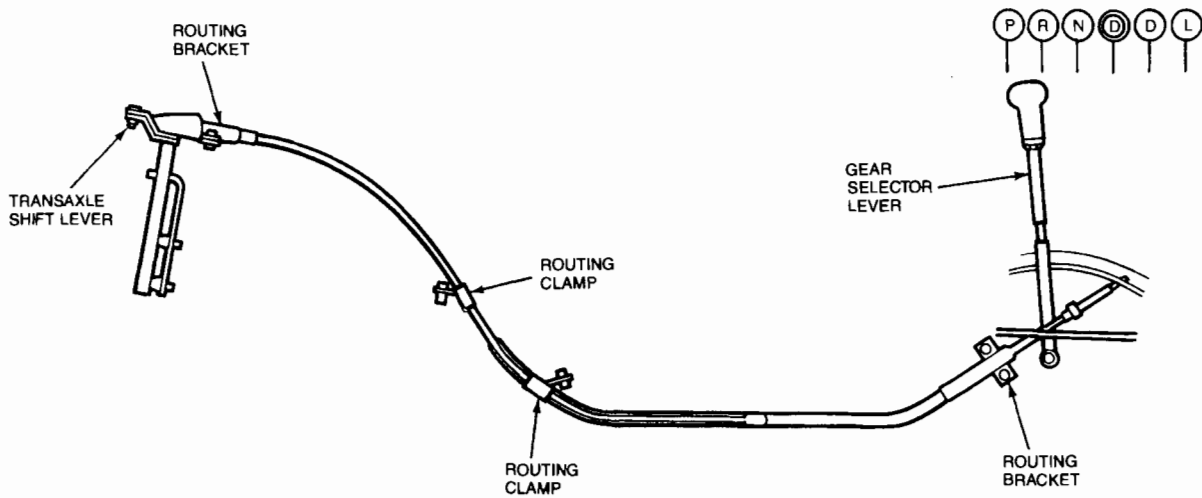

At the gear selector housing, the cable end and T-joint are connected to an intermediate link. The T-joint pin passes through the link and a roller / bushing that rides in a guide plate attached to the selector housing. From the cable connection and guide, the link extends to a pin attached to the gear selector lever.

In the gear selector housing, the gear selector lever is supported on bushings and a pivot pin that extends through the housing and bushings. A lock washer and nut hold the pivot pin in position. As the lever pivots on the pin, a spring and roller assembly detents each selector position.

Free movement into and out of specific gear selector positions is prevented by a shift interlock button on the gear shift lever and a brake-shift interlock connected to the steering column lock assembly. The brake-shift interlock mechanism prevents shifting the transaxle out of the PARK position unless the brake pedal is depressed. The system consists of a solenoid assembly attached to the brake-shift interlock cable assembly, a bracket retaining the solenoid and the necessary wiring. The solenoid is energized when the ignition switch is turned to the RUN position, locking the shifter in the PARK position. When the brake pedal is depressed and the stoplamp switch is activated, the shift lock solenoid is deactivated and the shifter can be moved out of the PARK position.

**DESCRIPTION (Continued)**

The shift lever cannot be moved from P to R,  $\odot$  to D, D to L or N to R unless the button in the shift lever handle is pressed. When the button is pressed, a push rod extending through the gear selector lever pushes downward on the interlock pin. The downward movement of the pin allows it to clear the gates in the interlock plate. A spring, installed below the interlock pin returns the pin, push rod and button to the interlock position when the button is released.

The gear selector housing is installed through the bottom of the floorpan with four stud nuts holding it in position. After removal, the gear selector assembly can be disassembled for inspection and servicing of individual components. The shift cable, however, is serviced only as an assembly. Jam nuts installed on both sides of the cable T-joint allow cable length adjustments.

If the shift lever cannot be pulled from the P (PARK) position with the key on, thumb button pushed and brake pedal depressed, the system can be overridden by pressing the thumb button with increased pressure using both hands.

**System Inspection—Shift-Lock System**

1. Visually inspect the following components of the shift-lock system.

**VISUAL INSPECTION CHART**

Mechanical	Electrical
<ul style="list-style-type: none"> <li>● Gear Selector Lever Out of Adjustment</li> <li>● Shift-Lock Solenoid Does Not Move Freely</li> <li>● Damaged Gear Selector Lever Linkage</li> <li>● Kinked or Bound Shift-Lock Cable</li> <li>● Kinked or Bound Shift Control Cable</li> </ul>	<ul style="list-style-type: none"> <li>● Blown Fuses:                             <ul style="list-style-type: none"> <li>● 30 amp POWER WIND</li> <li>● 15 amp STOP</li> </ul> </li> <li>● Poor Connections</li> <li>● Circuit</li> <li>● Damaged or Disconnected Brake On / Off (BOO) Switch</li> <li>● Damaged Ignition Key Cylinder</li> </ul>

2. Check the wiring harness for obvious signs of shorts, opens, bad connections or damage.
3. If the fault is not visually evident, determine the condition and proceed to the following condition chart.

**DIAGNOSIS AND TESTING**

**Electrical Schematic—Shift-Lock System**

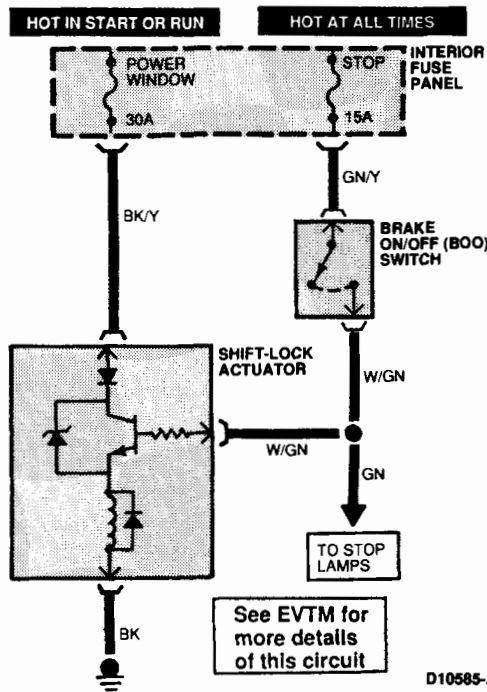

## DIAGNOSIS AND TESTING (Continued)

## CONDITION CHART — SHIFT-LOCK SYSTEM

CONDITION	POSSIBLE SOURCE	ACTION
<ul style="list-style-type: none"> <li>● Gear Selector Lever Stays In Park Range With Key On And Brake Pedal Depressed</li> </ul>	<ul style="list-style-type: none"> <li>● Fuse.</li> <li>● Circuit.</li> <li>● Gear selector lever adjustment.</li> </ul>	<ul style="list-style-type: none"> <li>● Go to A1.</li> <li>● Go to A4.</li> <li>● Refer to adjustments as outlined.</li> </ul>
<ul style="list-style-type: none"> <li>● Gear Selector Lever Can Be Moved With Key On But Without Depressing Brake Pedal</li> </ul>	<ul style="list-style-type: none"> <li>● Brake On/Off (BOO) switch.</li> <li>● Shift-lock solenoid.</li> <li>● Gear selector lever linkage binding.</li> </ul>	<ul style="list-style-type: none"> <li>● Go to A6.</li> <li>● Go to A4.</li> <li>● Inspect for cable freedom, kinking and binding.</li> </ul>
<ul style="list-style-type: none"> <li>● Gear Selector Lever Can Be Moved With Key Off</li> </ul>	<ul style="list-style-type: none"> <li>● Shift-lock solenoid.</li> <li>● Gear selector lever linkage binding.</li> </ul>	<ul style="list-style-type: none"> <li>● Go to A4.</li> <li>● Inspect for cable freedom, kinking and binding.</li> </ul>

## PINPOINT TEST A — SHIFT-LOCK SYSTEM

TEST STEP		RESULT	ACTION TO TAKE
<b>A1</b>	CHECK FUSES		
	<ul style="list-style-type: none"> <li>● Locate interior fuse panel.</li> <li>● Check 30 amp POWER WIND and 15 amp STOP fuse.</li> <li>● Are fuses OK?</li> </ul>	Yes No	► GO to A4. ► GO to A2.
<b>A2</b>	CHECK SYSTEM		
	<ul style="list-style-type: none"> <li>● Replace blown fuse(s).</li> <li>● Key ON.</li> <li>● Does fuse(s) fail again?</li> </ul>	Yes No	► GO to A3. ► GO to A4.
<b>A3</b>	CHECK FOR SHORT(S) TO GROUND		
	<ul style="list-style-type: none"> <li>● Locate and disconnect interior fuse panel connectors.</li> <li>● Locate and disconnect shift-lock actuator and brake on/off (BOO) switch.</li> <li>● Measure resistance between the BK/Y and GN/Y wires at the interior fuse panel connectors and ground.</li> <li>● Is resistance less than 5 ohms?</li> </ul>	Yes No	► SERVICE the wire(s) in question. ► GO to A4.
<b>A4</b>	CHECK POWER SUPPLY TO SHIFT-LOCK ACTUATOR		
	<ul style="list-style-type: none"> <li>● Locate and disconnect shift-lock actuator.</li> <li>● Key ON.</li> <li>● Measure voltage on the BK/Y wire at the shift-lock actuator connector.</li> <li>● Is voltage greater than 10 volts?</li> </ul>	Yes No	► GO to A5. ► SERVICE BK/Y wire.
<b>A5</b>	CHECK POWER SUPPLY TO BRAKE ON/OFF (BOO) SWITCH		
	<ul style="list-style-type: none"> <li>● Locate and disconnect brake on/off (BOO) switch.</li> <li>● Measure voltage on the GN/Y wire at the brake on/off (BOO) switch connector.</li> <li>● Is voltage greater than 10 volts?</li> </ul>	Yes No	► GO to A6. ► SERVICE GN/Y wire.
<b>A6</b>	CHECK BRAKE ON/OFF (BOO) SWITCH		
	<ul style="list-style-type: none"> <li>● Brake On/Off (BOO) switch connected.</li> <li>● Depress brake pedal.</li> <li>● Measure voltage on the W/GN wire at the brake On/Off switch connector.</li> <li>● Is voltage greater than 10 volts?</li> </ul>	Yes No	► GO to A7. ► REPLACE brake on/off (BOO) switch.
<b>A7</b>	CHECK POWER SUPPLY FROM BRAKE ON/OFF SWITCH		
	<ul style="list-style-type: none"> <li>● Disconnect shift-lock actuator.</li> <li>● Depress brake pedal.</li> <li>● Measure voltage on the W/GN wire at the shift-lock actuator connector.</li> <li>● Is voltage greater than 10 volts?</li> </ul>	Yes No	► GO to A8. ► SERVICE W/GN wire.
<b>A8</b>	CHECK SHIFT-LOCK ACTUATOR GROUND		
	<ul style="list-style-type: none"> <li>● Disconnect shift-lock actuator.</li> <li>● Measure resistance between the BK wire at the shift-lock actuator and ground.</li> <li>● Is resistance less than 5 ohms?</li> </ul>	Yes No	► REPLACE shift-lock actuator. ► SERVICE BK wire.

## REMOVAL AND INSTALLATION

## Shift Control Cable

## Disassembled View

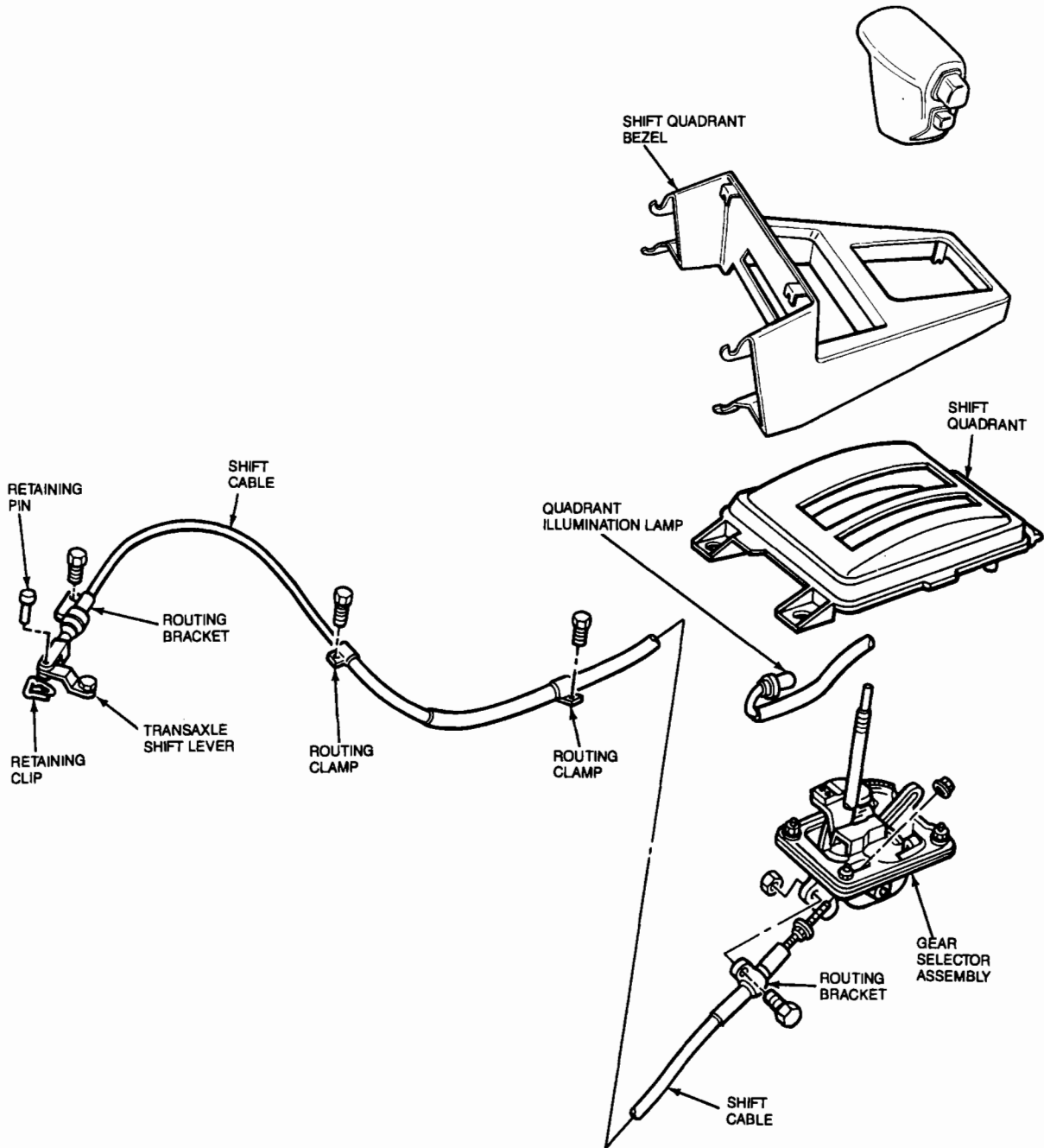

D7269-A

**Removal**

1. Remove the spring clip and pin attaching the transaxle shift cable to the transaxle shift lever.

2. Remove the bolts attaching the cable casing bracket to the transaxle case.

**REMOVAL AND INSTALLATION (Continued)**

3. Remove the shift cable routing clamp retaining bolts. One clamp is located below and to the right of the master cylinder. The other is attached to the subframe.
4. Remove the shift console and quadrant bezel. Refer to Section 01-12.
5. Remove the top adjuster nut from the shift cable.

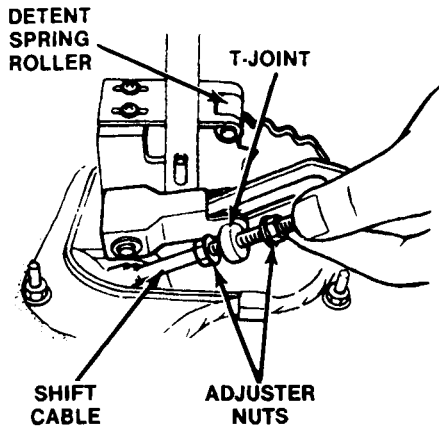

D6865-A

6. Raise the vehicle on a hoist. Refer to Section 00-02.
7. Remove the screws attaching the cable casing bracket to the gear selector housing.
8. Pull the cable out of the gear selector housing and remove from the vehicle.

**Installation**

1. Insert the shift cable into the gear selector housing. Make sure the end of the cable passes through the T-joint as it enters the housing.
2. Install the cable casing bracket to gear selector housing retaining screws. Tighten the retaining screws securely.
3. Install routing clamp and bolt to subframe.
4. Lower the vehicle.
5. Install the cable casing bracket to transaxle case retaining bolts. Tighten the retaining bolt securely.
6. Position the cable and install the routing clamp retaining bolts. Tighten the retaining bolts securely.
7. Install the shift cable adjuster nut.
8. Adjust the shift cable, if necessary, as outlined.
9. Install shift console and quadrant bezel. Refer to Section 01-12.

**Gear Selector Assembly****Removal**

1. Loosen and remove the shift handle and jam nut.
2. Remove the shift interlock pin and push rod.

3. Remove the shift console and quadrant bezel. Refer to Section 01-12.
4. Twist the illumination lamp clockwise and pull it out of the lamp housing.
5. Disengage the lamp wiring from the routing clips on the shift quadrant.
6. Remove the top adjuster nut from the shift cable.

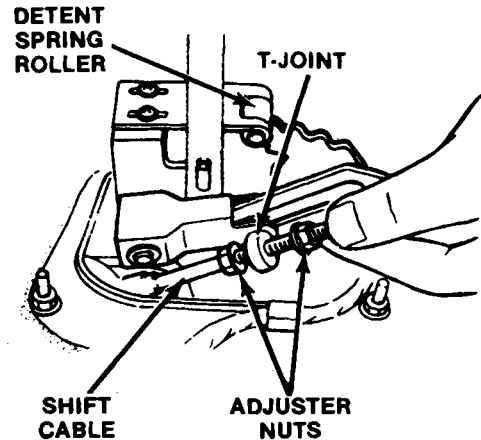

D6865-A

7. Remove the cable casing bracket to gear selector housing retaining screws.
8. Remove the gear selector retaining nuts and the quadrant / console mounting bracket.
9. Bend the gear selector retainer clips back just far enough to clear the floorpan.
10. Raise the vehicle on a hoist. Refer to Section 00-02.
11. Pull the gear selector downward and away from the floorpan. It may be necessary to pry downward slightly on the exhaust system to provide the necessary clearance.
12. Remove the screws attaching the cable casing bracket to the gear selector housing.
13. Pull the shift cable out of the gear selector housing and remove the gear selector.

**Installation**

1. Install the shift cable into the gear selector housing. Make sure the end of the cable passes through the T-joint as it enters the housing.
2. Install the adjuster nut on the end of the shift cable to prevent it from pulling out of the T-joint.
3. Install the cable casing bracket to gear selector housing retaining screws. Tighten the retaining screws securely.
4. Bend the retainer tabs outward so that they will hook on the floorpan when the gear selector is installed.
5. Position the gear selector in the floorpan. If necessary pry downward on the exhaust system to provide the necessary clearance.
6. Lower the vehicle.

**REMOVAL AND INSTALLATION (Continued)**

7. Position the quadrant / console mounting bracket and install the gear selector retaining nuts. Tighten the retaining nuts to 7-10 N-m (62-88 lb-in).
8. Route the lamp wiring through the shift quadrant routing clips. Install lamp housing and lock in position by turning counterclockwise.
9. Position the gear selector on the mounting bracket and install the retaining nuts.
10. Install shift console and quadrant bezel. Refer to Section 01-12.
11. Install the shift interlock pin.
12. Install push rod, jam nut and the shift handle to end of threads. Turn handle until it contacts jam nut. Position interlock button toward driver and tighten jam nut to 15-20 N-m (11-14 lb-ft). Check for proper operation. Adjust jam nut, if required.
13. Adjust the shift cable if necessary, as outlined.

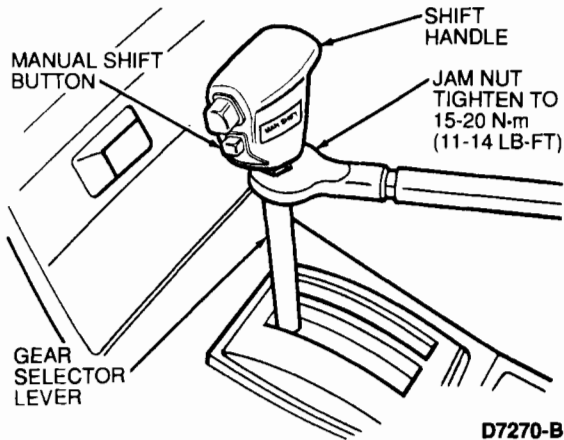

D7270-B

**Shift-Lock Cable**

**Removal and Installation**

**CAUTION: Be certain not to kink shift-lock cable.**

1. Disconnect the negative battery cable.
2. Remove the screws securing the gear selector knob to the gear selector lever. Remove the knob.
3. Remove the shift console. Refer to Section 01-12.
4. Remove 4 screws securing the position indicator.

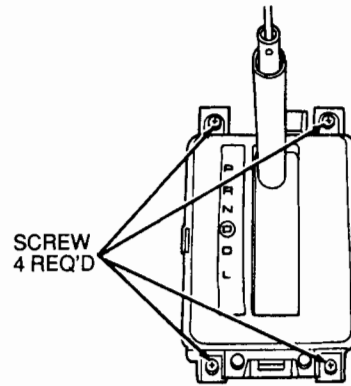

D10665-A

5. Disconnect the illumination bulb from the position indicator.
6. Remove position indicator.
7. Remove shift-lock cable retaining nut at shift lever.

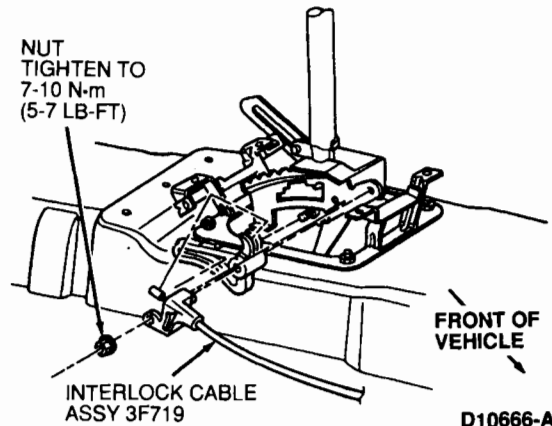

D10666-A

8. Remove speed control amplifier nuts.

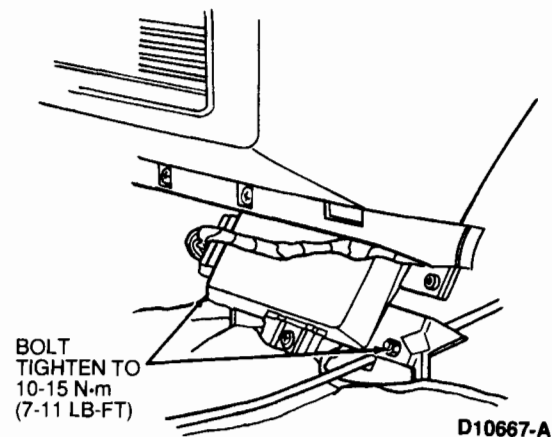

D10667-A

**REMOVAL AND INSTALLATION (Continued)**

9. Remove center trim panel cover under steering column.
10. Remove screws securing the lower steering column trim cover. Remove lower cover.
11. Remove the two steering column bolts and lower steering column.
12. Remove ignition switch. Refer to Section 11-05.
13. Remove steering column upper trim cover.
14. Remove shift-lock cable mounting bolt at steering column.

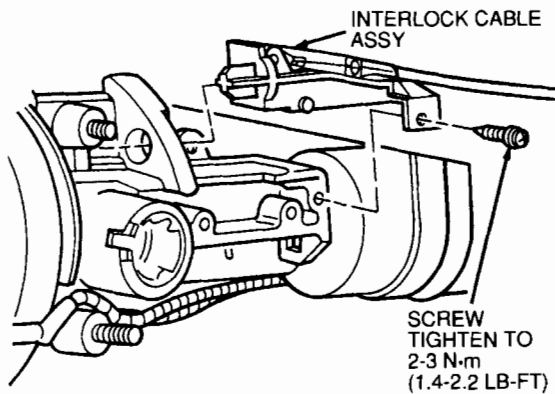

15. Remove shift-lock cable at the steering column.
16. To install, reverse Removal procedure.



### DISASSEMBLY AND ASSEMBLY

#### Gear Selector

#### Disassembled View

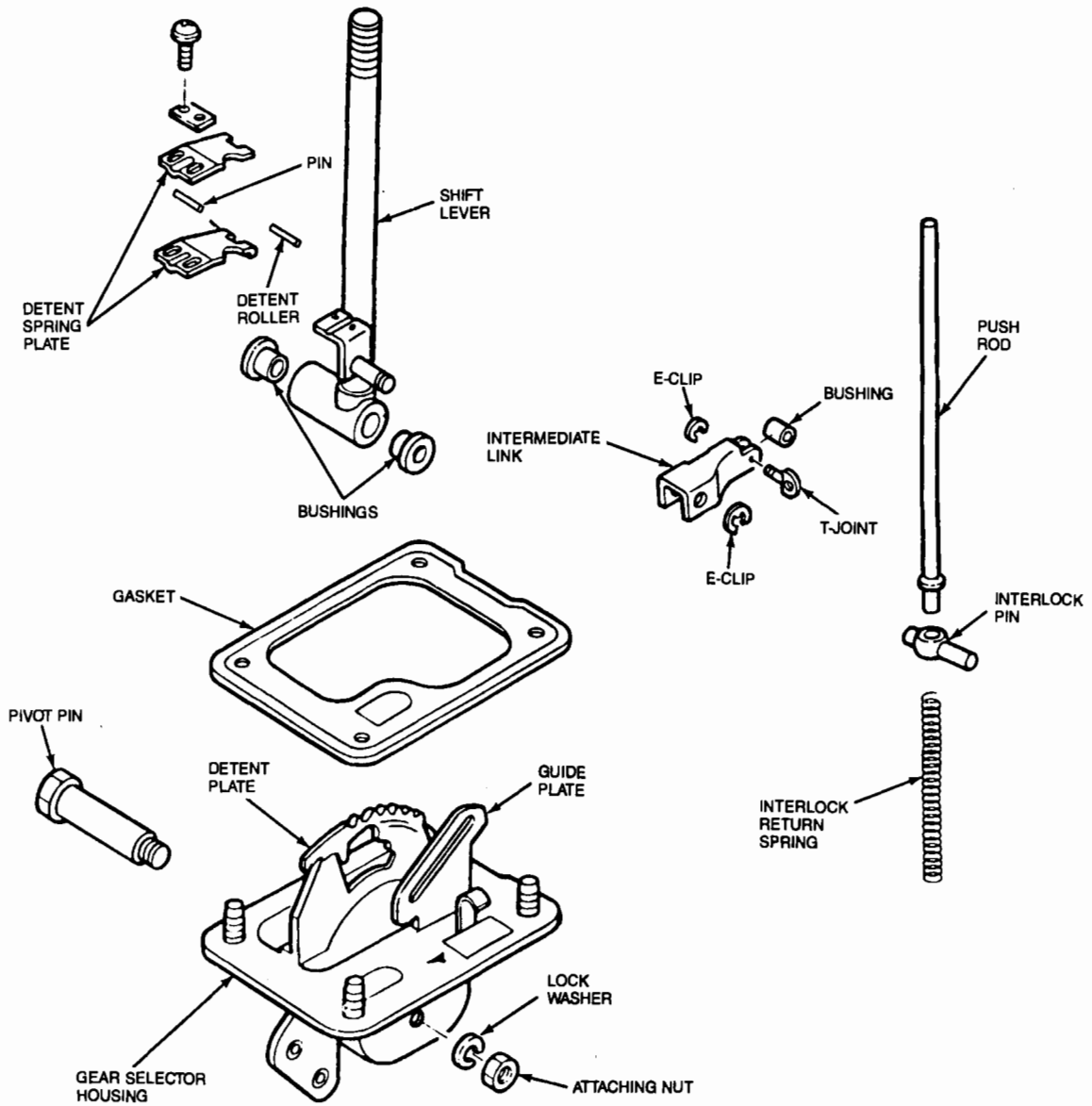

D727-A

**DISASSEMBLY AND ASSEMBLY (Continued)****Disassembly**

1. Remove the E-clip from the T-joint pin.

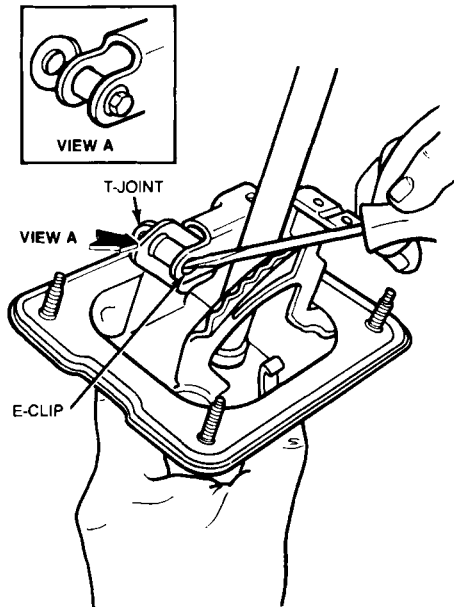

D7337-A

2. Remove the T-Joint and intermediate link bushing. Lift the intermediate link to remove the bushing.

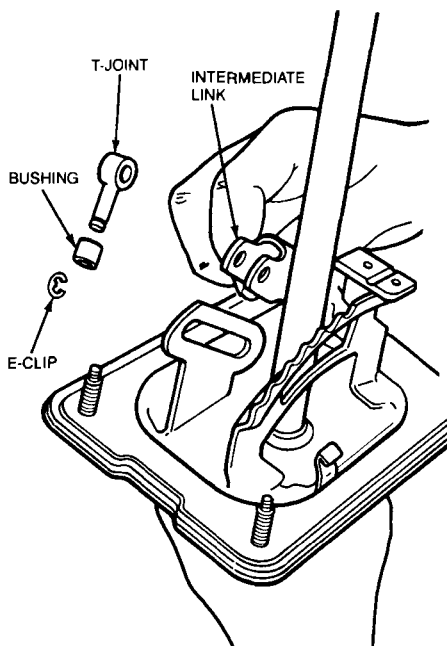

D7338-A

3. Remove the E-clip from the intermediate link pivot pin and remove the link.

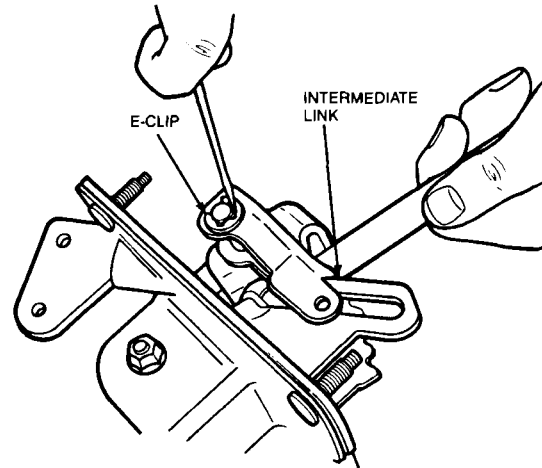

D7336-A

4. Using a small screwdriver turn the interlock pin 90 degrees. The screwdriver slot will move from the vertical position to the horizontal position.

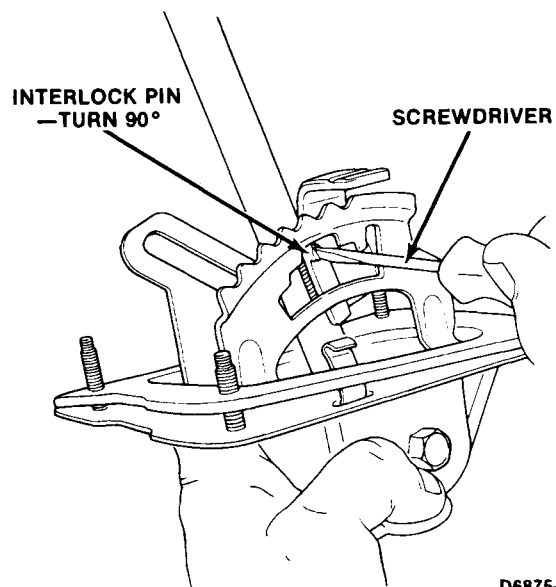

D6875-A

5. Press downward on the interlock pin with the interlock push rod and pull the pin out of the selector lever. The push rod must be used to hold the tensioned spring in position while the interlock pin is removed.
6. Remove the interlock push rod and return spring.

**DISASSEMBLY AND ASSEMBLY (Continued)**

7. Remove the detent spring and roller assembly.

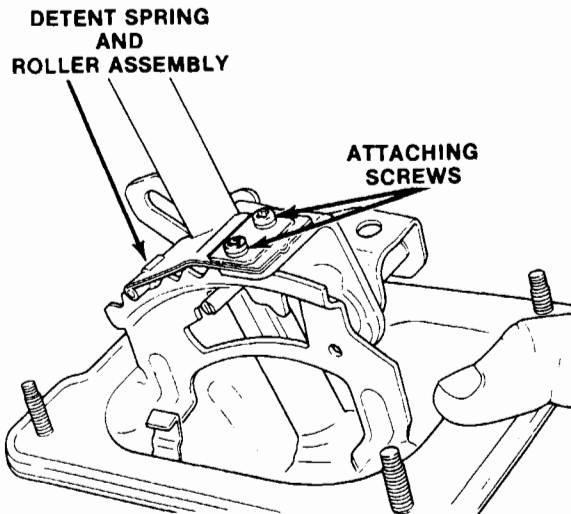

D6878-A

8. Remove the shift lever retaining nut, lock washer and pivot pin.

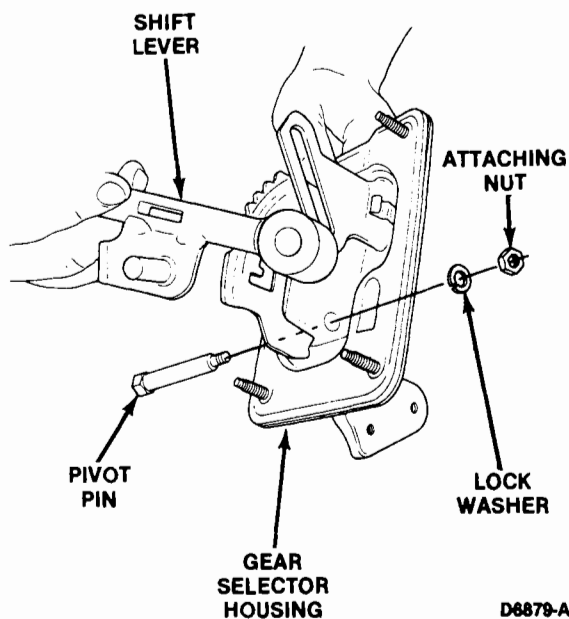

D6879-A

9. Remove the shift lever from the gear selector housing.  
10. Remove the bushings from the shift lever.

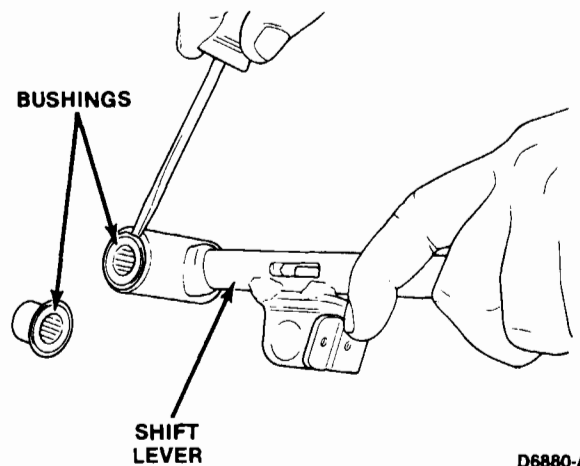

D6880-A

11. Remove gasket from the gear selector housing.

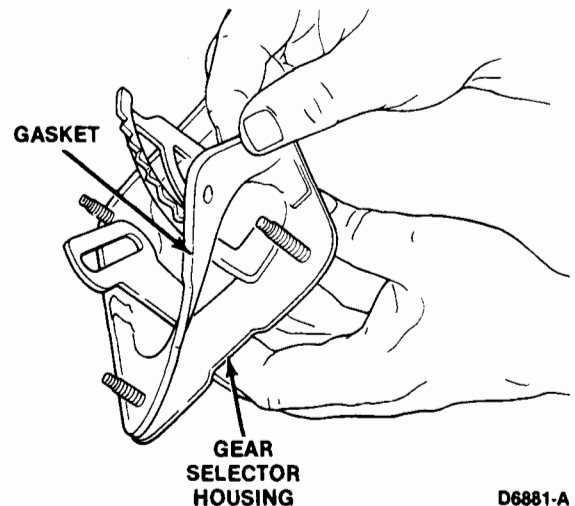

D6881-A

**Assembly**

1. Install the gear selector housing gasket.
2. Install the shift lever bushings.
3. Position the shift lever in the housing.
4. Install the shift lever pivot pin.
5. Install the pivot pin attaching lock washer and nut. Tighten the retaining nut to 12-17 N·m (9-12 lb-ft).
6. Install the shift interlock return spring and push rod.
7. Compress the interlock return spring using a thin-bladed screwdriver. While holding the spring compressed, insert the interlock pin through the shift lever and turn 90 degrees. Make sure the slot in the pin is in the vertical position and remove the screwdriver.  
**NOTE:** When properly installed, the interlock pin should extend through the interlock plate and the interlock push rod should engage the hole in the pin.
8. Install the intermediate link on the pivot pin and install the E-clip.

**DISASSEMBLY AND ASSEMBLY (Continued)**

9. Install the intermediate link bushing and T-joint.
10. Install the E-clip on the T-joint pin.
11. Install the detent spring. Position the shift lever in the park position, make sure the detent spring roller is centered in the park detent and tighten the retaining screws.

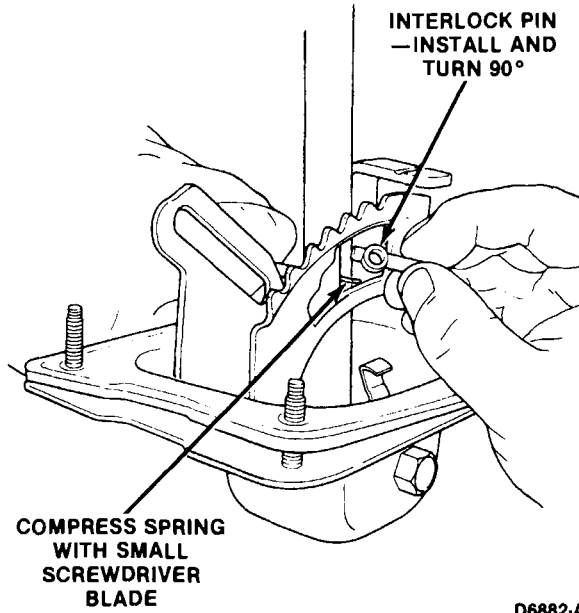

D6882-A

**ADJUSTMENTS****Shift Control Cable**

1. Position the gear selector lever in the NEUTRAL position.
2. Remove the spring clip and pin attaching the shift cable trunnion to the transaxle shift lever.
3. Rotate the transaxle shift lever fully counterclockwise. This is the park position.
4. Rotate the transaxle shift lever clockwise two detents. This is the NEUTRAL position. As the lever is rotated, position it between the ends of the shift cable trunnion.

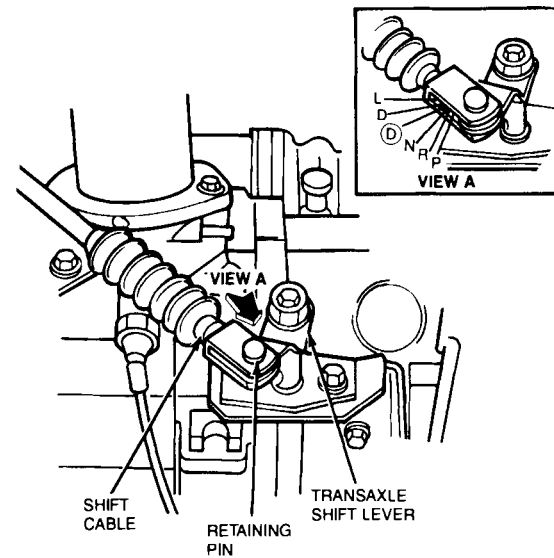

D7343-A

5. If the holes in the shift lever align with the holes in the trunnion, the cable is properly adjusted. If the holes do not align proceed to the next step.
6. Remove console shift quadrant. Refer to Section 01-12.
7. Loosen the adjuster nuts on the shift cable.

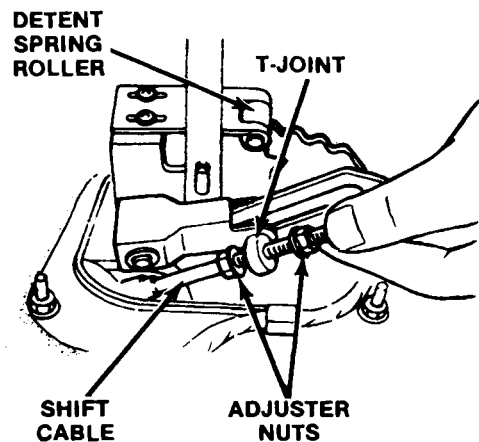

D6865-A

8. Position the gear selector lever in the PARK position and inspect the position of the detent spring roller.  
If the spring roller is centered in the park detent, proceed to Step 13.  
If the spring roller is not centered in the park detent, proceed to the next step.
9. Loosen the retaining screws and move the detent spring forward or backward to center it in the park detent.
10. Position the quadrant and install the retaining screws.

## ADJUSTMENTS (Continued)

11. Position the selector lever in the NEUTRAL position.
12. Thread the adjuster nuts up or down the cable until the holes in the transaxle shift lever and the shift cable trunnion are aligned.

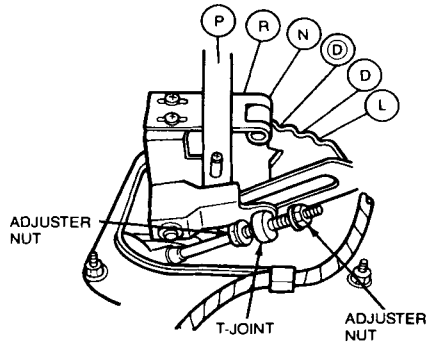

NOTE: SHIFT QUADRANT IS SHOWN REMOVED FOR CLARITY

D7344-A

13. Tighten the adjuster nut to 8-11 N-m (7.1-9.7 lb-in).
14. Check the alignment of the holes in the transaxle shift lever and cable trunnion to make sure the adjustment was not disturbed while tightening the nuts.
15. Install the transaxle shift lever to shift cable attaching pin and retaining clip.
16. With the gear selector lever in the NEUTRAL position, press in on the shift interlock button and carefully push the lever forward while an assistant observes the transaxle shift lever. When the transaxle shift lever begins to move, note the amount the shift lever has moved.
17. With the gear selector lever in the NEUTRAL position, press in on the shift interlock button and carefully pull the lever rearward while an assistant observes the transaxle shift lever. When the transaxle lever begins to move, note the amount the shift lever has moved.
18. If the forward movement of the shift lever (a) and the rearward movement of the gear selector lever (b) are not equal, turn the adjuster nuts a slight amount until they become equal.

If (a) is larger than (b), loosen locknut (B) and tighten locknut (A) so that (a) becomes smaller.

If (b) is larger than (a), loosen locknut (A) and tighten locknut (B) so that (b) becomes smaller.

19. Tighten the adjuster nut to 8-11 N-m (7.1-9.7 lb-in).

**WARNING: MAKE SURE THE LINKAGE ADJUSTMENT HAS NOT AFFECTED OPERATION OF THE NEUTRAL SAFETY SWITCH. WITH THE PARKING BRAKE AND SERVICE BRAKES APPLIED, TRY TO START THE ENGINE IN EACH GEARSHIFT POSITION. THE ENGINE MUST CRANK ONLY IN THE NEUTRAL AND PARK POSITIONS. IF THE ENGINE CRANKS IN ANY OF THE OTHER GEAR SELECTOR LEVER POSITIONS, CHECK THE LINKAGE ADJUSTMENT AND NEUTRAL SAFETY SWITCH OPERATION.**

20. Position the console and install the retaining screws. Refer to Section 01-12.

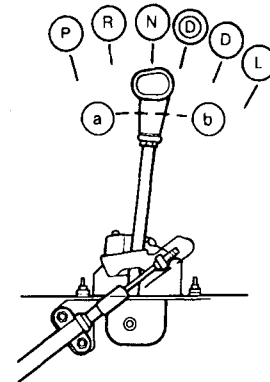

D7345-A

## SPECIFICATIONS

## TORQUE SPECIFICATIONS

Description	N-m	Lb-Ft
Adjuster Nut	8-11	7.1-9.7 (Lb-In)
Gear Selector Nuts	7-10	62-88 (Lb-In)
Shift Handle Jam Nut	15-20	11-14
Selector Lever Pivot Pin Nut	12-17	9-12
Interlock Cable at Shifter	7-10	5-7
Interlock Cable at Steering Column	2-3	1.4-2.2